

**mitsubishi
electric**

INVERTER

Model

FR-A700



Changes for the Better

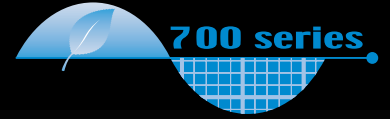

Highest level in your hand



MITSUBISHI
FREQROL-A700

Mitsubishi Electric Corporation Nagoya Works is a factory certified for ISO14001 (standards for environmental management systems) and ISO9001 (standards for quality assurance management systems)



FR-A700

Mitsubishi real sensorless vector control ensures the highest level of driving performance

Highest level in your hand



Highest level of driving performance

Advanced driving performance makes it possible to support a wide range of applications from variable-speed applications such as conveyance and chemical machines to line control applications such as winding machines and printing machines.



Long life parts and life check function

Adoption of long life parts ensures more reliable operation. The reliable life diagnosis function notifies the maintenance time.



Network connection as you desired

It is compatible with CC-Link communication, SSCNET and other major overseas networks. The inverter can be controlled or monitored via network from the controller.



Environmental consciousness

Noise measures are available without an option. Harmonic currents technique is available with a new type reactor.



• Features	3
• Connection with Peripheral Devices	8
• Standard Specifications	9
• Outline Dimension Drawings	11
• Terminal Connection Diagram	22
• Terminal Specification Explanation	22
• Explanation of the Operation Panel	27
• Parameter List	29
• Explanations of Parameters	42
• Protective Functions	75
• Option and Peripheral Devices	77
• Precautions for Operation/Selection	89
• Precautions for Peripheral Device Selection	89
• Application to Motor	93
• Main Differences and Compatibilities with the FR-A500(L) Series	104
• Warranty	105
• Service	106
• International FA Center	106

Highest Level of Driving Performance



(1) Exhibit best performance of the general-purpose motor (real sensorless vector control)

High accuracy/fast response speed operation by the vector control can be performed with a general-purpose motor without encoder.

- Maximum of **200%** high torque can be generated at an ultra low speed of **0.3Hz** (0.4K to 3.7K).
- Torque control operation can be performed also.* (Torque control range 1:20, absolute torque accuracy $\pm 20\%$, repeated torque accuracy $\pm 10\%$)

* Since torque control can not be performed in the low speed regeneration region and at a low speed with light load, use the vector control with encoder.

- Response level has been improved.

Speed control range 1:200 (0.3Hz to 60Hz driving only)

Speed response 120rad/s

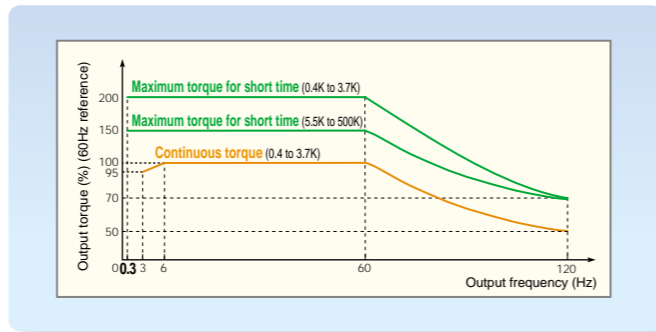

Example of torque characteristic under real sensorless vector control
When the motor SF-JR 4P is used (at 220V input)

1. Torque limit function limits the maximum motor torque during speed control

Torque limit function is effective to prevent machine from damage (prevention against damage of grinding machine tools, etc.) against the sudden disturbance torque.

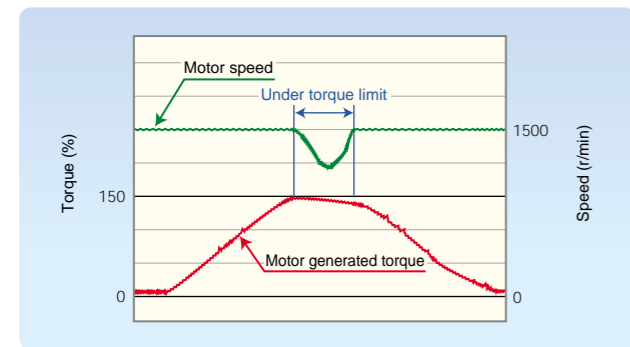

Example of torque limit characteristic
When the motor SF-JR 4P 3.7kW is used

2. Improvement of input command signal response

The delay to the input command has been minimized. The response time has been reduced to half as compared to the conventional model (FR-A500). It is suitable for cycle-operation applications.

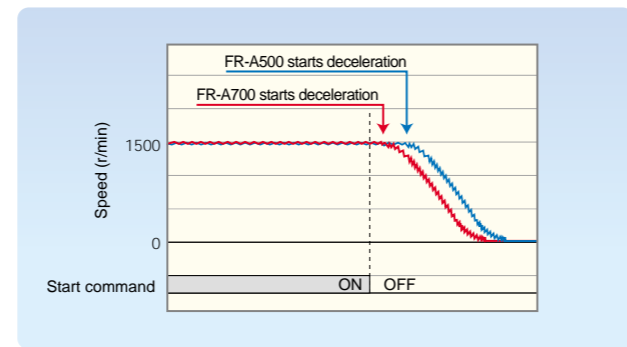

Example of input command signal response characteristic

3. Quick response to the sudden load fluctuation

Torque response level to the sudden load fluctuation has been greatly improved as compared to the conventional model (FR-A500). The motor speed variation is minimized to maintain a constant speed. It is suitable for a sawmill machine, etc.

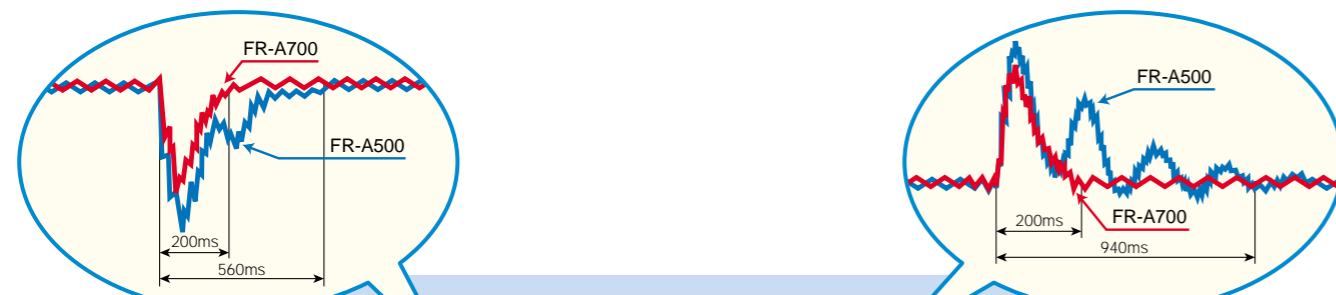

The actual motor speed decelerates instantly at the moment when the load torque increases and then it immediately returns to the set speed.

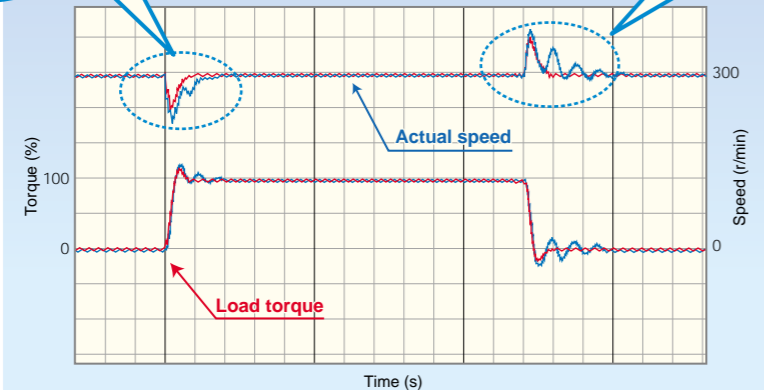

Example of actual speed variation when a load is instantaneously applied
FR-A700 series under real sensorless vector control
FR-A500 series under advanced magnetic flux vector control

The actual motor speed increases instantly at the moment when the load torque decreases and then it immediately returns to the set speed.

(2) Higher accuracy operation is realized with a motor with encoder (vector control)



Vector control operation can be performed using a motor with encoder*1. Torque control/position control*2 as well as fast response/high accuracy speed control (zero speed control, servo lock) can be realized with the inverter.

*1 A plug-in option for encoder feed back control (FR-A7AP) is necessary.

*2 Only a pulse train+code system is employed for pulse command system when performing position control with an inverter and the FR-A7AP.

The maximum pulse input is 100kpps.

• Speed control

Speed control range 1:1500 (both driving/regeneration*3)

Speed variation rate $\pm 0.01\%$ (100% means 3000r/min)

Speed response 300rad/s (with model adaptive speed control)

*3 Regeneration unit (option) is necessary for regeneration

• Torque control

Torque control range 1:50

Absolute torque accuracy $\pm 10\%$ *4

Repeated torque accuracy $\pm 5\%$ *4

*4 Online auto tuning (with adaptive magnetic flux observer)

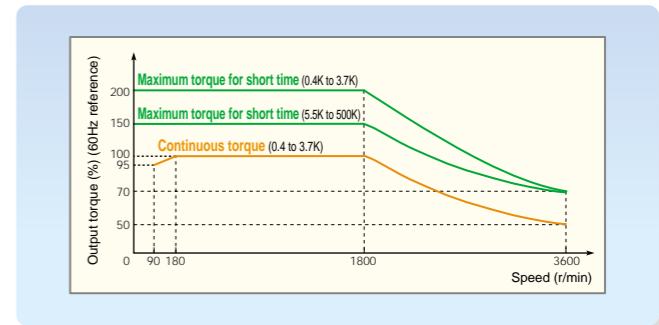

Example of torque characteristic under vector control
When the motor with encoder, SF-JR4P, is used (at 220V input)

1. Easy gain tuning

Since the load inertia of the motor is automatically estimated online to calculate the optimum speed control gain and position loop gain, gain adjustment is easily done. By repeating acceleration and deceleration, load inertia is automatically estimated.

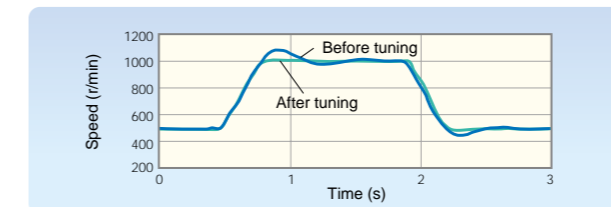

Comparison of the speed accuracy before and after the load inertia estimation

2. High accuracy torque control with online auto tuning

Operation with high torque accuracy less susceptible to the motor second resistance value change due to a temperature change is realized with online tuning (adaptive magnetic flux observer). This operation is appropriate for applications such as a winder/printing machine (tension control) which is controlled by torque.

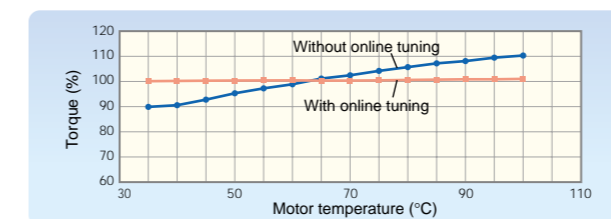

Example of motor temperature-torque characteristics

3. Vector control dedicated motor

Use of vector control dedicated motor realizes 100% of the continuous operation torque even at a low speed. It is suitable for winder and unwinder applications. Motors with speed ratio of 1000/2000r/min, 1000/3000r/min and 500/2000r/min specifications are available and they can support applications whose winding diameter greatly changes. Decreasing the rated speed will increase the rated torque, so you can select a motor with a smaller capacity. (The inverter one or two rank higher than the motor in capacity needs to be selected depending on the motor capacity.)

• Lineup of vector control dedicated motors

Type	Base/Maximum Speed (r/min)	Motor Capacity
SF-V5RU	1500/3000	1.5kW to 55kW
SF-V5RU□1	1000/2000	1.5kW to 37kW
SF-V5RU□3	1000/3000	1.5kW to 30kW
SF-V5RU□4	500/2000	1.5kW to 15kW
SF-THY	1500/3000	75kW to 250kW



Vector control dedicated motor
SF-V5RU-1.5K

(3) V/F control and advanced magnetic flux vector control operations are also available



Since V/F control and advanced magnetic flux vector control operations are also available, you can replace the conventional model (FR-A500 series) without anxiety.

• Complement: list of functions according to driving control method

Control Method	Speed Control	Torque Control	Position Control	Speed Control Range	Speed Response	Applied Motor
V/F	○	×	×	1:10 (6 to 60Hz : Driving)	10 to 20rad/s	General-purpose motor (without encoder)
Advanced magnetic flux vector	○	×	×	1:120 (0.5~60Hz : Driving)	20 to 30rad/s	General-purpose motor (without encoder)
Real sensorless vector	○	○	×	1:200 (0.3~60Hz : Driving)	120rad/s	General-purpose motor (without encoder)
Vector (FR-A7AP is necessary)	○	○	○*5	1:1500 (1~1500r/min: Both driving/regeneration)*6	300rad/s	General-purpose motor (with encoder) Dedicated motor

*5 Only a pulse train+code method is employed for pulse command method when performing position control with an inverter and the FR-A7AP. The maximum pulse input is 100kpps.

*6 Regeneration unit (option) is necessary for regeneration

2 Long Life Components and Life Check Function



(1) Further extended components life

- The life of a newly developed cooling fan has been extended to 10 years of design life*1. The life of the cooling fan is further extended with ON/OFF control of the cooling fan.
- Longevity of capacitor was achieved with the adoption of a design life of 10 years*1*2.
(A capacitor with specification of 5000 hours at 105 °C ambient temperature is adapted.)

*1 Ambient temperature : annual average 40°C (free from corrosive gas, flammable gas, oil mist, dust and dirt).
Since the design life is a calculated value, it is not a guaranteed value.
*2 Output current: equivalent to rating current of the Mitsubishi standard motor (4 poles).

• Life indication of life components

Components	Life Guideline of the FR-A700	Guideline of JEMA*3
Cooling fan	10 years	2 to 3 years
Main circuit smoothing capacitor	10 years	5 years
Printed board smoothing capacitor	10 years	5 years

*3 Excerpts from "Periodic check of the transistorized inverter" of JEMA (Japan Electrical Manufacturer's Association).

(2) State of the art longevity diagnostic method

- Degrees of deterioration of main circuit capacitor, control circuit capacitor or inrush current limit circuit can be monitored.
- Since a parts life alarm can be output*4 by self-diagnosis, troubles can be avoided.

*4 Any one of main circuit capacitor, control circuit capacitor, inrush current limit circuit and cooling fan reaches the output level, an alarm is output.
For the main circuit capacitor, the capacitor capacity needs to be measured during a stop by setting parameter.

3 Network Connection as You Desired



(1) Compatible with the CC-Link communication (option)

The inverter can be connected to the Mitsubishi Programmable controller (Q, QnA, A series, etc.) through the CC-Link. It is compatible with the CC-Link Ver.1.1 and Ver.2.0. The inverter operation, monitoring and parameter setting change can be done from the Programmable controller.

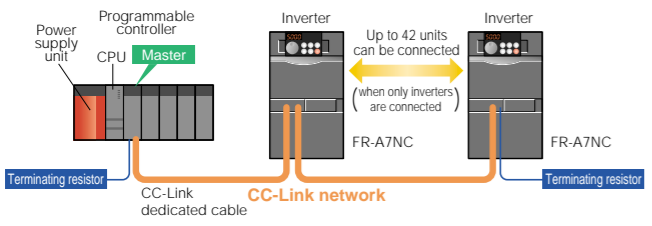

(2) Compatible with SSCNETIII (option, available soon)

The inverter can be connected to Mitsubishi motion controller through the SSCNETIII. The SSCNETIII employs a high-speed synchronous serial communication system and is appropriate for the synchronous operation.

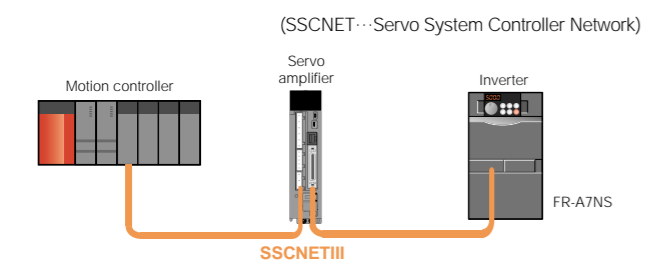

(3) RS-485 and USB connection

- The RS-485 terminals are equipped as standard in addition to the PU connector. You can make RS-485 communication with the operation panel or parameter unit connected to the PU connector.
- Since the inverter can be connected to the network with terminals, multi-drop connection is also easily done.
- Modbus-RTU (Binary) protocol has been added for communications in addition to the conventional Mitsubishi inverter protocol (computer link).
- As a USB connector (USB1.1B connector) is standard equipped, communication with a personnel computer can be made with a USB cable only.
- Using the RS-485 terminal or USB connector, you can make communication by the FR Configurator (setup SW).

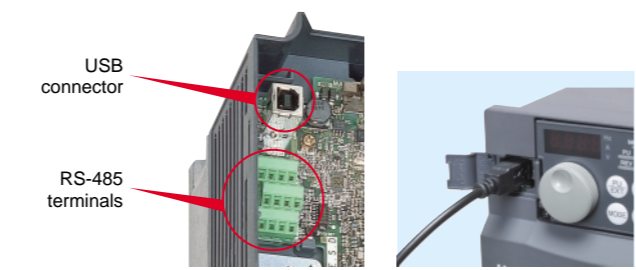

(4) Corresponds to major networks overseas

The inverter can be connected with networks such as Device-NET™, PROFIBUS-DP, LonWorks, EtherNet and CANopen when communication options are used.

LonWorks is a registered trademark of Echelon Corporation and DeviceNet is of ODVA. Other company and product names herein are the trademarks of their respective owners.

4 Free of Environmental Worries



(1) Reduction of electromagnetic noise (built-in EMC filter)

- Reduction of noise generated from the inverter was achieved with adoption of a new technology (low-noise of switching power, low noise of inverter element).
- Because of the newly developed built-in noise filter (EMC filter), the inverter itself can comply with the EMC Directive (2nd Environment*3). (To make the EMC filter of the inverter valid*1, set ON/OFF connector*2 to ON.)

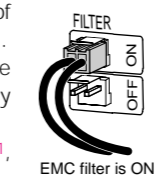

*1 Leakage current will increase when the EMC filter is selected.
*2 The EMC filter is factory-set to disable (OFF). Since the leakage current when using the EMC filter for the 200V class 0.4K and 0.75K is small, the filter is always valid (setting connector is not provided). The input side zero-phase reactor, built-in the 55K or less inverter, is always valid regardless of on/off of the EMC filter on/off connector.
*3 Refer to the EMC installation manual for compliance conditions.

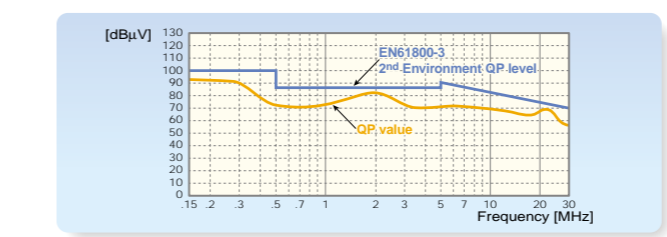

	Capacitive Filter (Radio noise filter)	Zero-phase Reactor (Line noise filter)	DC Reactor
55K or less	Standard (built-in)	Standard (built-in)	Option (sell separately)
75K or more	Standard (built-in)	Option (sell separately)	Standard (provided)

(2) Measures against harmonic leakage current

- A compact AC reactor (FR-HAL) and a DC reactor (FR-HEL), which limit harmonics current flowing into the power supply and improve the power factor, are available as options. (For the 75K or more, a DC reactor is supplied as standard.)



- A high power factor converter (FR-HC, MT-HC) for effective suppressions of power-supply harmonics (conversion coefficient: K5=0) can be connected.

(3) Equipped with inrush current suppression circuit

Because of the built-in inrush current limit circuit, the current at power on can be restricted.

5 Simple Operation and Easy Maintenance



(1) Easy maintenance with FR Configurator (Option)

- Parameter management (parameter setting, file storage, printing) is easy.
- Maintenance and setup of the inverter can be done from a personal computer connected with USB.
- Mechanical resonance is easily avoided with machine analyzer function.
- Parameter setting after replacement of the FR-A500 series can be made with a parameter automatic conversion function.



(3) New type parameter unit FR-PU07 (option)

- An operation panel can be removed and a parameter unit can be connected.
- Setting such as direct input method with a numeric keypad, operation status indication, and help function are usable. Eight languages can be displayed.
- Parameter setting values of a maximum of three inverters can be stored.
- Since a battery pack type (available soon) is connectable, parameter setting and parameter copy can be performed without powering on the inverter.



(2) Operation panel with the popular setting dial

- Possible to copy parameters with operation panel. Parameter setting values are stored in the operation panel and optional parameter unit (FR-PU07).
- Operation is easy with the setting dial.



(4) Easy replacement with the cooling fan cassette

Cooling fans are provided on top of the inverter. Cooling fans can be replaced without disconnecting main circuit wires.



(5) Removable terminal block

A removable terminal block was adapted. (The terminal block of the FR-A700 series is compatible with that of the FR-A500 series. Note that some functions of the FR-A700 series are restricted when using the terminal block of the FR-A500 series. Note that the wiring cover is not compatible.)



(6) Combed shaped wiring cover

Since a wiring cover can be mounted after wiring, wiring work is easily done.

- Features
- Peripheral Devices
- Standard Specifications
- Outline Dimension Drawings
- Terminal Connection Diagram Terminal Specification Explanation
- Operation Panel
- Parameter List
- Explanations of Parameters
- Protective Functions
- Option
- Instructions
- Motor
- Compatibility
- Warranty
- Inquiry

6 Improved Usability with Full of Useful Functions

(1) More advanced auto tuning

Tuning accuracy equivalent to that of the conventional tuning of "with rotation mode" is realized with the auto tuning without motor running. Even for the machine which disallows a motor to run during tuning, the motor performance can be maximized. The sophisticated auto tuning function which measures circuit constants of the motor allows sensorless vector control with any kind of motor.

(2) Power-failure deceleration stop function/original operation continuation at instantaneous power-failure

- The motor can be decelerated to a stop when a power failure or undervoltage occurred to prevent the motor from coasting. For fail-safe of machine tool, etc., it is effective to stop the motor when a power failure has occurred.

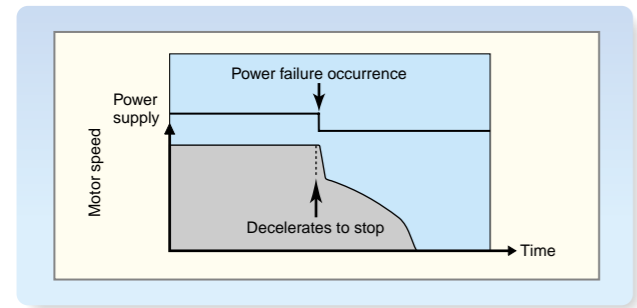

- Since the original operation continuation at instantaneous power failure function has been newly adopted, the motor continues running without coasting even if an instantaneous power failure occurs during operation.

* The inverter may trip and the motor may coast depending on the load condition.

(3) Regeneration avoidance function

For operations of such as a pressing machine, in which an instantaneous regeneration occurs, overvoltage trip can be made less likely to occur by increasing frequency during regeneration.

(4) Built-in brake transistor (22K or less) (0.4K to 7.5K built-in brake resistor)

In addition to the 0.4K to 7.5K, a brake transistor is built-in to the 11K, 15K, 18.5K and 22K. A brake resistor (option) can be also connected to the 11K to 22K.

(5) Pulse train I/O function

Speed command by pulse train signal (single pulse) from the controller etc. can be directly input to the inverter. Since pulse can be output from the inverter at the same time, synchronous speed operation of inverters can be performed. (maximum pulse input 100kpps, output 50kpps)

(6) Enhanced I/O function

- For the analog input terminal (two points), you can switch between voltage (0 to 5V, 0 to 10V) and current (0 to 20mA).
- You can display the ON/OFF status of the I/O terminals on the operation panel.
- Two points relay output is available.

7 Global Compliance

(1) Complies with UL, cUL, EN (Low Voltage Directive) as standard

(2) Sink/source logic can be switched with a single touch

(3) Wide voltage range

Compliance with both 240V power supply (55K or less) and 480V power supply as standard.

Wide range of lineup

FR-A720-0.4K

Symbol	Voltage	Symbol	Inverter Capacity
2	200V class	0.4K-500K	Indicate capacity (kW)
4	400V class		

Applied Motor (kW)	0.4	0.75	1.5	2.2	3.7	5.5	7.5	11	15	18.5	22	30	37	45	55	75	90	110	132	160	185	220	250	280	315	355	400	450	500
Three-phase 200V class FR-A720-□□	●	●	●	●	●	●	●	●	●	●	●	●	●	●	●	●	●	●	●	●	●	●	●	●	●	●	●	●	●
Three-phase 400V class FR-A740-□□	●	●	●	●	●	●	●	●	●	●	●	●	●	●	●	●	●	●	●	●	●	●	●	●	●	●	●	●	●

●: Available models —: Not available

Connection with Peripheral Devices

Three-phase AC power supply
Use within the permissible power supply specifications of the inverter.

Moulded case circuit breaker (MCCB) or earth leakage breaker (ELB), fuse
The breaker must be selected carefully since an in-rush current flows in the inverter at power on.

Magnetic contactor (MC)
Install the magnetic contactor to ensure safety. Do not use this magnetic contactor to start and stop the inverter. Doing so will cause the inverter life to be shorten.

Reactor (FR-HAL, FR-HEL option)
Reactors (option) must be used when power harmonics measures are taken, the power factor is to be improved or the inverter is installed near a large power supply system (1000kVA or more). The inverter may be damaged if you do not use reactors. Select the reactor according to the model. Remove the jumpers across terminals P-P1 to connect the DC reactor to the 55K or less.

AC reactor (FR-HAL)

DC reactor (FR-HEL)
For the 75K or more, a DC reactor is supplied. Always install the reactor.

Noise filter (FR-BLF)
The 55K or less has a built-in zero-phase reactor.

Noise filter (FR-BSF01, FR-BLF)
Install a noise filter to reduce the electromagnetic noise generated from the inverter. Effective in the range from about 1MHz to 10MHz. A wire should be wound four turns at a maximum.

High-duty brake resistor (FR-ABR*)
Braking capability of the inverter built-in brake can be improved. Remove the jumper across terminal PR-PX when connecting the high-duty brake resistor. (7.5K or less)
*3 Compatible with the 22K or less.

USB connector
A personal computer and an inverter can be connected with a USB (Ver1. 1) cable.

High power factor converter (FR-HC*1, MT-HC*2)
Power supply harmonics can be greatly suppressed. Install this as required.

Power regeneration common converter (FR-CV*1)
Power regeneration converter (MT-RC*2) Great braking capability is obtained. Install this as required.

Resistor unit (FR-BR*1, MT-BR5*2)
The regenerative braking capability of the inverter can be exhibited fully. Install this as required.

Brake unit (FR-BU*1, MT-BU5*2)

Devices connected to the output
Do not install a power factor correction capacitor, surge suppressor or radio noise filter on the output side of the inverter. When installing a moulded case circuit breaker on the output side of the inverter, contact each manufacturer for selection of the moulded case circuit breaker.

Earth (Ground)
To prevent an electric shock, always earth (ground) the motor and inverter. For reduction of induction noise from the power line of the inverter, it is recommended to wire the earth (ground) cable by returning it to the earth (ground) terminal of the inverter.

- Features
- Peripheral Devices
- Standard Specifications
- Outline Dimension Drawings
- Termination Diagram Terminal Specification Explanation
- Operation Panel
- Parameter List
- Explanation of Parameters
- Protective Functions
- Option
- Instructions
- Motor
- Compatibility
- Warranty
- Inquiry

Standard Specifications

Rating

●200V class

Type FR-A720-□□K		0.4	0.75	1.5	2.2	3.7	5.5	7.5	11	15	18.5	22	30	37	45	55	75	90	
Applicable motor capacity (kW) *1		0.4	0.75	1.5	2.2	3.7	5.5	7.5	11	15	18.5	22	30	37	45	55	75	90	
Rated capacity (kVA) *2		1.1	1.9	3.1	4.2	6.7	9.2	12.6	17.6	23.3	29	34	44	55	67	82	110	132	
Rated current (A) *3		3	5	8	11	17.5	24	33	46	61	76	90	115	145	175	215	288 (245)	346 (294)	
Overload current rating *4		150% 60s, 200% 3s (inverse time characteristics) ambient temperature 50°C																	
Voltage *5		Three-phase 200 to 240V																	
Regenerative braking torque		150% torque/ 3%ED			100% torque/ 3%ED			100% torque/ 2%ED			20% torque/ continuous *5			20% torque/ continuous			10% torque/ continuous		
Rated input AC voltage/frequency		Three-phase 200 to 220V 50Hz, 200 to 240V 60Hz																	
Permissible AC voltage fluctuation		170 to 242V 50Hz, 170 to 264V 60Hz																	
Permissible frequency fluctuation		±5%																	
Power supply capacity (kVA) *7		1.5	2.5	4.5	5.5	9	12	17	20	28	34	41	52	66	80	100	110	132	
Protective structure (JEM 1030) *9		Enclosed type (IP20) *8											Open type (IP00)						
Cooling system		Self-cooling			Forced air cooling														
Approx. mass (kg)		1.9	2.3	3.8	3.8	3.8	7.1	7.1	7.5	13	13	14	23	35	35	58	70	70	

●400V class

Type FR-A740-□□K		0.4	0.75	1.5	2.2	3.7	5.5	7.5	11	15	18.5	22	30	37	45	55
Applicable motor capacity (kW) *1		0.4	0.75	1.5	2.2	3.7	5.5	7.5	11	15	18.5	22	30	37	45	55
Rated capacity (kVA) *2		1.1	1.9	3	4.6	6.9	9.1	13	17.5	23.6	29	32.8	43.4	54	65	84
Rated current (A)		1.5	2.5	4	6	9	12	17	23	31	38	44	57	71	86	110
Overload current rating *4		150% 60s, 200% 3s (inverse time characteristics) ambient temperature 50°C														
Voltage *5		Three-phase 380 to 480V														
Regenerative braking torque		100% torque/2%ED						20% torque/continuous *6			20% torque/continuous					
Rated input AC voltage/frequency		Three-phase 380 to 480V 50Hz/60Hz														
Permissible AC voltage fluctuation		323 to 528V 50Hz/60Hz														
Permissible frequency fluctuation		±5%														
Power supply capacity (kVA) *7		1.5	2.5	4.5	5.5	9	12	17	20	28	34	41	52	66	80	100
Protective structure *9		Enclosed type (IP20) *8											Open type (IP00)			
Cooling system		Self-cooling			Forced air cooling											
Approx. mass (kg)		3.8	3.8	3.8	3.8	3.8	7.1	7.1	7.5	7.5	13	13	23	35	35	37

Type FR-A740-□□K		75	90	110	132	160	185	220	250	280	315	355	400	450	500
Applicable motor capacity (kW) *1		75	90	110	132	160	185	220	250	280	315	355	400	450	500
Rated capacity (kVA) *2		110	137	165	198	248	275	329	367	417	465	521	587	660	733
Rated current (A)*3		144 (122)	180 (153)	216 (184)	260 (221)	325 (276)	361 (307)	432 (367)	481 (409)	547 (465)	610 (519)	683 (581)	770 (655)	866 (736)	962 (818)
Overload current rating *4		150% 60s, 200% 3s (inverse time characteristics) ambient temperature 50°C													
Voltage*5		Three-phase 380 to 480V													
Regenerative braking torque		10% torque/continuous													
Rated input AC voltage/frequency		Three-phase 380 to 480V 50Hz/60Hz													
Permissible AC voltage fluctuation		323 to 528V 50Hz/60H													
Permissible frequency fluctuation		±5%													
Power supply capacity (kVA) *7		110	137	165	198	248	275	329	367	417	465	521	587	660	733
Protective structure (JEM 1030) *9		Open type (IP00)													
Cooling system		Forced air cooling													
Approx. mass (kg)		50	57	72	72	110	110	175	175	260	260	370	370	370	370

*1. The applicable motor capacity indicated is the maximum capacity applicable for use of the Mitsubishi 4-pole standard motor.

*2. The rated output capacity indicated assumes that the output voltage is 220V for 200V class and 440V for 400V class.

*3. When operating the inverter of 75K or more with a value larger than 2kHz set in Pr. 72 PWM frequency selection, the rated output current is the value in parenthesis.

*4. The % value of the overload current rating indicates the ratio of the overload current to the inverter's rated output current. For repeated duty, allow time for the inverter and motor to return to or below the temperatures under 100% load.

*5. The maximum output voltage does not exceed the power supply voltage. The maximum output voltage can be changed within the setting range. However, the pulse voltage value of the inverter output side voltage remains unchanged at about $\sqrt{2}$ that of the power supply.

*6. For the 11K to 22K capacities, using the dedicated external brake resistor (FR-ABR) will achieve the performance of 100% torque/6%ED.

*7. The power supply capacity varies with the value of the power supply side inverter impedance (including those of the input reactor and cables).

*8. When the hook of the inverter front cover is cut off for installation of the plug-in option, the inverter changes to an open type (IP00).

*9. FR-DU07:IP40 (except for the PU connector)

Common specifications

Control specifications	Control method		Soft-PWM control/high carrier frequency PWM control (V/F control, Advanced magnetic flux vector control and Real sensorless vector control are available) / vector control *1
	Output frequency range		0.2 to 400Hz (The maximum frequency is 120Hz under Real sensorless vector control and vector control.)
	Frequency setting resolution	Analog input	0.015Hz/60Hz (terminal 2, 4: 0 to 10V/12bit) 0.03Hz/60Hz (terminal 2, 4: 0 to 5V/11bit, 0 to 20mA/about 11bit, terminal 1: 0 to ±10V/12bit)
		Digital input	0.01Hz
	Frequency accuracy	Analog input	Within ±0.2% of the max. output frequency (25°C±10°C)
		Digital input	Within 0.01% of the set output frequency
	Voltage/frequency characteristics		Base frequency can be set from 0 to 400Hz Constant torque/variable torque pattern or adjustable 5 points V/F can be selected
	Starting torque		200% 0.3Hz (0.4K to 3.7K), 150% 0.3Hz (5.5K or more) (under Real sensorless vector control or vector control *1)
	Torque boost		Manual torque boost
	Acceleration/deceleration time setting		0 to 3600s (acceleration and deceleration can be set individually), linear or S-pattern acceleration/deceleration mode, backlash measures acceleration/deceleration mode are available.
DC injection brake		Operation frequency (0 to 120Hz), operation time (0 to 10s), operation voltage (0 to 30%) can be changed	
Stall prevention operation level		Operation current level can be set (0 to 220% adjustable), whether to use the function or not can be selected	
Torque limit level		Torque limit value can be set (0 to 400% variable)	
Operation specifications	Frequency setting signal	Analog input	• Terminal 2, 4: 0 to 10V, 0 to 5V, 4 to 20mA (0 to 20mA) can be selected • Terminal 1: -10 to +10V, -5 to +5V can be selected
		Digital input	Input using the setting dial of the operation panel or parameter unit Four-digit BCD or 16 bit binary (when used with option FR-A7AX)
	Start signal		Forward and reverse rotation or start signal automatic self-holding input (3-wire input) can be selected.
	Input signals (twelve terminals)		The following signals can be assigned to Pr. 178 to Pr. 189 (input terminal function selection): multi speed selection, remote setting, stop-on-contact, second function selection, third function selection, terminal 4 input selection, JOG operation selection, selection of automatic restart after instantaneous power failure, flying start, external thermal relay input, inverter run enable signal (FR-HC/FR-CV connection), FR-HC connection (instantaneous power failure detection), PU operation/external inter lock signal, external DC injection brake operation start, PID control enable terminal, brake opening completion signal, PU operation/External operation switchover, load pattern selection forward rotation reverse rotation boost, V/F switching, load torque high-speed frequency, S-pattern acceleration/deceleration C switchover, pre-excitation, output stop, start self-holding selection, control mode changing, torque limit selection, start-time tuning start external input, torque bias selection 1, 2*1, P/PI control switchover, forward rotation command, reverse rotation command, inverter reset, PTC thermistor input, PID forward reverse operation switchover, PU-NET operation switchover, NET-External operation switchover, command source switchover, simple position pulse train sign*1, simple position droop pulse clear*1, DC feeding operation permission, DC feeding cancel, magnetic flux decay output shutoff.
	Pulse train input		100kpps
	Operational functions		Maximum/minimum frequency setting, frequency jump operation, external thermal relay input selection, polarity reversible operation, automatic restart after instantaneous power failure operation, electronic bypass operation, forward/reverse rotation prevention, remote setting, brake sequence, second function, third function, multi-speed operation, original operation continuation at instantaneous power failure, stop-on-contact control, load torque high speed frequency control, droop control, regeneration avoidance, slip compensation, operation mode selection, offline auto tuning function, online auto tuning function, PID control, computer link operation (RS-485), motor end orientation *1, machine end orientation *2, pre-excitation, notch filter, machine analyzer *1, easy gain tuning, speed feed forward, and torque bias *1
	Output signals		The following signals can be assigned to Pr. 190 to Pr. 196 (output terminal function selection): inverter running, inverter running/start command on, up-to-frequency, instantaneous power failure/undervoltage, overload warning, output frequency (speed) detection, second output frequency (speed) detection, third output frequency (speed) detection, regenerative brake prealarm, electronic thermal relay function pre-alarm, PU operation mode, inverter operation ready, output current detection, zero current detection, PID lower limit, PID upper limit, PID forward rotation reverse rotation output, electronic bypass MC1, electronic bypass MC2, electronic bypass MC3, orientation completion *1, orientation fault *1, brake opening request, fan fault output, heatsink overheat pre-alarm, deceleration at an instantaneous power failure, PID control activated, during retry, PID output interruption, position control preparation ready *1, DC feeding, life alarm, fault output 1, 2, 3 (power-off signal), power savings average value update timing, current average monitor, maintenance timer alarm, remote output, forward rotation output *1, reverse rotation output *1, low speed output, torque detection, regenerative status output *1, start-time tuning completion, in-position completion *1, alarm output and fault output. Alarm code of the inverter can be output (4 bit) from the open collector.
	Open collector output (5 terminals) relay output (1 terminal)		
	Operating status		In addition to above, the following signal can be assigned to Pr.313 to Pr. 319 (extension output terminal function selection): control circuit capacitor life, main circuit capacitor life, cooling fan life, inrush current limit circuit life. (only positive logic can be set for extension terminals of the FR-A7AR)
	Pulse train output		50kpps
For meter Pulse train output (Max. 2.4kHz: one terminal) Analog output (Max. 10VDC: one terminal)		The following signals can be assigned to Pr. 54 FM terminal function selection (pulse train output) and Pr. 158 AM terminal function selection (analog output): output frequency, motor current (steady or peak value), output voltage, frequency setting, operation speed, motor torque, converter output voltage (steady or peak value), electronic thermal relay function load factor, input power, output power, load meter, motor excitation current, reference voltage output, motor load factor, power saving effect, regenerative brake duty, PID set point, PID measured value, motor output, torque command, torque current command, and torque monitor.	
Indication	Operation panel (FR-DU07) Parameter unit (FR-PU07)	Operating status	The following operating status can be displayed: Output frequency, motor current (steady or peak value), output voltage, frequency setting, running speed, motor torque, overload, converter output voltage (steady or peak value), electronic thermal relay function load factor, input power, output power, load meter, motor excitation current, position pulse, cumulative energization time, orientation status *1, actual operation time, motor load factor, cumulative power, energy saving effect, cumulative saving power, regenerative brake duty, PID set point, PID measured value, PID deviation, inverter I/O terminal monitor, input terminal option monitor*3, output terminal option monitor*3, option fitting status*4, terminal assignment status*4, torque command, torque current command, feed back pulse*1, motor output
		Fault definition	Fault definition is displayed when a fault occurs, the output voltage/current/frequency/cumulative energization time right before the fault occurs and past 8 fault definitions are stored.
	Interactive guidance		Function (help) for operation guide*4
Protective/warning function	Protective function		Overcurrent during acceleration, overcurrent during constant speed, overcurrent during deceleration, overvoltage during acceleration, overvoltage during constant speed, overvoltage during deceleration, inverter protection thermal operation, motor protection thermal operation, heatsink overheat, instantaneous power failure occurrence, undervoltage, input phase loss *7, motor overload, output side earth (ground) fault overcurrent, output short circuit, main circuit element overheat, output phase loss, external thermal relay operation*7, PTC thermistor operation*7, option fault, parameter error, PU disconnection, retry count excess*7, CPU fault, operation panel power supply short circuit, 24VDC power output short circuit, output current detection value excess*7, inrush current limit circuit fault, communication fault (inverter), USB fault, opposite rotation deceleration fault*7, analog input fault, brake transistor alarm, speed deviation large *1*7, overspeed *1*7, position error large *1*7, signal loss detection *1*7, brake sequence fault*7, encoder phase error *1*7
	Warning function		Fan fault, overcurrent stall prevention, overvoltage stall prevention, regenerative brake prealarm*7, electronic thermal relay function prealarm, PU stop, maintenance timer alarm*3 *7, parameter write error, copy operation error, operation panel lock, parameter copy alarm, speed limit indication
Environment	Surrounding air temperature		-10°C to +50°C (non-freezing)
	Ambient humidity		90%RH maximum (non-condensing)
	Storage temperature*4		-20°C to +65°C
	Atmosphere		Indoors (without corrosive gas, flammable gas, oil mist, dust and dirt etc.)
Altitude/vibration		Maximum 1000m above sea level, 5.9m/s ² or less*6 at 10 to 55Hz (direction of X, Y, Z axes)	

*1. Available only when the option (FR-A7AP/FR-A7AL) is mounted.

*2. Available only when the option (FR-A7AL) is mounted.

*3. Can be displayed only on the operation panel (FR-DU07).

*4. Can be displayed only on the parameter unit (FR-PU07).

*5. Temperature applicable for a short period in transit, etc.

*6. 2.9m/s² or less for the 160K or more.

*7. This protective function does not function in the initial status.

- Features
- Peripheral Devices
- Standard Specifications
- Outline Dimension Drawings
- Terminal Connection Diagram Terminal Specification Explanation
- Operation Panel
- Parameter List
- Explanations of Parameters
- Protective Functions
- Options
- Instructions
- Motor
- Compatibility
- Warranty
- Inquiry

Outline Dimension Drawings

- FR-A720-0.4K, 0.75K

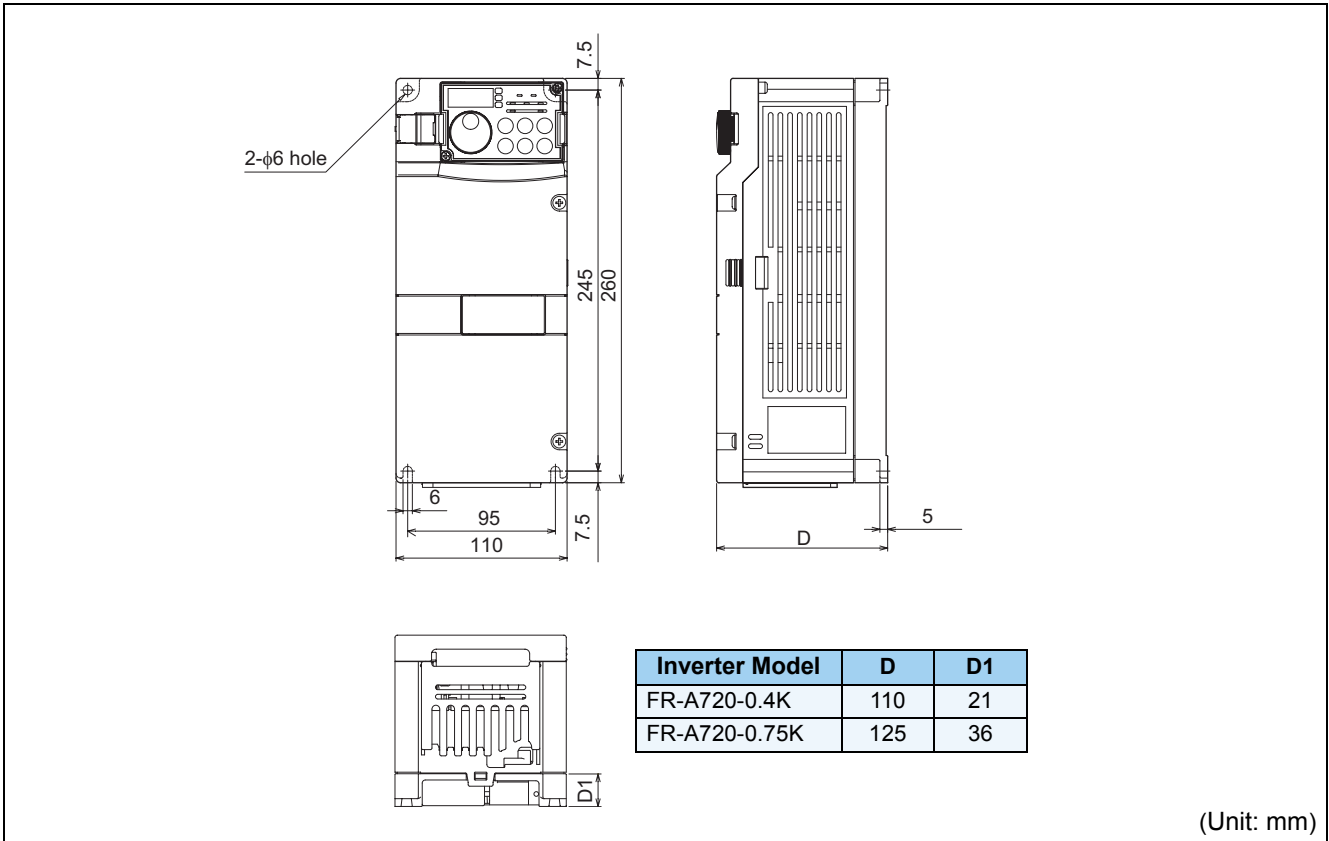

- FR-A720-1.5K, 2.2K, 3.7K
- FR-A740-0.4K, 0.75K, 1.5K, 2.2K, 3.7K

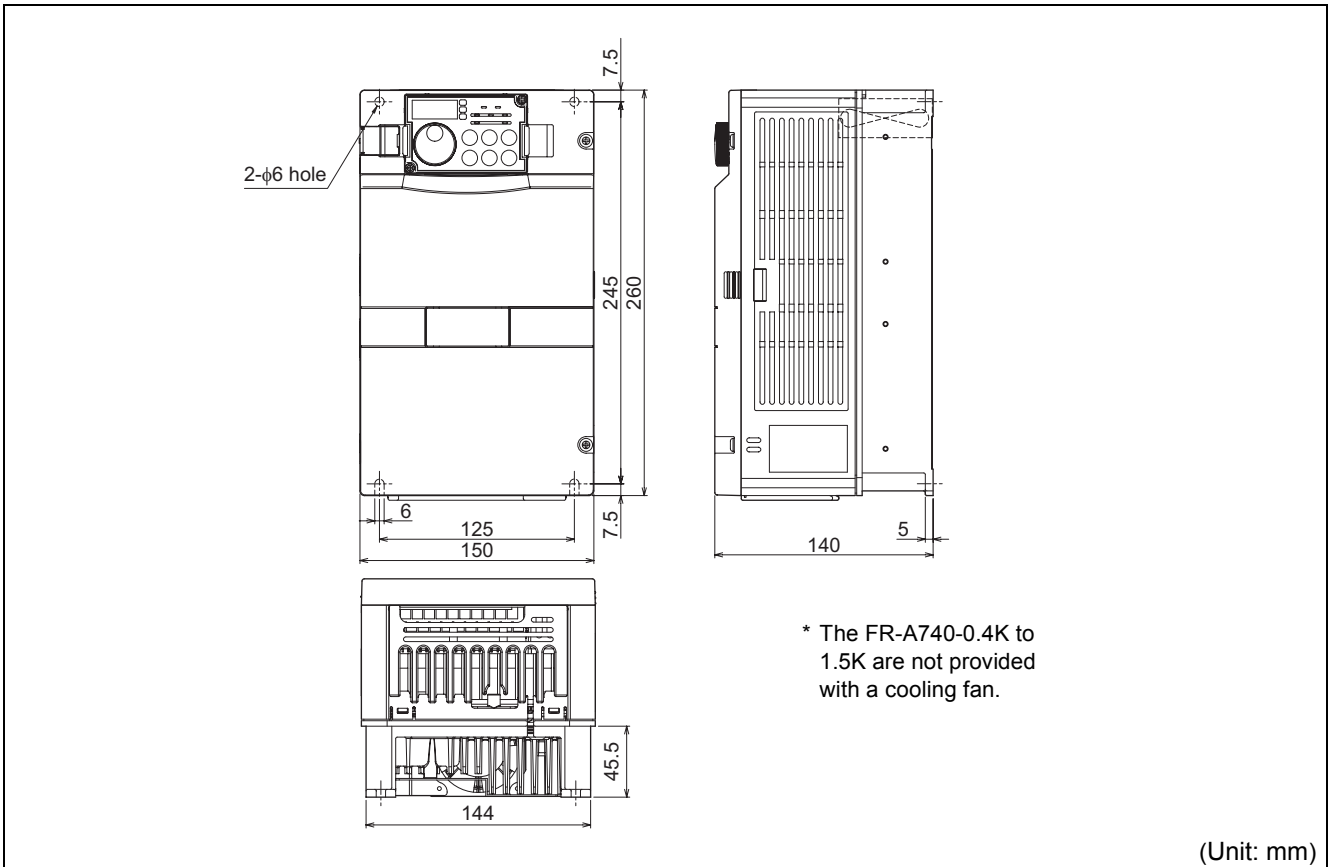

- FR-A720-5.5K, 7.5K, 11K
- FR-A740-5.5K, 7.5K, 11K, 15K

Inverter Model	H	H1	D	D1
FR-A720-5.5K, 7.5K FR-A740-5.5K, 7.5K	260	245	170	84
FR-A720-11K FR-A740-11K, 15K	300	285	190	101.5

(Unit: mm)

- FR-A720-15K, 18.5K, 22K
- FR-A740-18.5K, 22K

(Unit: mm)

- Features
- Peripheral Devices
- Standard Specifications
- Outline Dimension Drawings
- Terminal Connection Diagram Terminal Specification Explanation
- Operation Panel
- Parameter List
- Explanations of Parameters
- Protective Functions
- Options
- Instructions
- Motor
- Compatibility
- Warranty
- Inquiry

- FR-A720-30K, 37K, 45K, 55K
- FR-A740-30K, 37K, 45K, 55K

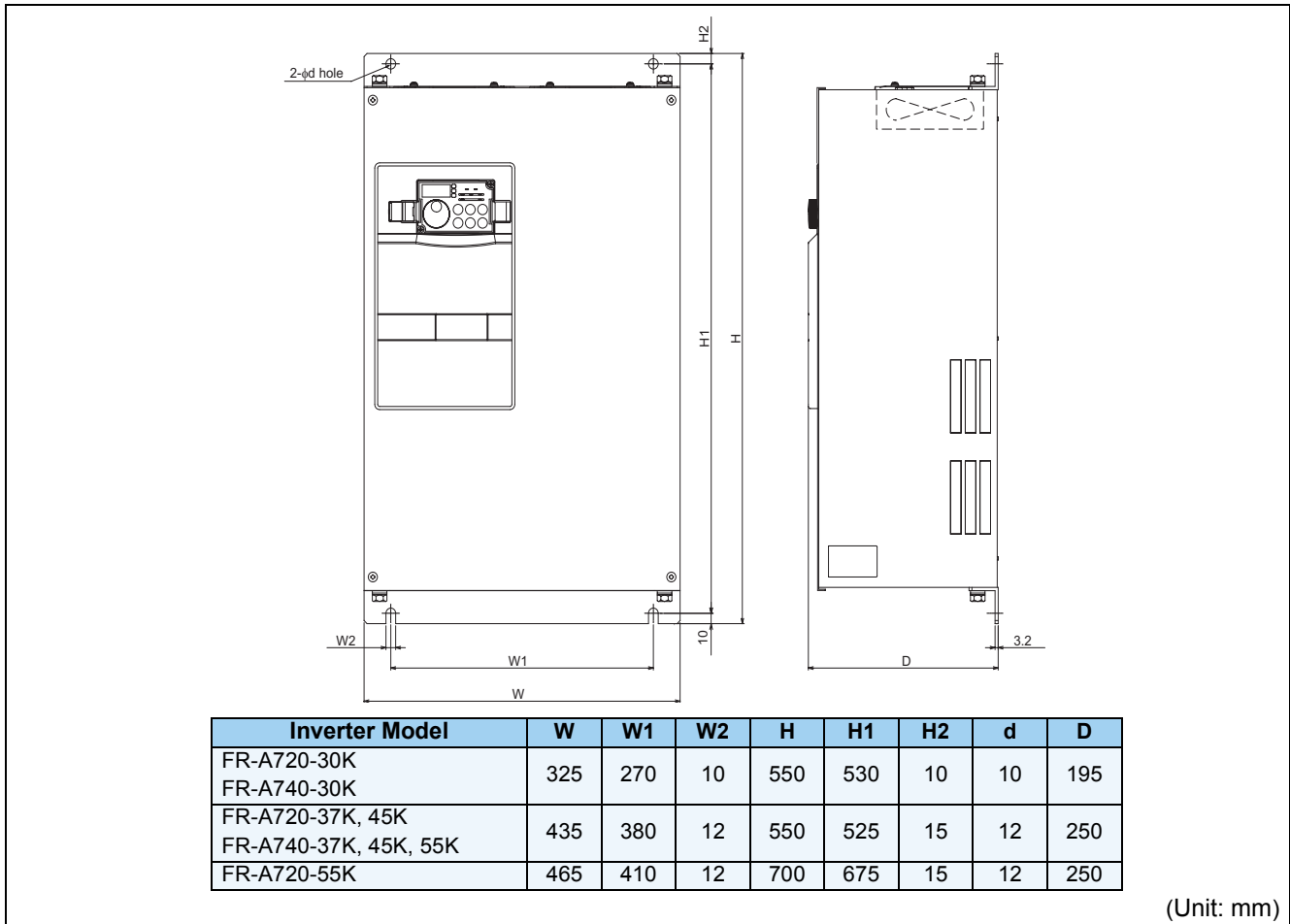

- FR-A740-75K, 90K

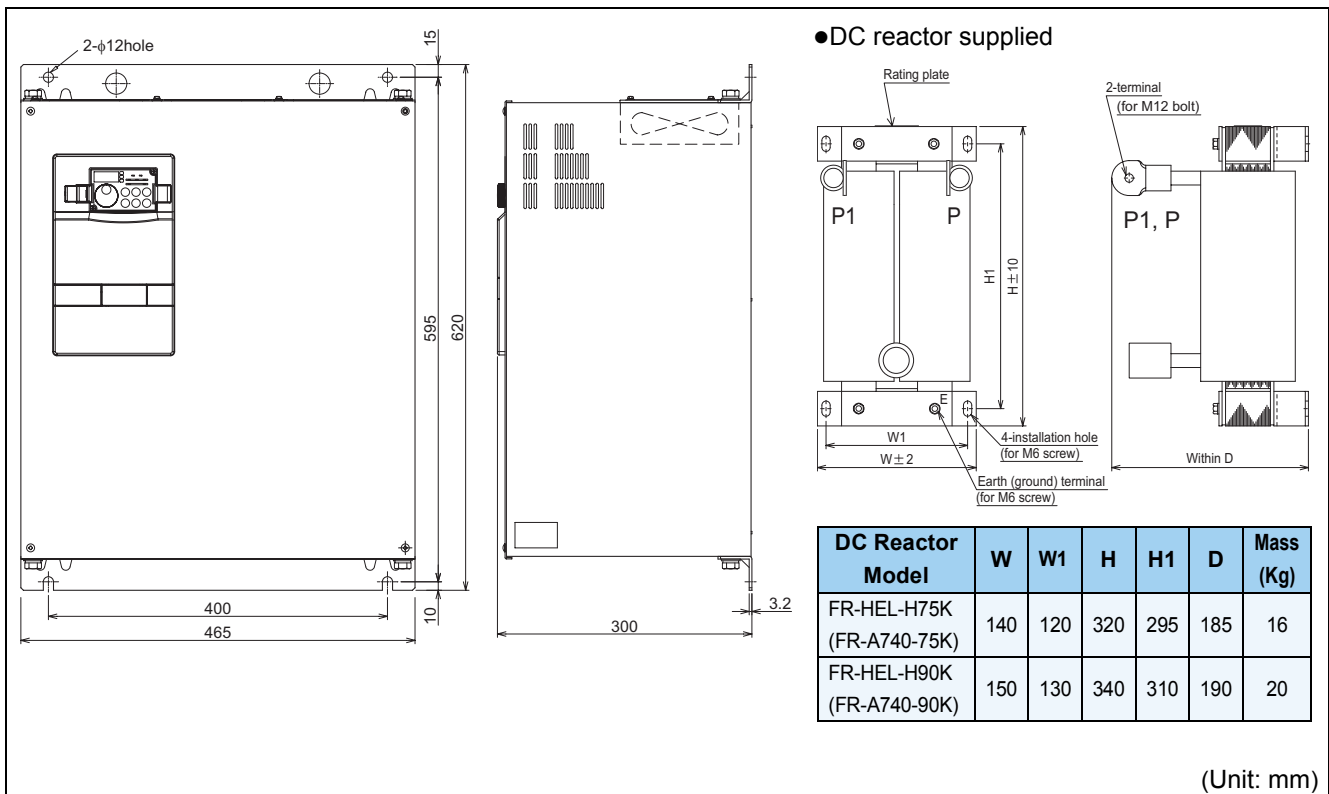

- FR-A720-75K, 90K
- FR-A740-110K, 132K

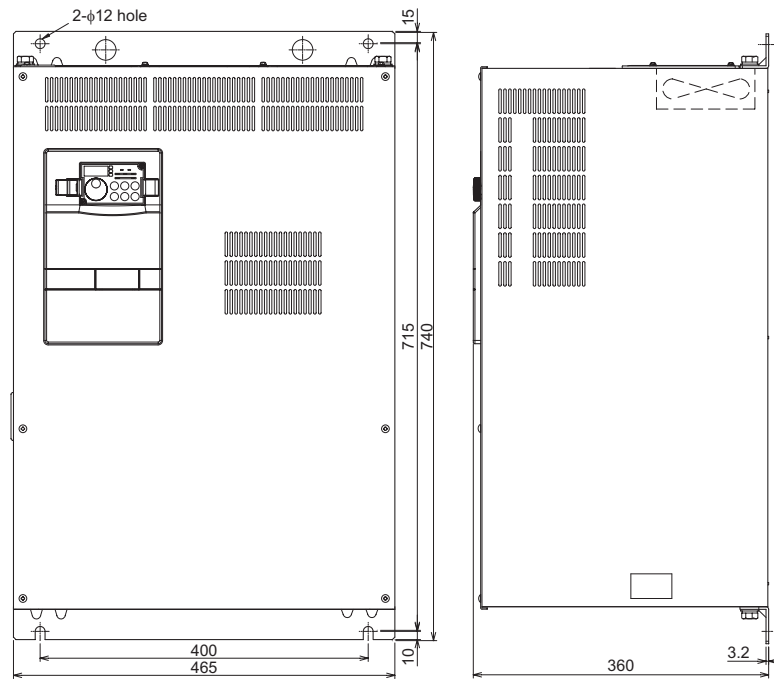

- DC reactor supplied

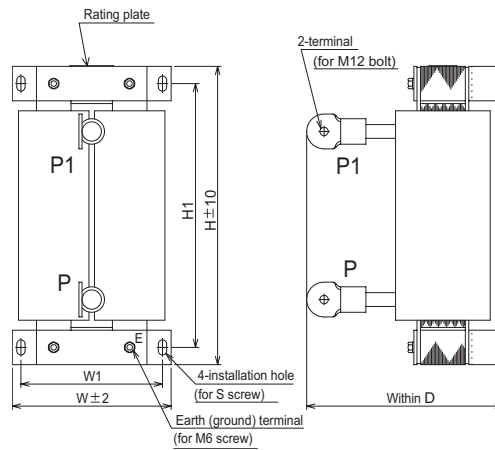

DC Reactor Model	W	W1	H	H1	D	S	Mass (kg)
FR-HEL-75K (FR-A720-75K)	150	130	340	310	190	M6	17
FR-HEL-90K (FR-A720-90K)	150	130	340	310	200	M6	19
FR-HEL-H110K (FR-A740-110K)	150	130	340	310	195	M6	22
FR-HEL-H132K (FR-A740-132K)	175	150	405	370	200	M8	26

(Unit: mm)

- Features
- Peripheral Devices
- Standard Specifications
- Outline Dimension Drawings
- Terminal Connection Diagram Terminal Specification Explanation
- Operation Panel
- Parameter List
- Explanations of Parameters
- Protective Functions
- Options
- Instructions
- Motor
- Compatibility
- Warranty
- Inquiry

●FR-A740-160K, 185K

3-φ12 hole

15

985

1010

49

200

200

49

498

12

10

380

3.2

450

148.5

214.5

185

●DC reactor supplied

Rating plate

P1

P

W1

W±2

H1

H±10

4-installation hole (for S screw)

Earth (ground) terminal (for M6 screw)

2-terminal (for M12 bolt)

Within D

DC Reactor Model	W	W1	H	H1	D	S	Mass (kg)
FR-HEL-H160K (FR-A740-160K)	175	150	405	370	205	M8	28
FR-HEL-H185K (FR-A740-185K)	175	150	405	370	240	M8	29

(Unit: mm)

●FR-A740-220K, 250K, 280K

3-φ12 hole

12

984

1010

300

300

680

380

3.2

148

214

185

●DC reactor supplied

Rating plate

2-M6 eye nut (only for FR-HEL-H220K)

P1

P

150±1

175±2

370±10

405±10

4-installation hole (for M8 screw)

Earth (ground) terminal (for M6 screw)

2-terminal (for M12 bolt)

Within 240

* Remove the eye nut after installation of the product.

DC Reactor Model	W	W1	H	H1	D	S	S1	S2	φ	Mass (kg)
FR-HEL-H220K (FR-A740-220K)	175	150	405	370	240	M8	M6	M6	M12	30
FR-HEL-H250K (FR-A740-250K)	190	165	440	400	250	M8	M8	M8	M12	35
FR-HEL-H280K (FR-A740-280K)	190	165	440	400	255	M8	M8	M8	M16	38

(Unit: mm)

●FR-A740-315K, 355K

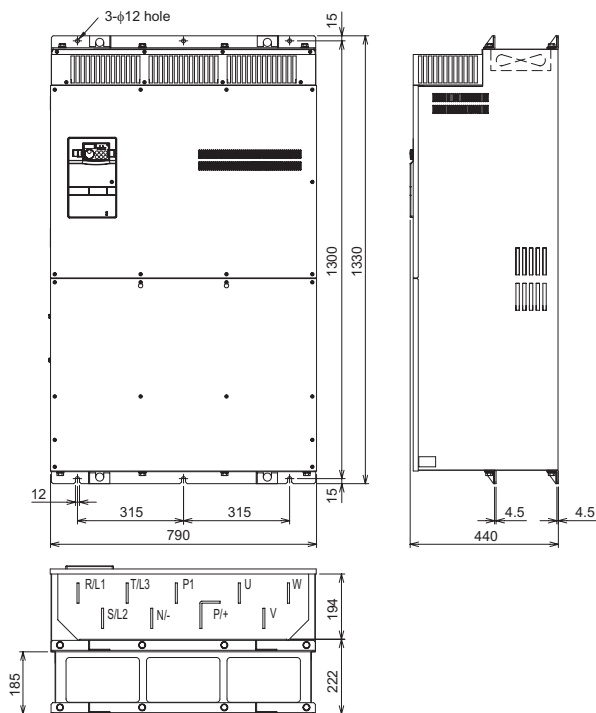

●DC reactor supplied

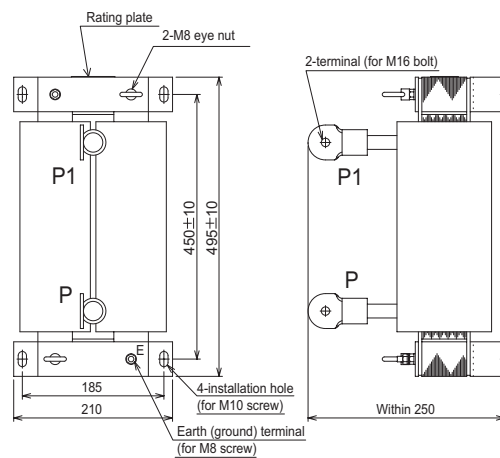

* Remove the eye nut after installation of the product.

DC Reactor Model	Mass (kg)
FR-HEL-H315K (FR-A740-315K)	42
FR-HEL-H355K (FR-A740-355K)	46

(Unit: mm)

Features

Peripheral Devices

Standard Specifications

Outline Dimension Drawings

Terminal Connection Diagram Terminal Specification Explanation

Operation Panel

Parameter List

Explanations of Parameters

Protective Functions

Options

Instructions

Motor

Compatibility

Warranty

Inquiry

●FR-A740-400K, 450K, 500K

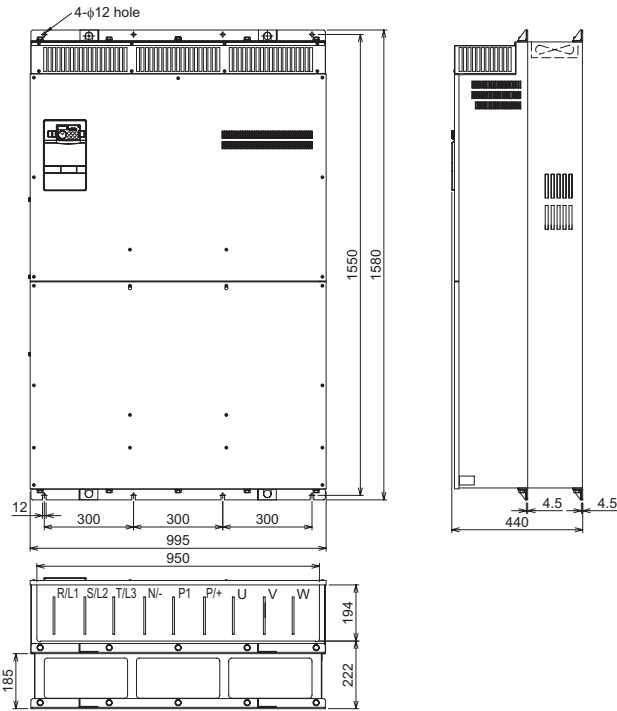

●DC reactor supplied

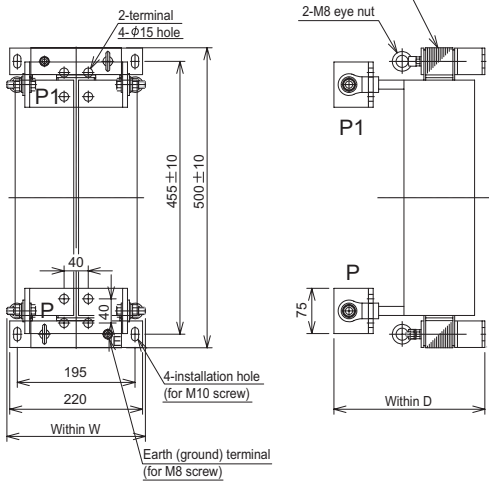

* Remove the eye nut after installation of the product.

●DC reactor supplied

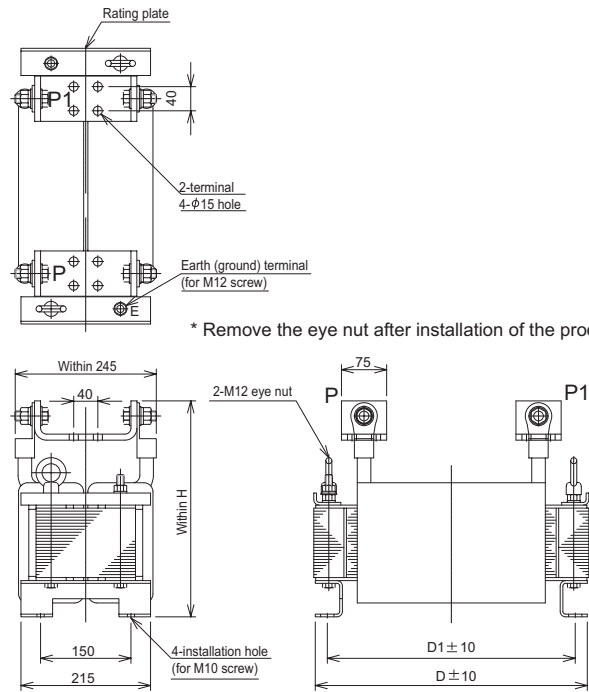

* Remove the eye nut after installation of the product.

DC Reactor Model	W	D	Mass (kg)
FR-HEL-H400K (FR-A740-400K)	235	250	50
FR-HEL-H450K (FR-A740-450K)	240	270	57

DC Reactor Model	H	D	D1	Mass (kg)
FR-HEL-H500K (FR-A740-500K)	345	455	405	67

(Unit: mm)

● Operation panel (FR-DU07)

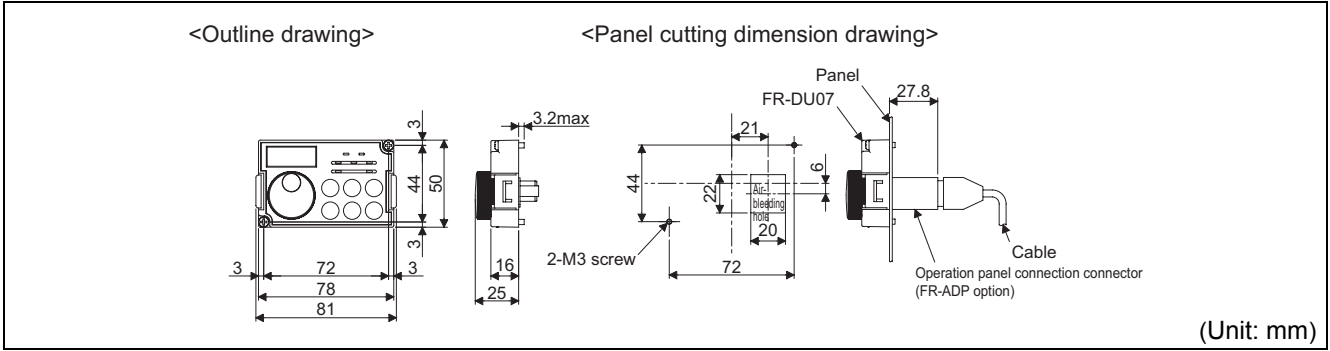

● Parameter unit (option) (FR-PU07)

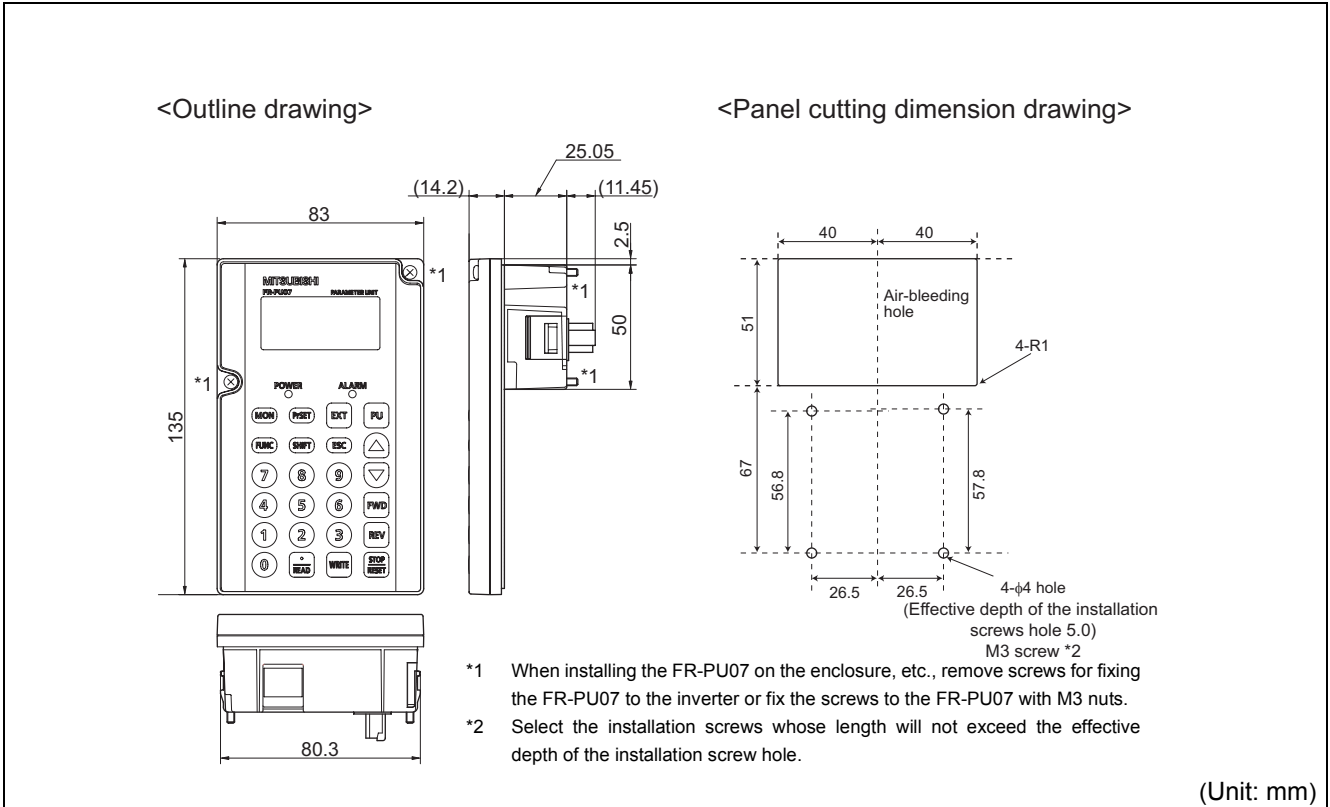

- Features
- Peripheral Devices
- Standard Specifications
- Outline Dimension Drawings
- Terminal Connection Diagram Terminal Specification Explanation
- Operation Panel
- Parameter List
- Explanations of Parameters
- Protective Functions
- Options
- Instructions
- Motor
- Compatibility
- Warranty
- Inquiry

Heatsink protrusion procedure

When encasing the inverter in an enclosure, the generated heat amount in an enclosure can be greatly reduced by installing the heatsink portion of the inverter outside the enclosure.

When installing the inverter in a compact enclosure, etc., this installation method is recommended. For the 160K or more, a heatsink can be protruded outside the enclosure without using an attachment.

●When using a heatsink protrusion attachment (FR-A7CN)

For the FR-A720-1.5K to 90K and FR-A740-0.4K to 132K, a heatsink can be protruded outside the enclosure using a heatsink protrusion attachment (FR-A7CN). Refer to the instruction manual of the heatsink protrusion attachment (FR-A7CN) for details.

●Drawing after attachment installation (when used with the FR-A7CN)

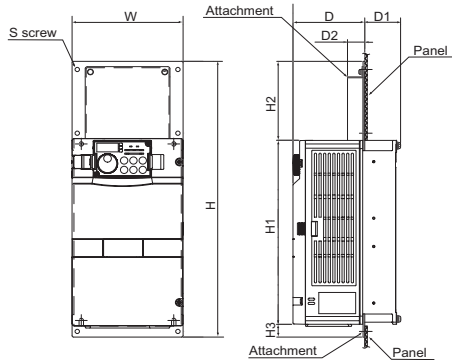

Type	W	H	H1	H2	H3	D	D1	D2	S
FR-A7CN01	150	389.5	260	111.5	18	97	48.4	23.3	M5
FR-A7CN02	245	408.5	260	116.5	32	86	89.4	12.3	M5
FR-A7CN03	245	448.5	300	116.5	32	89	106.4	20	M5
FR-A7CN04	280	554	400	122	32	88.5	110.6	45.3	M8
FR-A7CN05	338	645	480	130	35	123.5	71.5	105	M8
FR-A7CN06	338	645	480	130	35	123.5	71.5	83.5	M8
FR-A7CN07	451	650	465	145	40	96	154	55	M10
FR-A7CN08	510	725	535	150	40	116.5	183.5	45	M10
FR-A7CN09	510	725	535	150	40	116.5	183.5	45	M10
FR-A7CN10	510	845	655	150	40	176.5	183.5	45	M10
FR-A7CN11	510	805	615	150	40	97	153	45	M10

(Unit: mm)

●Panel cut dimension drawing (when used with the FR-A7CN)

FR-A7CN01

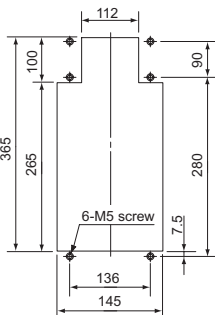

FR-A7CN02

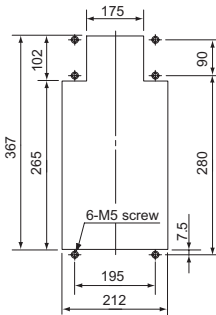

FR-A7CN03

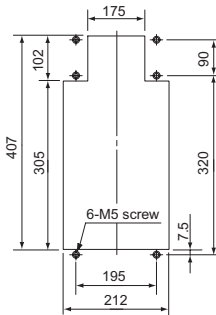

FR-A7CN04

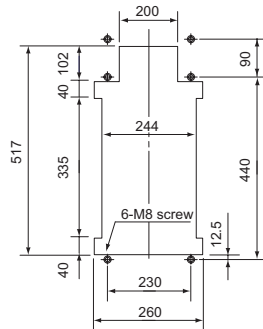

FR-A7CN05

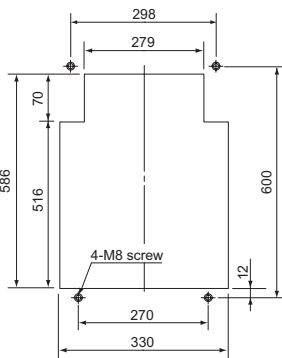

FR-A7CN06

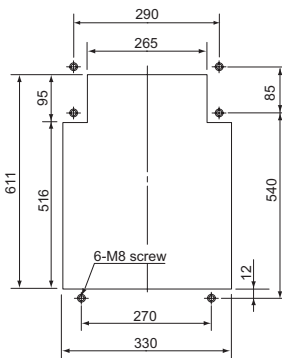

FR-A7CN07

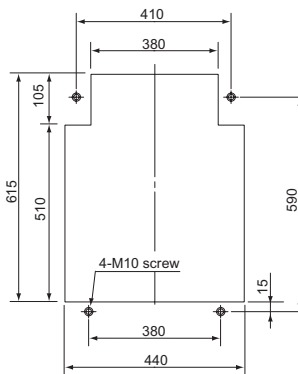

FR-A7CN08

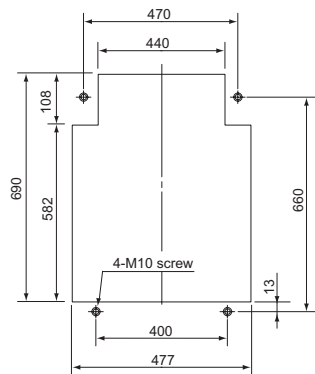

(Unit: mm)

●When using a heatsink protrusion attachment (FR-A7CN)

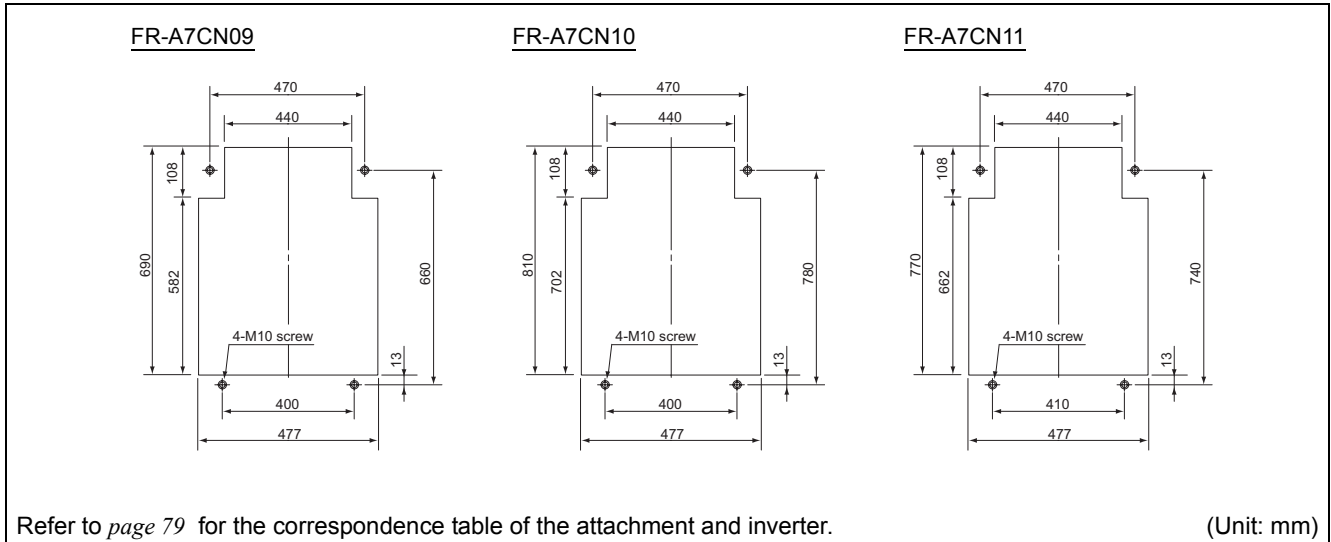

●Protrusion of heatsink of the FR-A740-160K or more

- Panel cutting
Cut the panel of the enclosure according to the inverter capacity.

●FR-A740-160K, 185K

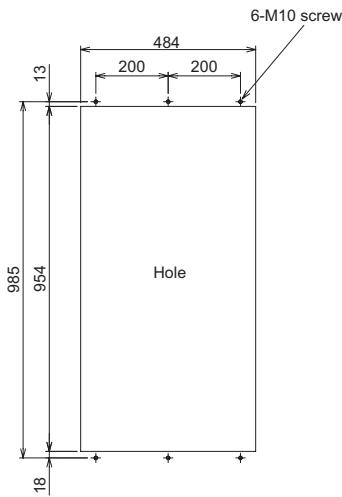

●FR-A740-220K, 250K, 280K

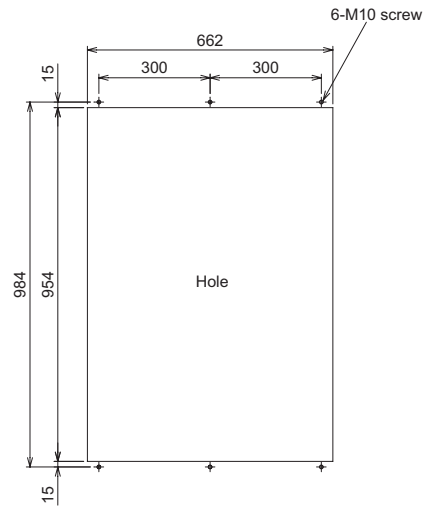

●FR-A740-315K, 355K

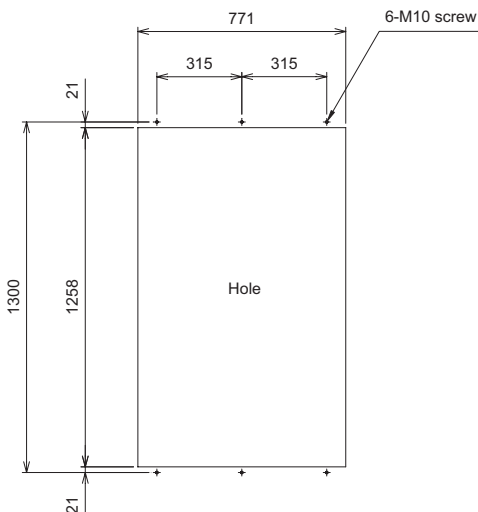

●FR-A740-400K, 450K, 500K

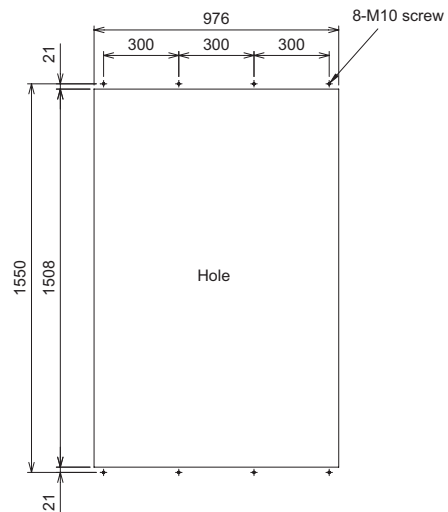

(Unit: mm)

- Features
- Peripheral Devices
- Standard Specifications
- Outline Dimension Drawings
- Terminal Connection Diagram
- Terminal Specification Explanation
- Operation Panel
- Parameter List
- Explanations of Parameters
- Protective Functions
- Options
- Instructions
- Motor
- Compatibility
- Warranty
- Inquiry

● Shift and removal of a rear side installation frame

● FR-A740-160K to 280K

One installation frame is attached to each of the upper and lower part of the inverter. Change the position of the rear side installation frame on the upper and lower side of the inverter to the front side as shown on the right. When changing the installation frames, make sure that the installation orientation is correct.

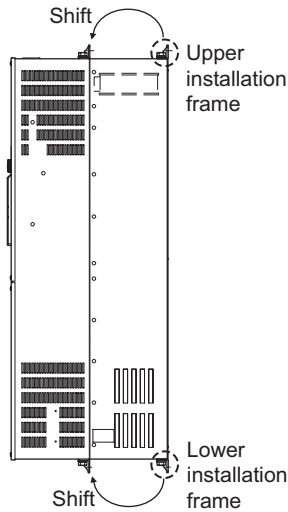

● FR-A740-315K or more

Two installation frames each are attached to the upper and lower part of the inverter. Remove the rear side installation frame on the upper and lower side of the inverter as shown below.

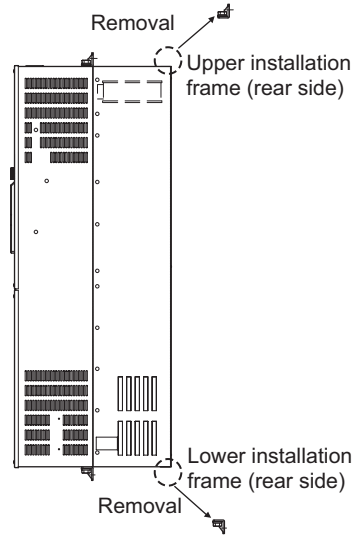

● Installation of the inverter

Push the inverter heatsink portion outside the enclosure and fix the enclosure and inverter with upper and lower installation frame.

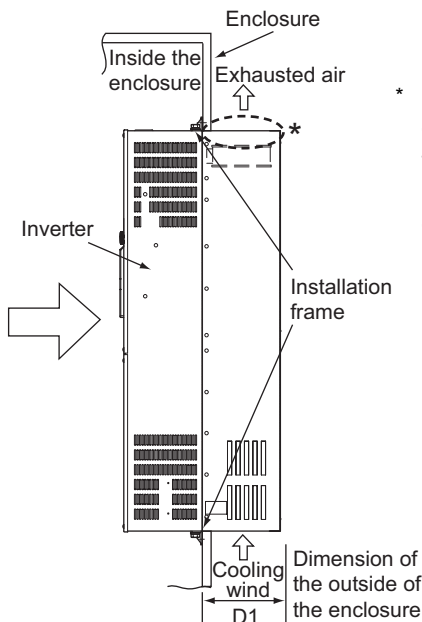

* For the FR-A740-160K or more, there are finger guards behind the enclosure. Therefore, the thickness of the panel should be less than 10mm (*1) and also do not place anything around finger guards to avoid contact with the finger guards.

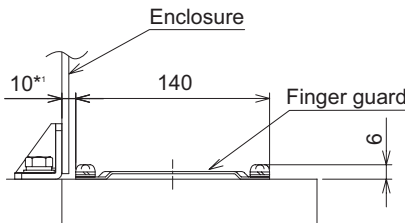

Inverter Type	D1
FR-A740-160K, 185K	185
FR-A740-220K to 500K	184

(Unit: mm)

CAUTION

- Having a cooling fan, the cooling section which comes out of the enclosure can not be used in the environment of water drops, oil, mist, dust, etc.
- Be careful not to drop screws, dust etc. into the inverter and cooling fan section.

Terminal Connection Diagram

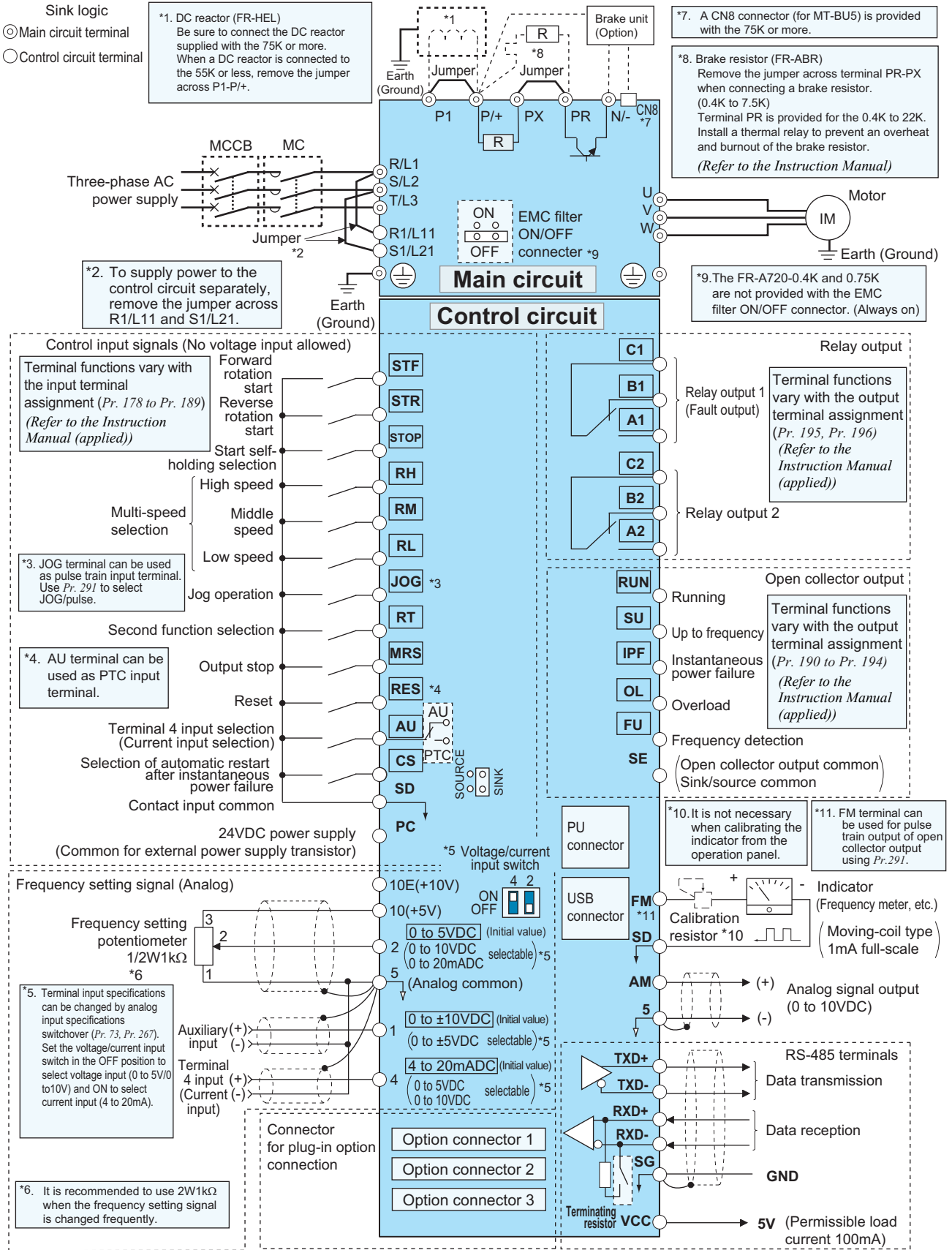

CAUTION

- To prevent a malfunction caused by noise, separate the signal cables more than 10cm from the power cables.
- Be sure to earth (ground) the inverter and motor before use.
- This connection diagram assumes that the control circuit is sink logic (initial setting). Refer to the instruction manual for the connection in the case of source logic.

Features

Peripheral Devices

Standard Specifications

Outline Dimension Drawings

Terminal Connection Diagram Terminal Specification Explanation

Operation Panel

Parameter List

Explanations of Parameters

Protective Functions

Options

Instructions

Motor

Compatibility

Warranty

Inquiry

Terminal Specification Explanation

Type	Terminal Symbol	Terminal Name	Description			
Main circuit	R/L1, S/L2, T/L3	AC power input	Connect to the commercial power supply.			
	U, V, W	Inverter output	Connect a three-phase squirrel-cage motor.			
	R1/L11, S1/L21	Power supply for control circuit	Connected to the AC power supply terminals R/L1 and S/L2. To retain alarm display and alarm output, apply external power to this terminal.			
	P/+, PR	Brake resistor connection	Remove the jumper from terminals PR-PX (7.5K or less) and connect an optional brake resistor (FR-ABR) across terminals P/+ -PR. The PR terminal is provided for the 22K or less.			
	P/+, N/-	Brake unit connection	Connect the brake unit (FR-BU and BU, MT-BU5), power regeneration common converter (FR-CV) or regeneration common converter (MT-RC) and high power factor converter (FR-HC, MT-HC).			
	P/+, P1	DC reactor connection	For the 55K or less, remove the jumper across terminals P/+ -P1 and connect a DC reactor. (For the 75K or more, a DC reactor is supplied as standard.)			
	PR, PX	Built-in brake circuit connection	When the jumper is connected across terminals PX-PR (initial status), the built-in brake circuit is valid. The PX terminal is provided for the 7.5K or less.			
		Earth (Ground)	For earthing (grounding) the inverter chassis. Must be earthed (grounded).			
Control circuit/input signal	Contact input	STF	Forward rotation start	Turn on the STF signal to start forward rotation and turn it off to stop.	When the STF and STR signals are turned on simultaneously, the stop command is given.	
		STR	Reverse rotation start	Turn on the STR signal to start reverse rotation and turn it off to stop.		
		STOP	Start self-holding selection	Turn on the STOP signal to self-hold the start signal.		
	Control circuit/input signal	RH, RM, RL	Multi-speed selection	Multi-speed can be selected according to the combination of RH, RM and RL signals.		
		JOG	Jog mode selection	Turn on the JOG signal to select Jog operation (initial setting) and turn on the start signal (STF or STR) to start Jog operation.		
			Pulse train input	JOG terminal can be used as pulse train input terminal. To use as pulse train input terminal, the Pr.291 setting needs to be changed. (maximum input pulse: 100kpulses/s)		
		RT	Second function selection	Turn on the RT signal to select second function selection. When the second function such as "Second torque boost" and "Second V/F (base frequency)" are set, turning on the RT signal selects these functions.		
		MRS	Output stop	Turn on the MRS signal (20ms or more) to stop the inverter output. Use to shut off the inverter output when stopping the motor by electromagnetic brake.		
		RES	Reset	Used to reset alarm output provided when protective circuit is activated. Turn on the RES signal for more than 0.1s, then turn it off. Recover about 1s after reset is cancelled.		
		AU	Terminal 4 input selection	Terminal 4 is made valid only when the AU signal is turned on. Turning the AU signal on makes terminal 2 invalid.		
			PTC input	AU terminal is used as PTC input terminal (thermal protection of the motor). When using it as PTC input terminal, set the AU/PTC switch to PTC.		
		CS	Selection of automatic restart after instantaneous power failure	When the CS signal is left on, the inverter restarts automatically at power restoration. Note that restart setting is necessary for this operation. In the initial setting, a restart is disabled.		
		SD	Contact input common (sink)	Common terminal for contact input terminal (sink logic) and terminal FM. Common output terminal for 24VDC 0.1A power supply (PC terminal). Isolated from terminals 5 and SE.		
PC	External transistor common, 24VDC power supply, contact input common (source)	When connecting the transistor output (open collector output), such as a programmable controller, when sink logic is selected, connect the external power supply common for transistor output to this terminal to prevent a malfunction caused by undesirable currents. Can be used as 24VDC 0.1A power supply. When source logic has been selected, this terminal serves as a contact input common.				
Frequency setting	10E	Frequency setting power supply	When connecting a frequency setting potentiometer at an initial status, connect it to terminal 10.		10VDC, permissible load current 10mA	
	10		Change the input specifications of terminal 2 when connecting it to terminal 10E.		5VDC, permissible load current 10mA	
	2	Frequency setting (voltage)	Inputting 0 to 5VDC (or 0 to 10V, 4 to 20mA) provides the maximum output frequency at 5V (10V, 20mA) and makes input and output proportional. Use Pr.73 to switch from among input 0 to 5VDC (initial setting), 0 to 10VDC, and 4 to 20mA. Set the voltage/current input switch in the ON position to select current input (0 to 20mA).		Voltage input: Input resistance 10kΩ ± 1kΩ Maximum permissible	
	4	Frequency setting (current)	Inputting 4 to 20mADC (or 0 to 5V, 0 to 10V) provides the maximum output frequency at 20mA and makes input and output proportional. This input signal is valid only when the AU signal is on (terminal 2 input is invalid). Use Pr.267 to switch from among input 4 to 20mA (initial setting), 0 to 5VDC, and 0 to 10VDC. Set the voltage/current input switch in the OFF position to select voltage input (0 to 5V/0 to 10V). Use Pr. 858 to switch terminal functions.		voltage 20VDC Current input: Input resistance 245Ω ± 5Ω Maximum permissible current 30mA	
	1	Frequency setting auxiliary	Inputting 0 to ±5VDC or 0 to ±10VDC adds this signal to terminal 2 or 4 frequency setting signal. Use Pr.73 to switch between input 0 to ±5VDC and 0 to ±10VDC (initial setting) input. Input resistance 10kΩ ±1kΩ Maximum permissible voltage ±20VDC			
5	Frequency setting common	Common terminal for frequency setting signal (terminal 2, 1 or 4) and analog output terminal AM. Do not earth (ground)				

Type	Terminal Symbol	Terminal Name	Description		
Control circuit/input signal	Relay	A1, B1, C1	Relay output 1 (alarm output) 1 changeover contact output indicates that the inverter protective function has activated and the output stopped. Alarm: discontinuity across B-C (continuity across A-C), Normal: continuity across B-C (discontinuity across A-C) Contact capacity 230VAC 0.3A (power factor =0.4) 30VDC 0.3A		
		A2, B2, C2	Relay output 2 1 changeover contact output, contact capacity 230VAC, 0.3A (power factor=0.4) 30VDC 0.3A		
	Open collector	RUN	Inverter running	Switched low when the inverter output frequency is equal to or higher than the starting frequency (initial value 0.5Hz). Switched high during stop or DC injection brake operation.*1	
		SU	Up to frequency	Switched low when the output frequency reaches within the range of ±10% (initial value) of the set frequency. Switched high during acceleration/deceleration and at a stop.*1	
		OL	Overload alarm	Switched low when stall prevention is activated by the stall prevention function. Switched high when stall prevention is cancelled.*1	
		IPF	Instantaneous power failure	Switched low when an instantaneous power failure and under voltage protections are activated.*1	
		FU	Frequency detection	Switched low when the inverter output frequency is equal to or higher than the preset detected frequency and high when less than the preset detected frequency.*1	
	SE	Open collector output common	Common terminal for terminals RUN, SU, OL, IPF, FU	Alarm code (4bit) output (Refer to page 53.) Permissible load 24VDC(27VDC maximum) 0.1A (a voltage drop is 2.8V maximum when the signal is on)	
	Pulse	FM	For meter		Output item: output frequency (initial setting), permissible load current 2mA, 1440 pulses/s at 60Hz
			Open collector output		Select one e.g. output frequency from monitor items.*2 The output signal is proportional to the magnitude of the corresponding monitoring item.
Analog	AM	Analog signal output	Signals can be output from the open collector terminals by setting Pr.291. (maximum output pulse: 50kpulses/s)		
			Output item: output frequency (initial setting), output signal 0 to 10VDC, permissible load current 1mA(load impedance 10kΩ or more), resolution 8 bit		
Communication	—		PU connector With the PU connector, communication can be made through RS-485. (1:1 connection only) · Conforming standard: EIA-485(RS-485) · Communication speed: 4800 to 38400bps · Transmission format: Multi-drop link · Overall extension: 500m		
	RS-485 terminals	TXD+, TXD-	Inverter transmission terminal With the RS-485 terminals, communication can be made through RS-485. · Conforming standard: EIA-485(RS-485) · Communication speed: 300 to 38400bps · Transmission format: Multi-drop link · Overall extension: 500m		
		RXD+, RXD-	Inverter reception terminal		
		SG	Earth (Ground)		
—		USB connector The FR Configurator can be operated by connecting the inverter to the personal computer through USB. · Interface: conforms to USB1.1 · Connector: USB series B connector · Transfer rate: FS transfer (12Mbps)			

CAUTION

- The inverter will be damaged if power is applied to the inverter output terminals (U, V, W). Never perform such wiring.
- indicates that terminal functions can be selected from Pr.178 to Pr.196 (I/O terminal function selection).
- Terminal names and terminal functions are those of the factory set.
- *1 Low indicates that the open collector output transistor is on (conducts). High indicates that the transistor is off (does not conduct).
- *2 Not output during inverter reset.

- Features
- Peripheral Devices
- Standard Specifications
- Outline Dimension Drawings
- Terminal Connection Diagram Terminal Specification Explanation
- Operation Panel
- Parameter List
- Explanations of Parameters
- Protective Functions
- Options
- Instructions
- Motor
- Compatibility
- Warranty
- Inquiry

Wiring example

Standard motor with encoder (SF-JR), 5V differential line driver (speed control)

Sink logic

⊙ Main circuit terminal

○ Control circuit terminal

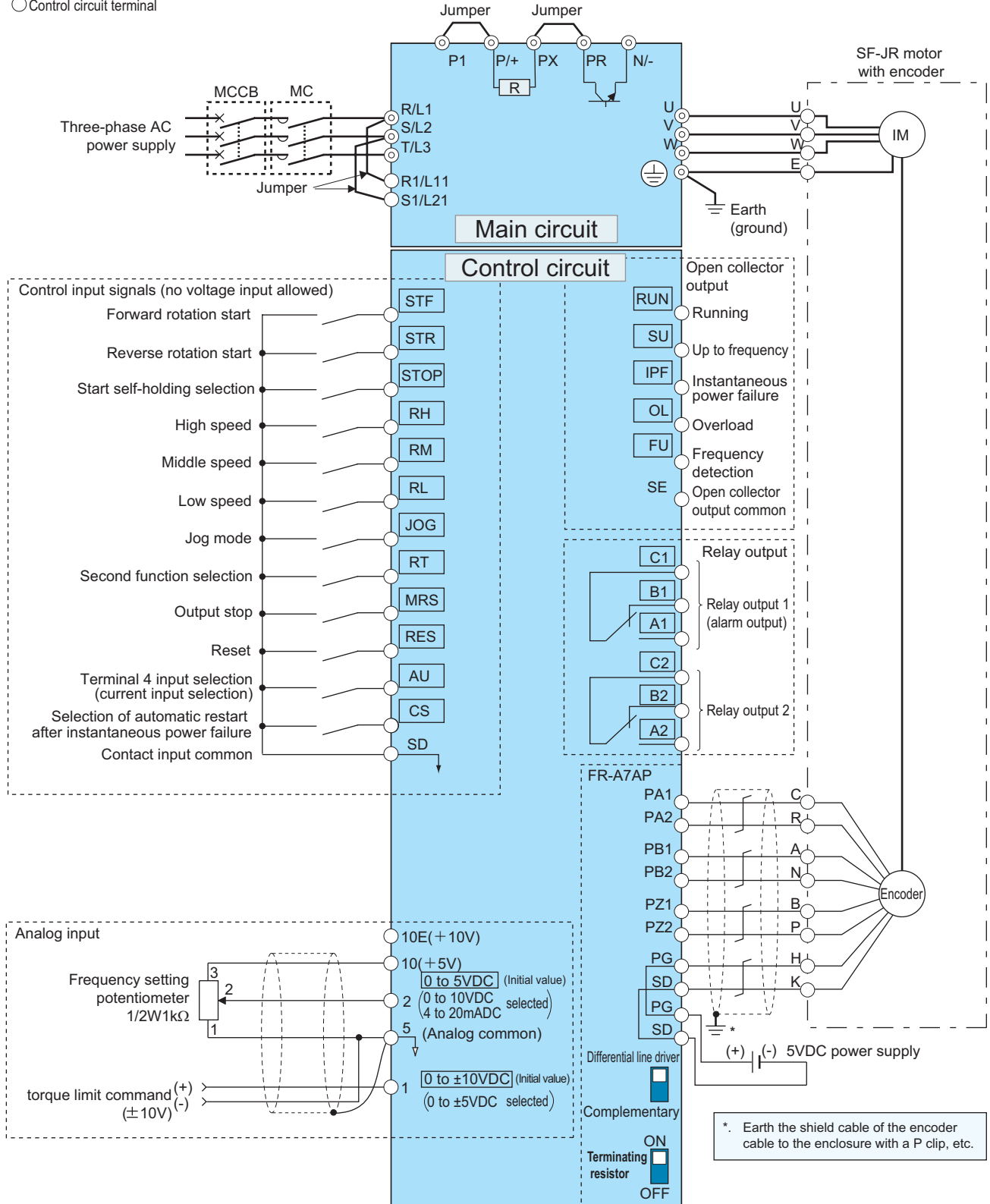

Vector control dedicated motor (SF-V5RU), 12V complementary

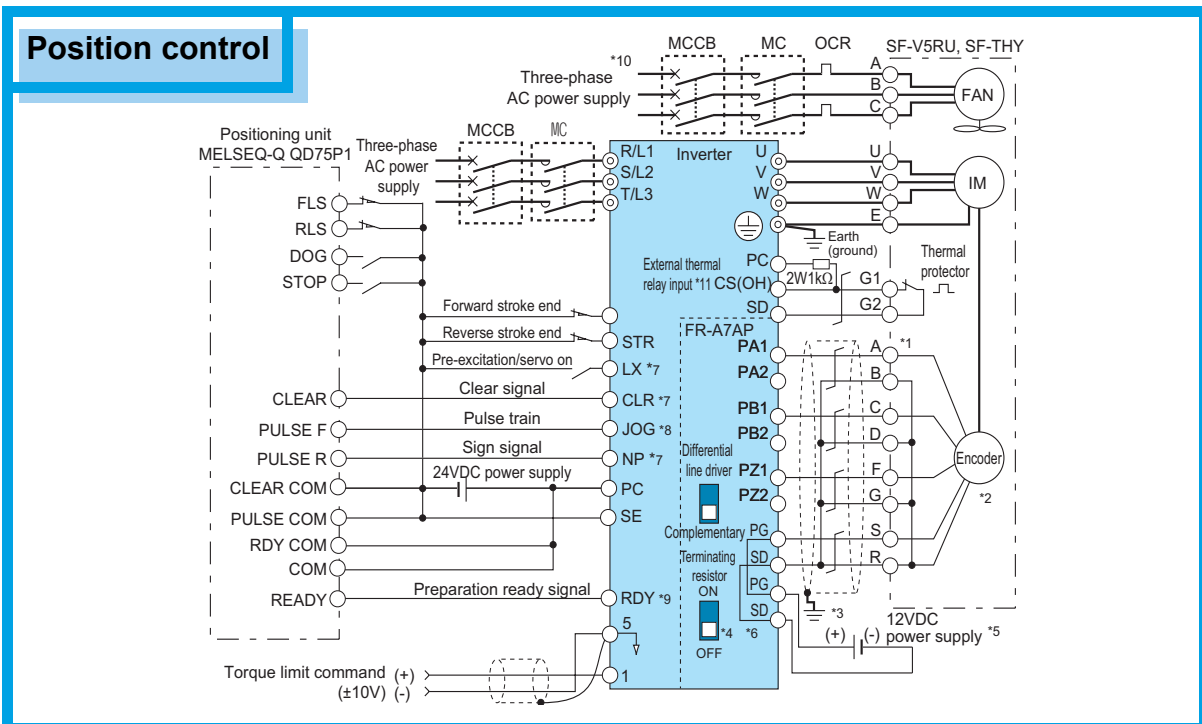
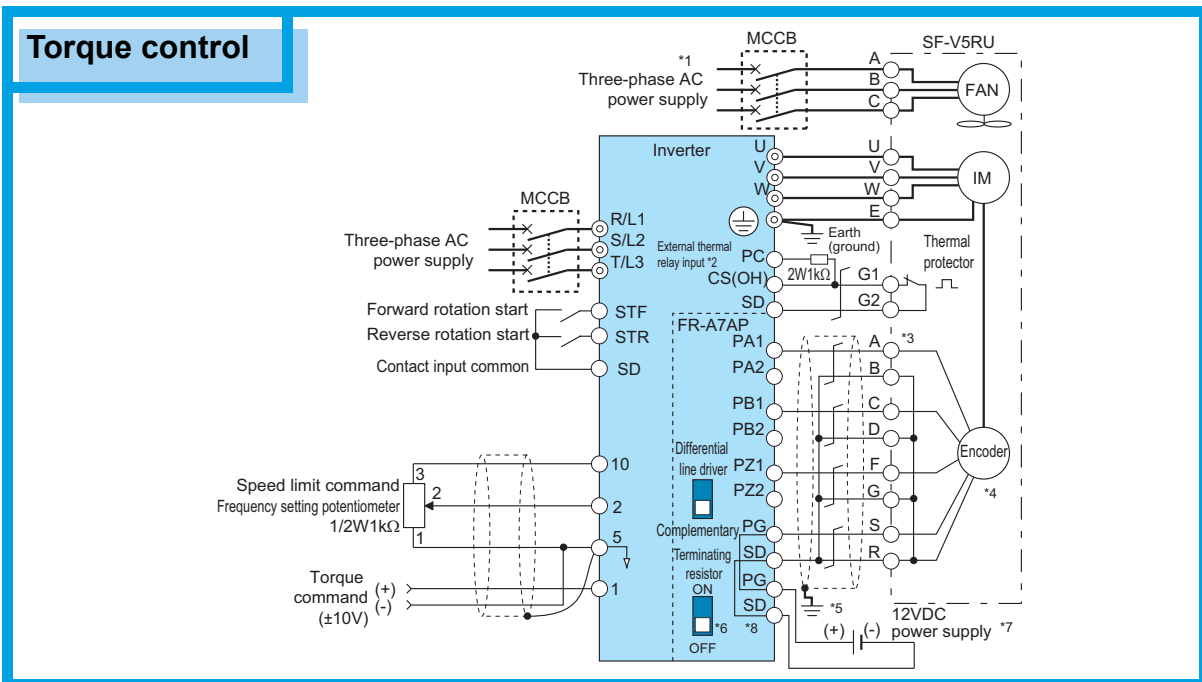

*1 For the fan of the 7.5kW or less dedicated motor, the power supply is single phase (200V/50Hz, 200 to 230V/60Hz).

*2 Assign OH (external thermal input) signal to the terminal CS. (Set "7" in Pr. 186.)
Connect a 2W1kΩ resistor between the terminal PC and CS (CH). Install the resistor pushing it against the bottom part of the terminal block so as to avoid a contact with other cables.
Refer to the inverter manual for details of Pr. 186 CS terminal function selection.

*3 The pin number differs according to the encoder used.
Speed control, torque control and position control by pulse train input are properly performed even without connecting Z phase.

*4 Connect the encoder so that there is no looseness between the motor and motor shaft. Speed ratio should be 1:1.

*5 Earth the shield cable of the encoder cable to the enclosure with a P clip, etc.

*6 For the complementary, set the switch to off position.

*7 A separate power supply of 5V/12V/15V/24V is necessary according to the encoder power specification.

*8 For terminal compatibility of the FR-JCBL, FR-V5CBL and FR-A7AP, refer to the inverter manual or the instruction manual of the FR-A7AP.

*9 Assign the function using Pr.178 to Pr.184, Pr.187 to Pr.189 (input terminal function selection).

*10 When position control is selected, terminal JOG function is made invalid and conditional position pulse train input terminal becomes valid.

*11 Assign the function using Pr.190 to Pr.194 (output terminal function selection).

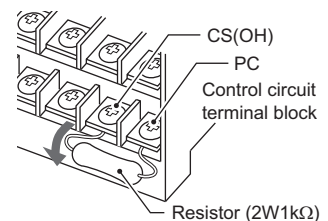

- Features
- Peripheral Devices
- Standard Specifications
- Outline Dimension Drawings
- Terminal Connection Diagram Terminal Specification Explanation
- Operation Panel
- Parameter List
- Explanations of Parameters
- Protective Functions
- Options
- Instructions
- Motor
- Compatibility
- Warranty
- Inquiry

Operation Panel (FR-DU07)

Operation mode indication

PU: Lit to indicate PU operation mode.
 EXT: Lit to indicate External operation mode.
 NET: Lit to indicate Network operation mode.

Unit indication

· Hz: Lit to indicate frequency.
 · A: Lit to indicate current.
 · V: Lit to indicate voltage.
 (Flicker when the set frequency monitor is displayed.)

Rotation direction indication

FWD: Lit during forward rotation
 REV: Lit during reverse rotation
 On: Forward/reverse operation
 Flickering: When the frequency command is not given even if the forward/reverse command is given. When the MRS signal is input.

Monitor indication

Lit to indicate monitoring mode.

Monitor(4-digit LED)

Shows the frequency, parameter number, etc.

No function

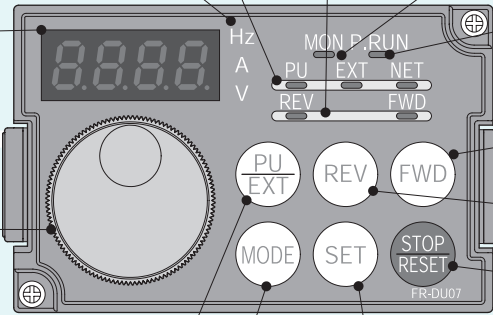

Setting dial

(Setting dial: Mitsubishi inverter dial)
 Used to change the frequency setting and parameter values.

FWD Start command forward rotation
REV Start command reverse rotation

STOP RESET Stop operation
 Used to stop Run command. Fault can be reset when protective function is activated (fault).

SET Used to set each setting.
 If pressed during operation, monitor changes as below;

```

    Running frequency → Output current → Output voltage *
    
```

* Energy saving monitor is displayed when the energy saving monitor of Pr. 52 is set.

MODE Mode switchover
 Used to change each setting mode.

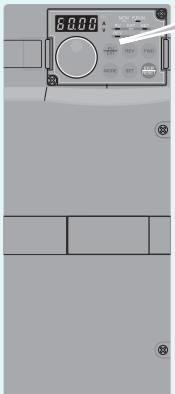

PU EXT Operation mode switchover
 Used to switch between the PU and External operation mode. When using the External operation mode (operation using a separately connected frequency setting potentiometer and start signal), press this key to light up the EXT indication. (Change the Pr. 79 value to use the combined mode.)
 PU: PU operation mode
 EXT: External operation mode

Basic operation

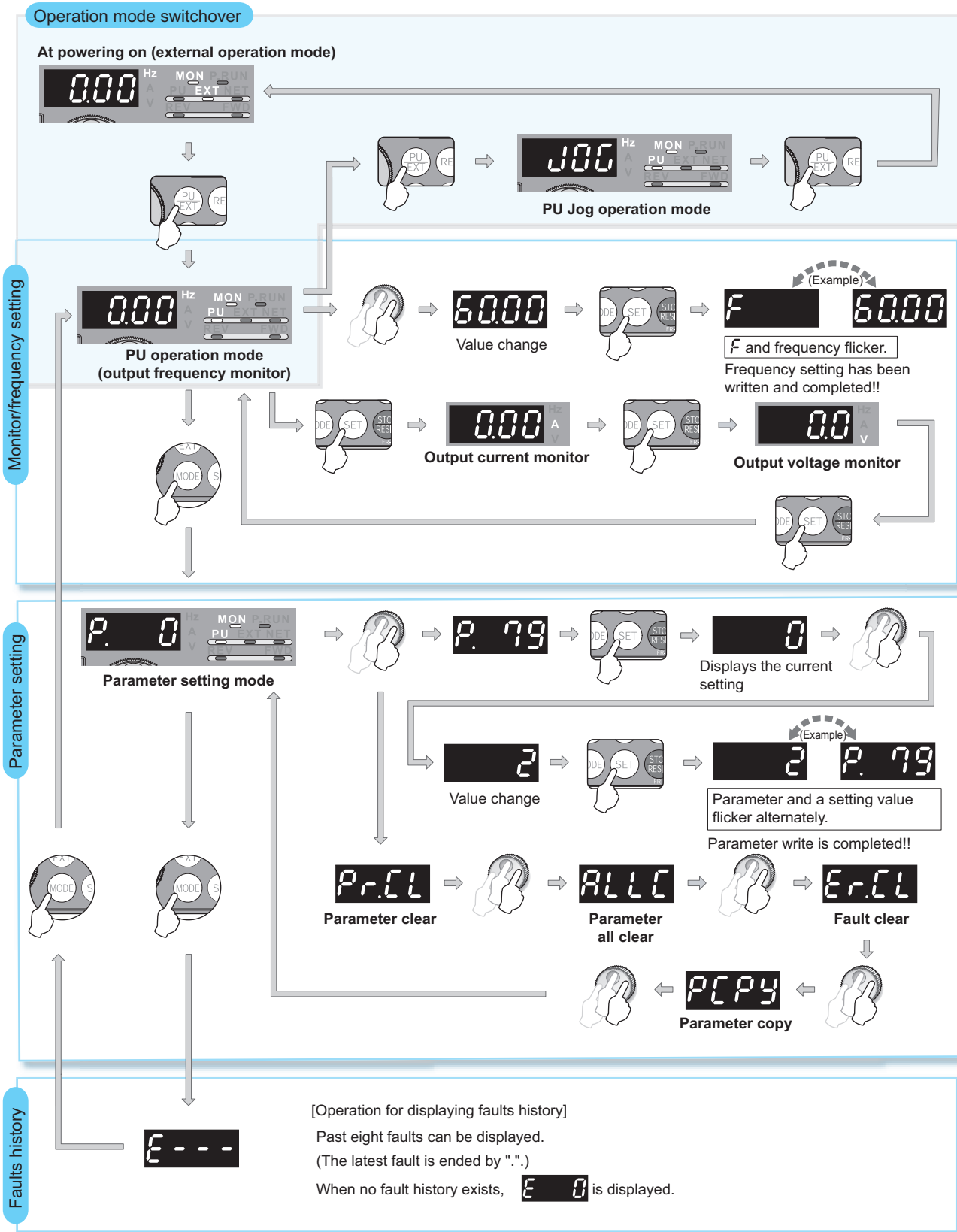

- Features
- Peripheral Devices
- Standard Specifications
- Outline Dimension Drawings
- Terminal Connection Diagram Terminal Specification Explanation
- Operation Panel
- Parameter List
- Explanations of Parameters
- Protective Functions
- Options
- Instructions
- Motor
- Compatibility
- Warranty
- Inquiry

Parameter List

For simple variable-speed operation of the inverter, the initial setting of the parameters may be used as they are. Set the necessary parameters to meet the load and operational specifications. Parameter setting, change and check can be made from the operation panel (FR-DU07). For details of parameters, refer to the instruction manual.

REMARKS

- ◎ indicates simple mode parameters. (initially set to extended mode)
- The shaded parameters in the table allow its setting to be changed during operation even if "0" (initial value) is set in Pr. 77 Parameter write selection.

Function	Parameter	Name	Setting Range	Minimum Setting Increments	Initial Value	Refer to Page	Customer Setting
Basic functions	◎ 0	Torque boost	0 to 30%	0.1%	6/4/3/2/1% *1	42	
	◎ 1	Maximum frequency	0 to 120Hz	0.01Hz	120/60Hz *2	42	
	◎ 2	Minimum frequency	0 to 120Hz	0.01Hz	0Hz	42	
	◎ 3	Base frequency	0 to 400Hz	0.01Hz	60Hz	42	
	◎ 4	Multi-speed setting (high speed)	0 to 400Hz	0.01Hz	60Hz	42	
	◎ 5	Multi-speed setting (middle speed)	0 to 400Hz	0.01Hz	30Hz	42	
	◎ 6	Multi-speed setting (low speed)	0 to 400Hz	0.01Hz	10Hz	42	
	◎ 7	Acceleration time	0 to 3600/360s	0.1/0.01s	5/15s *3	43	
	◎ 8	Deceleration time	0 to 3600/360s	0.1/0.01s	5/15s *3	43	
◎ 9	Electronic thermal O/L relay	0 to 500/0 to 3600A *2	0.01/0.1A *2	Rated inverter current	43		
DC injection brake	10	DC injection brake operation frequency	0 to 120Hz, 9999	0.01Hz	3Hz	43	
	11	DC injection brake operation time	0 to 10s, 8888	0.1s	0.5s	43	
	12	DC injection brake operation voltage	0 to 30%	0.1%	4/2/1%*4	43	
—	13	Starting frequency	0 to 60Hz	0.01Hz	0.5Hz	43	
—	14	Load pattern selection	0 to 5	1	0	44	
Jog operation	15	Jog frequency	0 to 400Hz	0.01Hz	5Hz	44	
	16	Jog acceleration/deceleration time	0 to 3600/360s	0.1/0.01s	0.5s	44	
—	17	MRS input selection	0, 2, 4	1	0	44	
—	18	High speed maximum frequency	120 to 400Hz	0.01Hz	120/60Hz *2	42	
—	19	Base frequency voltage	0 to 1000V, 8888, 9999	0.1V	9999	42	
Acceleration/ deceleration times	20	Acceleration/deceleration reference frequency	1 to 400Hz	0.01Hz	60Hz	43	
	21	Acceleration/deceleration time increments	0, 1	1	0	43	
Stall prevention	22	Stall prevention operation level (torque limit level)	0 to 400%	0.1%	150%	44, 45	
	23	Stall prevention operation level compensation factor at double speed	0 to 200%, 9999	0.1%	9999	44	
Multi-speed setting	24 to 27	Multi-speed setting(4 speed to 7 speed)	0 to 400Hz, 9999	0.01Hz	9999	42	
	28	Multi-speed input compensation selection	0, 1	1	0	45	
—	29	Acceleration/deceleration pattern selection	0 to 5	1	0	46	
—	30	Regenerative function selection	0, 1, 2, 10, 11, 20, 21	1	0	46	
Frequency jump	31	Frequency jump 1A	0 to 400Hz, 9999	0.01Hz	9999	47	
	32	Frequency jump 1B	0 to 400Hz, 9999	0.01Hz	9999	47	
	33	Frequency jump 2A	0 to 400Hz, 9999	0.01Hz	9999	47	
	34	Frequency jump 2B	0 to 400Hz, 9999	0.01Hz	9999	47	
	35	Frequency jump 3A	0 to 400Hz, 9999	0.01Hz	9999	47	
	36	Frequency jump 3B	0 to 400Hz, 9999	0.01Hz	9999	47	
—	37	Speed display	0, 1 to 9998	1	0	47	
Frequency detection	41	Up-to-frequency sensitivity	0 to 100%	0.1%	10%	47	
	42	Output frequency detection	0 to 400Hz	0.01Hz	6Hz	47	
	43	Output frequency detection for reverse rotation	0 to 400Hz, 9999	0.01Hz	9999	47	

Function	Parameter	Name	Setting Range	Minimum Setting Increments	Initial Value	Refer to Page	Customer Setting
Second functions	44	Second acceleration/deceleration time	0 to 3600/360s	0.1/0.01s	5s	43	
	45	Second deceleration time	0 to 3600/360s, 9999	0.1/0.01s	9999	43	
	46	Second torque boost	0 to 30%, 9999	0.1%	9999	42	
	47	Second V/F (base frequency)	0 to 400Hz, 9999	0.01Hz	9999	42	
	48	Second stall prevention operation current	0 to 220%	0.1%	150%	44	
	49	Second stall prevention operation frequency	0 to 400Hz, 9999	0.01Hz	0Hz	44	
	50	Second output frequency detection	0 to 400Hz	0.01Hz	30Hz	47	
Monitor functions	51	Second electronic thermal O/L relay	0 to 500A, 9999/ 0 to 3600A, 9999 *2	0.01/0.1A *2	9999	43	
	52	DU/PU main display data selection	0, 5 to 14, 17 to 20, 22 to 25, 32 to 35, 50 to 57, 100	1	0	48	
	54	FM terminal function selection	1 to 3, 5 to 14, 17, 18, 21, 24, 32 to 34, 50, 52, 53	1	1	48	
	55	Frequency monitoring reference	0 to 400Hz	0.01Hz	60Hz	48	
Automatic restart	56	Current monitoring reference	0 to 500/0 to 3600A *2	0.01/0.1A *2	Rated inverter current	48	
	57	Restart coasting time	0, 0.1 to 5s, 9999/ 0, 0.1 to 30s, 9999 *2	0.1s	9999	49	
	58	Restart cushion time	0 to 60s	0.1s	1s	49	
—	59	Remote function selection	0, 1, 2, 3	1	0	50	
—	60	Energy saving control selection	0, 4	1	0	50	
Automatic acceleration/ deceleration	61	Reference current	0 to 500A, 9999/ 0 to 3600A, 9999 *2	0.01A/0.1A *2	9999	50	
	62	Reference value at acceleration	0 to 220%, 9999	0.1%	9999	50	
	63	Reference value at deceleration	0 to 220%, 9999	0.1%	9999	50	
—	64	Starting frequency for elevator mode	0 to 10Hz, 9999	0.01Hz	9999	50	
—	65	Retry selection	0 to 5	1	0	51	
—	66	Stall prevention operation reduction starting frequency	0 to 400Hz	0.01Hz	60Hz	44	
Retry	67	Number of retries at fault occurrence	0 to 10, 101 to 110	1	0	51	
	68	Retry waiting time	0 to 10s	0.1s	1s	51	
	69	Retry count display erase	0	1	0	51	
—	70	Special regenerative brake duty	0 to 30%/0 to 10% *2	0.1%	0%	46	
—	71	Applied motor	0 to 8, 13 to 18, 20, 23, 24, 30, 33, 34, 40, 43, 44, 50, 53, 54	1	0	51	
—	72	PWM frequency selection	0 to 15/0 to 6, 25 *2	1	2	52	
—	73	Analog input selection	0 to 7, 10 to 17	1	1	52	
—	74	Input filter time constant	0 to 8	1	1	52	
—	75	Reset selection/disconnected PU detection/PU stop selection	0 to 3, 14 to 17	1	14	53	
—	76	Fault code output selection	0, 1, 2	1	0	53	
—	77	Parameter write selection	0, 1, 2	1	0	53	
—	78	Reverse rotation prevention selection	0, 1, 2	1	0	53	
—	© 79	Operation mode selection	0, 1, 2, 3, 4, 6, 7	1	0	54	

- Features
- Peripheral Devices
- Standard Specifications
- Outline Dimension Drawings
- Terminal Connection Diagram Terminal Specification Explanation
- Operation Panel
- Parameter List
- Explanations of Parameters
- Protective Functions
- Options
- Instructions
- Motor
- Compatibility
- Warranty
- Inquiry

Function	Parameter	Name	Setting Range	Minimum Setting Increments	Initial Value	Refer to Page	Customer Setting
Motor constants	80	Motor capacity	0.4 to 55kW, 9999/ 0 to 3600kW, 9999 *2	0.01/0.1kW *2	9999	55	
	81	Number of motor poles	2, 4, 6, 8, 10, 12, 14, 16, 18, 20, 9999	1	9999	55	
	82	Motor excitation current	0 to 500A, 9999/ 0 to 3600A, 9999 *2	0.01/0.1A *2	9999	55	
	83	Rated motor voltage	0 to 1000V	0.1V	200/400V *5	55	
	84	Rated motor frequency	10 to 120Hz	0.01Hz	60Hz	55	
	89	Speed control gain (magnetic flux vector)	0 to 200%, 9999	0.1%	9999	55	
	90	Motor constant (R1)	0 to 50Ω, 9999/ 0 to 400mΩ, 9999 *2	0.001Ω/ 0.01mΩ *2	9999	55	
	91	Motor constant (R2)	0 to 50Ω, 9999/ 0 to 400mΩ, 9999 *2	0.001Ω/ 0.01mΩ *2	9999	55	
	92	Motor constant (L1)	0 to 50Ω (0 to 1000mH), 9999/ 0 to 3600mΩ (0 to 400mH), 9999 *2	0.001Ω (0.1mH)/ 0.01mΩ(0.01mH) *2	9999	55	
	93	Motor constant (L2)	0 to 50Ω (0 to 1000mH), 9999/ 0 to 3600mΩ (0 to 400mH), 9999 *2	0.001Ω (0.1mH)/ 0.01mΩ(0.01mH) *2	9999	55	
	94	Motor constant (X)	0 to 500Ω (0 to 100%), 9999/ 0 to 100Ω (0 to 100%), 9999 *2	0.01Ω (0.1%)/ 0.01Ω (0.01%) *2	9999	55	
	95	Online auto tuning selection	0 to 2	1	0	56	
	96	Auto tuning setting/status	0, 1, 101	1	0	55	
Adjustable 5 points V/F	100	V/F1(first frequency)	0 to 400Hz, 9999	0.01Hz	9999	56	
	101	V/F1(first frequency voltage)	0 to 1,000V	0.1V	0V	56	
	102	V/F2(second frequency)	0 to 400Hz, 9999	0.01Hz	9999	56	
	103	V/F2(second frequency voltage)	0 to 1,000V	0.1V	0V	56	
	104	V/F3(third frequency)	0 to 400Hz, 9999	0.01Hz	9999	56	
	105	V/F3(third frequency voltage)	0 to 1,000V	0.1V	0V	56	
	106	V/F4(fourth frequency)	0 to 400Hz, 9999	0.01Hz	9999	56	
	107	V/F4(fourth frequency voltage)	0 to 1,000V	0.1V	0V	56	
	108	V/F5(fifth frequency)	0 to 400Hz, 9999	0.01Hz	9999	56	
109	V/F5(fifth frequency voltage)	0 to 1,000V	0.1V	0V	56		
Third functions	110	Third acceleration/deceleration time	0 to 3600/360s, 9999	0.1/0.01s	9999	43	
	111	Third deceleration time	0 to 3600/360s, 9999	0.1/0.01s	9999	43	
	112	Third torque boost	0 to 30%, 9999	0.1%	9999	42	
	113	Third V/F (base frequency)	0 to 400Hz, 9999	0.01Hz	9999	42	
	114	Third stall prevention operation current	0 to 220%	0.1%	150%	44	
	115	Third stall prevention operation frequency	0 to 400Hz	0.01Hz	0	44	
	116	Third output frequency detection	0 to 400Hz	0.01Hz	60Hz	47	
PU connector communication	117	PU communication station number	0 to 31	1	0	56	
	118	PU communication speed	48, 96, 192, 384	1	192	56	
	119	PU communication stop bit length	0, 1, 10, 11	1	1	56	
	120	PU communication parity check	0, 1, 2	1	2	56	
	121	Number of PU communication retries	0 to 10, 9999	1	1	56	
	122	PU communication check time interval	0, 0.1 to 999.8s, 9999	0.1s	9999	56	
	123	PU communication waiting time setting	0 to 150ms, 9999	1	9999	56	
	124	PU communication CR/LF selection	0, 1, 2	1	1	56	
—	⊙ 125	Terminal 2 frequency setting gain frequency	0 to 400Hz	0.01Hz	60Hz	57	
—	⊙ 126	Terminal 4 frequency setting gain frequency	0 to 400Hz	0.01Hz	60Hz	57	

Function	Parameter	Name	Setting Range	Minimum Setting Increments	Initial Value	Refer to Page	Customer Setting
PID operation	127	PID control automatic switchover frequency	0 to 400Hz, 9999	0.01Hz	9999	58	
	128	PID action selection	10, 11, 20, 21, 50, 51, 60, 61	1	10	58	
	129	PID proportional band	0.1 to 1000%, 9999	0.1%	100%	58	
	130	PID integral time	0.1 to 3600s, 9999	0.1s	1s	58	
	131	PID upper limit	0 to 100%, 9999	0.1%	9999	58	
	132	PID lower limit	0 to 100%, 9999	0.1%	9999	58	
	133	PID action set point	0 to 100%, 9999	0.01%	9999	58	
	134	PID differential time	0.01 to 10.00s, 9999	0.01s	9999	58	
Bypass	135	Electronic bypass sequence selection	0, 1	1	0	58	
	136	MC switchover interlock time	0 to 100s	0.1s	1s	58	
	137	Start waiting time	0 to 100s	0.1s	0.5s	58	
	138	Bypass selection at a fault	0, 1	1	0	58	
	139	Automatic switchover frequency from inverter to bypass operation	0 to 60Hz, 9999	0.01Hz	9999	58	
Backlash measures	140	Backlash acceleration stopping frequency	0 to 400Hz	0.01Hz	1Hz	46	
	141	Backlash acceleration stopping time	0 to 360s	0.1s	0.5s	46	
	142	Backlash deceleration stopping frequency	0 to 400Hz	0.01Hz	1Hz	46	
	143	Backlash deceleration stopping time	0 to 360s	0.1s	0.5s	46	
—	144	Speed setting switchover	0, 2, 4, 6, 8, 10, 102, 104, 106, 108, 110	1	4	47	
PU	145	PU display language selection	0 to 7	1	0	58	
Current detection	148	Stall prevention level at 0V input	0 to 220%	0.1%	150%	44	
	149	Stall prevention level at 10V input	0 to 220%	0.1%	200%	44	
	150	Output current detection level	0 to 220%	0.1%	150%	58	
	151	Output current detection signal delay time	0 to 10s	0.1s	0s	58	
	152	Zero current detection level	0 to 220%	0.1%	5%	58	
	153	Zero current detection time	0 to 1s	0.01s	0.5s	58	
—	154	Voltage reduction selection during stall prevention operation	0, 1	1	1	44	
—	155	RT signal function validity condition selection	0, 10	1	0	59	
—	156	Stall prevention operation selection	0 to 31, 100, 101	1	0	44	
—	157	OL signal output timer	0 to 25s, 9999	0.1s	0s	44	
—	158	AM terminal function selection	1 to 3, 5 to 14, 17, 18, 21, 24, 32 to 34, 50, 52, 53	1	1	48	
—	159	Automatic switchover frequency range from bypass to inverter operation	0 to 10Hz, 9999	0.01Hz	9999	58	
—	Ⓢ 160	User group read selection	0, 1, 9999	1	0	59	
—	161	Frequency setting/key lock operation selection	0, 1, 10, 11	1	0	59	
Automatic restart functions	162	Automatic restart after instantaneous power failure selection	0, 1, 2, 10, 11, 12	1	0	49	
	163	First cushion time for restart	0 to 20s	0.1s	0s	49	
	164	First cushion voltage for restart	0 to 100%	0.1%	0%	49	
	165	Stall prevention operation level for restart	0 to 220%	0.1%	150%	49	
Current detection	166	Output current detection signal retention time	0 to 10s, 9999	0.1s	0.1s	58	
	167	Output current detection operation selection	0, 1	1	0	58	

Features

Peripheral Devices

Standard Specifications

Outline Dimension Drawings

Terminal Connection Diagram Terminal Specification Explanation

Operation Panel

Parameter List

Explanations of Parameters

Protective Functions

Options

Instructions

Motor

Compatibility

Warranty

Inquiry

Function	Parameter	Name	Setting Range	Minimum Setting Increments	Initial Value	Refer to Page	Customer Setting
—	168	Parameter for manufacturer setting. Do not set.					
—	169						
Cumulative monitor clear	170	Watt-hour meter clear	0, 10, 9999	1	9999	48	
	171	Operation hour meter clear	0, 9999	1	9999	48	
User group	172	User group registered display/batch clear	9999, (0 to 16)	1	0	59	
	173	User group registration	0 to 999, 9999	1	9999	59	
	174	User group clear	0 to 999, 9999	1	9999	59	
Input terminal function assignment	178	STF terminal function selection	0 to 20, 22 to 28, 42 to 44, 60, 62, 64 to 71, 74, 9999	1	60	60	
	179	STR terminal function selection	0 to 20, 22 to 28, 42 to 44, 61, 62, 64 to 71, 74, 9999	1	61	60	
	180	RL terminal function selection	0 to 20, 22 to 28, 42 to 44, 62, 64 to 71, 74, 9999	1	0	60	
	181	RM terminal function selection		1	1	60	
	182	RH terminal function selection		1	2	60	
	183	RT terminal function selection		1	3	60	
	184	AU terminal function selection		1	4	60	
	185	JOG terminal function selection	0 to 20, 22 to 28, 42 to 44, 62, 64 to 71, 74, 9999	1	5	60	
	186	CS terminal function selection		1	6	60	
	187	MRS terminal function selection		1	24	60	
	188	STOP terminal function selection		1	25	60	
189	RES terminal function selection	1		62	60		
Output terminal function assignment	190	RUN terminal function selection	0 to 8, 10 to 20, 25 to 28, 30 to 36, 39, 41 to 47, 64, 70, 84, 85, 90 to 99, 100 to 108, 110 to 116, 120, 125 to 128, 130 to 136, 139, 141 to 147, 164, 170, 184, 185, 190 to 199, 9999	1	0	60	
	191	SU terminal function selection		1	1	60	
	192	IPF terminal function selection		1	2	60	
	193	OL terminal function selection		1	3	60	
	194	FU terminal function selection		1	4	60	
	195	ABC1 terminal function selection	1	99	60		
	196	ABC2 terminal function selection	1	9999	60		
Multi-speed setting	232 to 239	Multi-speed setting(8 speed to 15 speed)	0 to 400Hz, 9999	0.01Hz	9999	42	
—	240	Soft-PWM operation selection	0, 1	1	1	52	
—	241	Analog input display unit switchover	0, 1	1	0	57	
—	242	Terminal 1 added compensation amount (terminal 2)	0 to 100%	0.1%	100%	52	
—	243	Terminal 1 added compensation amount (terminal 4)	0 to 100%	0.1%	75%	52	
—	244	Cooling fan operation selection	0, 1	1	1	61	

Function	Parameter	Name	Setting Range	Minimum Setting Increments	Initial Value	Refer to Page	Customer Setting	
Slip compensation	245	Rated slip	0 to 50%, 9999	0.01%	9999	61		
	246	Slip compensation time constant	0.01 to 10s	0.01s	0.5s	61		
	247	Constant-power range slip compensation selection	0, 9999	1	9999	61		
—	250	Stop selection	0 to 100s, 1000 to 1100s 8888, 9999	0.1s	9999	61		
—	251	Output phase failure protection selection	0, 1	1	1	61		
Frequency compensation function	252	Override bias	0 to 200%	0.1%	50%	52		
	253	Override gain	0 to 200%	0.1%	150%	52		
Life check	255	Life alarm status display	(0 to 15)	1	0	61		
	256	Inrush current limit circuit life display	(0 to 100%)	1%	100%	61		
	257	Control circuit capacitor life display	(0 to 100%)	1%	100%	61		
	258	Main circuit capacitor life display	(0 to 100%)	1%	100%	61		
	259	Main circuit capacitor life measuring	0, 1	1	0	61		
Power failure stop	261	Power failure stop selection	0, 1, 2, 11, 12	1	0	62		
	262	Subtracted frequency at deceleration start	0 to 20Hz	0.01Hz	3Hz	62		
	263	Subtraction starting frequency	0 to 120Hz, 9999	0.01Hz	60Hz	62		
	264	Power-failure deceleration time 1	0 to 3600/360s	0.1/0.01s	5s	62		
	265	Power-failure deceleration time 2	0 to 3600s/360s, 9999	0.1/0.01s	9999	62		
	266	Power failure deceleration time switchover frequency	0 to 400Hz	0.01Hz	60Hz	62		
—	267	Terminal 4 input selection	0, 1, 2	1	0	52		
—	268	Monitor decimal digits selection	0, 1, 9999	1	9999	48		
—	269	Parameter for manufacturer setting. Do not set.						
—	270	Stop-on contact/load torque high-speed frequency control selection	0, 1, 2, 3	1	0	63		
Load torque high speed frequency control	271	High-speed setting maximum current	0 to 220%	0.1%	50%	63		
	272	Middle-speed setting minimum current	0 to 220%	0.1%	100%	63		
	273	Current averaging range	0 to 400Hz, 9999	0.01Hz	9999	63		
	274	Current averaging filter time constant	1 to 4000	1	16	63		
Stop-on contact control	275	Stop-on contact excitation current low-speed multiplying factor	0 to 1000%, 9999	0.1%	9999	63		
	276	PWM carrier frequency at stop-on contact	0 to 9, 9999/ 0 to 4, 9999 *2	1	9999	63		

- Features
- Peripheral Devices
- Standard Specifications
- Outline Dimension Drawings
- Terminal Connection Diagram Terminal Specification Explanation
- Operation Panel
- Parameter List
- Explanations of Parameters
- Protective Functions
- Options
- Instructions
- Motor
- Compatibility
- Warranty
- Inquiry

Function	Parameter	Name	Setting Range	Minimum Setting Increments	Initial Value	Refer to Page	Customer Setting
Brake sequence function	278	Brake opening frequency	0 to 30Hz	0.01Hz	3Hz	64	
	279	Brake opening current	0 to 220%	0.1%	130%	64	
	280	Brake opening current detection time	0 to 2s	0.1s	0.3s	64	
	281	Brake operation time at start	0 to 5s	0.1s	0.3s	64	
	282	Brake operation frequency	0 to 30Hz	0.01Hz	6Hz	64	
	283	Brake operation time at stop	0 to 5s	0.1s	0.3s	64	
	284	Deceleration detection function selection	0, 1	1	0	64	
	285	Overspeed detection frequency (Excessive speed deviation detection frequency)	0 to 30Hz, 9999	0.01Hz	9999	64	
Droop control	286	Droop gain	0 to 100%	0.1%	0%	65	
	287	Droop filter time constant	0 to 1s	0.01s	0.3s	65	
	288	Droop function activation selection	0, 1, 2, 10, 11	1	0	65	
—	291	Pulse train I/O selection	0, 1, 10, 11, 20, 21, 100	1	0	65	
—	292	Automatic acceleration/deceleration	0, 1, 3, 5 to 8, 11	1	0	50	
—	293	Acceleration/deceleration separate selection	0 to 2	1	0	50	
—	294	UV avoidance voltage gain	0 to 200%	0.1%	100%	62	
—	299	Rotation direction detection selection at restarting	0, 1, 9999	1	0	49	
RS-485 communication	331	RS-485 communication station number	0 to 31(0 to 247)	1	0	56	
	332	RS-485 communication speed	3, 6, 12, 24, 48, 96, 192, 384	1	96	56	
	333	RS-485 communication stop bit length	0, 1, 10, 11	1	1	56	
	334	RS-485 communication parity check selection	0, 1, 2	1	2	56	
	335	RS-485 communication retry count	0 to 10, 9999	1	1	56	
	336	RS-485 communication check time interval	0 to 999.8s, 9999	0.1s	0s	56	
	337	RS-485 communication waiting time setting	0 to 150ms, 9999	1	9999	56	
	338	Communication operation command source	0, 1	1	0	65	
	339	Communication speed command source	0, 1, 2	1	0	65	
	340	Communication startup mode selection	0, 1, 2, 10, 12	1	0	54	
	341	RS-485 communication CR/LF selection	0, 1, 2	1	1	56	
	342	Communication EEPROM write selection	0, 1	1	0	56	
343	Communication error count	—	1	0	56		
Orientation control	350 *6	Stop position command selection	0, 1, 9999	1	9999	66	
	351 *6	Orientation speed	0 to 30Hz	0.01Hz	2Hz	66	
	352 *6	Creep speed	0 to 10Hz	0.01Hz	0.5Hz	66	
	353 *6	Creep switchover position	0 to 16383	1	511	66	
	354 *6	Position loop switchover position	0 to 8191	1	96	66	
	355 *6	DC injection brake start position	0 to 255	1	5	66	
	356 *6	Internal stop position command	0 to 16383	1	0	66	
	357 *6	Orientation in-position zone	0 to 255	1	5	66	
	358 *6	Servo torque selection	0 to 13	1	1	66	
	359 *6	Encoder rotation direction	0, 1	1	1	66	
	360 *6	16 bit data selection	0 to 127	1	0	66	
	361 *6	Position shift	0 to 16383	1	0	66	
	362 *6	Orientation position loop gain	0.1 to 100	0.1	1	66	
	363 *6	Completion signal output delay time	0 to 5s	0.1s	0.5s	66	
364 *6	Encoder stop check time	0 to 5s	0.1s	0.5s	66		
365 *6	Orientation limit	0 to 60s, 9999	1s	9999	66		
366 *6	Recheck time	0 to 5s, 9999	0.1s	9999	66		

Function	Parameter	Name	Setting Range	Minimum Setting Increments	Initial Value	Refer to Page	Customer Setting
Encoder feedback	367 *6	Speed feedback range	0 to 400Hz, 9999	0.01Hz	9999	66	
	368 *6	Feedback gain	0 to 100	0.1	1	66	
	369 *6	Number of encoder pulses	0 to 4096	1	1024	66	
	374	Overspeed detection level	0 to 400Hz	0.01Hz	140Hz	66	
	376 *6	Encoder signal loss detection enable/disable selection	0, 1	1	0	66	
S-pattern acceleration/deceleration C	380	Acceleration S-pattern 1	0 to 50%	1%	0	46	
	381	Deceleration S-pattern 1	0 to 50%	1%	0	46	
	382	Acceleration S-pattern 2	0 to 50%	1%	0	46	
	383	Deceleration S-pattern 2	0 to 50%	1%	0	46	
Pulse train input	384	Input pulse division scaling factor	0 to 250	1	0	65	
	385	Frequency for zero input pulse	0 to 400Hz	0.01Hz	0	65	
	386	Frequency for maximum input pulse	0 to 400Hz	0.01Hz	60Hz	65	
Orientation control	393 *6	Orientation selection	0, 1, 2	1	0	66	
	396 *6	Orientation speed gain (P term)	0 to 1000	1	60	66	
	397 *6	Orientation speed integral time	0 to 20s	0.001s	0.333s	66	
	398 *6	Orientation speed gain (D term)	0 to 100	0.1	1	66	
	399 *6	Orientation deceleration ratio	0 to 1000	1	20	66	
Position control	419 *6	Position command source selection	0 to 2	1	0	67	
	420 *6	Command pulse scaling factor numerator	0 to 32767	1	1	67	
	421 *6	Command pulse scaling factor denominator	0 to 32767	1	1	67	
	422 *6	Position loop gain	0 to 150s ⁻¹	1s ⁻¹	25s ⁻¹	68	
	423 *6	Position feed forward gain	0 to 100%	1%	0	68	
	424 *6	Position command acceleration/deceleration time constant	0 to 50s	0.001s	0s	67	
	425 *6	Position feed forward command filter	0 to 5s	0.001s	0s	68	
	426 *6	In-position width	0 to 32767pulse	1	100	68	
	427 *6	Excessive level error	0 to 400K, 9999	1K	40K	68	
	428 *6	Command pulse selection	0 to 5	1	0	67	
	429 *6	Clear signal selection	0, 1	1	1	67	
430 *6	Pulse monitor selection	0 to 5, 9999	1	9999	67		

Features

Peripheral Devices

Standard Specifications

Outline Dimension Drawings

Terminal Connection Diagram Terminal Specification Terminal Explanation

Operation Panel

Parameter List

Explanations of Parameters

Protective Functions

Options

Instructions

Motor

Compatibility

Warranty

Inquiry

Function	Parameter	Name	Setting Range	Minimum Setting Increments	Initial Value	Refer to Page	Customer Setting
Second motor constants	450	Second applied motor	0 to 8, 13 to 18, 20, 23, 24, 30, 33, 34, 40, 43, 44, 50, 53, 54, 9999	1	9999	51	
	451	Second motor control method selection	10, 11, 12, 20, 9999	1	9999	55	
	453	Second motor capacity	0.4 to 55kW, 9999/ 0 to 3600kW, 9999 *2	0.01kW/0.1kW *2	9999	55	
	454	Number of second motor poles	2, 4, 6, 8, 10, 9999	1	9999	55	
	455	Second motor excitation current	0 to 500A, 9999/ 0 to 3600A, 9999 *2	0.01/0.1A *2	9999	55	
	456	Rated second motor voltage	0 to 1000V	0.1V	200/400V *5	55	
	457	Rated second motor frequency	10 to 120Hz	0.01Hz	60Hz	55	
	458	Second motor constant (R1)	0 to 50Ω, 9999/ 0 to 400mΩ, 9999 *2	0.001Ω/ 0.01mΩ *2	9999	55	
	459	Second motor constant (R2)	0 to 50Ω, 9999/ 0 to 400mΩ, 9999 *2	0.001Ω/ 0.01mΩ *2	9999	55	
	460	Second motor constant (L1)	0 to 50Ω (0 to 1000mH), 9999/ 0 to 3600mΩ (0 to 400mH), 9999 *2	0.001Ω (0.1mH)/ 0.01mΩ(0.01mH) *2	9999	55	
	461	Second motor constant (L2)	0 to 50Ω (0 to 1000mH), 9999/ 0 to 3600mΩ (0 to 400mH), 9999 *2	0.001Ω (0.1mH)/ 0.01mΩ(0.01mH) *2	9999	55	
	462	Second motor constant (X)	0 to 500Ω (0 to 100%), 9999/ 0 to 100Ω (0 to 100%), 9999 *2	0.01Ω (0.1%)/ 0.01Ω (0.01%) *2	9999	55	
	463	Second motor auto tuning setting/ status	0, 1, 101	1	0	55	
Simple position feed function	464 *6	Digital position control sudden stop deceleration time	0 to 360.0s	0.1s	0	67	
	465 *6	First position feed amount lower 4 digits	0 to 9999	1	0	67	
	466 *6	First position feed amount upper 4 digits	0 to 9999	1	0	67	
	467 *6	Second position feed amount lower 4 digits	0 to 9999	1	0	67	
	468 *6	Second position feed amount upper 4 digits	0 to 9999	1	0	67	
	469 *6	Third position feed amount lower 4 digits	0 to 9999	1	0	67	
	470 *6	Third position feed amount upper 4 digits	0 to 9999	1	0	67	
	471 *6	Fourth position feed amount lower 4 digits	0 to 9999	1	0	67	
	472 *6	Fourth position feed amount upper 4 digits	0 to 9999	1	0	67	
	473 *6	Fifth position feed amount lower 4 digits	0 to 9999	1	0	67	
	474 *6	Fifth position feed amount upper 4 digits	0 to 9999	1	0	67	
	475 *6	Sixth position feed amount lower 4 digits	0 to 9999	1	0	67	
	476 *6	Sixth position feed amount upper 4 digits	0 to 9999	1	0	67	
	477 *6	Seventh position feed amount lower 4 digits	0 to 9999	1	0	67	
	478 *6	Seventh position feed amount upper 4 digits	0 to 9999	1	0	67	
	479 *6	Eighth position feed amount lower 4 digits	0 to 9999	1	0	67	
	480 *6	Eighth position feed amount upper 4 digits	0 to 9999	1	0	67	
	481 *6	Ninth position feed amount lower 4 digits	0 to 9999	1	0	67	
	482 *6	Ninth position feed amount upper 4 digits	0 to 9999	1	0	67	
	483 *6	Tenth position feed amount lower 4 digits	0 to 9999	1	0	67	
	484 *6	Tenth position feed amount upper 4 digits	0 to 9999	1	0	67	
485 *6	Eleventh position feed amount lower 4 digits	0 to 9999	1	0	67		
486 *6	Eleventh position feed amount upper 4 digits	0 to 9999	1	0	67		
487 *6	Twelfth position feed amount lower 4 digits	0 to 9999	1	0	67		
488 *6	Twelfth position feed amount upper 4 digits	0 to 9999	1	0	67		
489 *6	Thirteenth position feed amount lower 4 digits	0 to 9999	1	0	67		
490 *6	Thirteenth position feed amount upper 4 digits	0 to 9999	1	0	67		
491 *6	Fourteenth position feed amount lower 4 digits	0 to 9999	1	0	67		
492 *6	Fourteenth position feed amount upper 4 digits	0 to 9999	1	0	67		
493 *6	Fifteenth position feed amount lower 4 digits	0 to 9999	1	0	67		
494 *6	Fifteenth position feed amount upper 4 digits	0 to 9999	1	0	67		
Remote output	495	Remote output selection	0, 1, 10, 11	1	0	68	
	496	Remote output data 1	0 to 4095	1	0	68	
	497	Remote output data 2	0 to 4095	1	0	68	

Function	Parameter	Name	Setting Range	Minimum Setting Increments	Initial Value	Refer to Page	Customer Setting
Maintenance	503	Maintenance timer	0 (1 to 9998)	1	0	68	
	504	Maintenance timer alarm output set time	0 to 9998, 9999	1	9999	68	
—	505	Speed setting reference	1 to 120Hz	0.01Hz	60Hz	46	
S-pattern acceleration/ deceleration D	516	S-pattern time at a start of acceleration	0.1 to 2.5s	0.1s	0.1s	46	
	517	S-pattern time at a completion of acceleration	0.1 to 2.5s	0.1s	0.1s	46	
	518	S-pattern time at a start of deceleration	0.1 to 2.5s	0.1s	0.1s	46	
	519	S-pattern time at a completion of deceleration	0.1 to 2.5s	0.1s	0.1s	46	
—	539	Modbus-RTU communication check time interval	0 to 999.8s, 9999	0.1s	9999	56	
USB	547	USB communication station number	0 to 31	1	0	68	
	548	USB communication check time interval	0 to 999.8s, 9999	0.1s	9999	68	
Communication	549	Protocol selection	0, 1	1	0	56	
	550	NET mode operation command source selection	0, 1, 9999	1	9999	65	
	551	PU mode operation command source selection	1, 2, 3	1	2	65	
Current average value monitor	555	Current average time	0.1 to 1.0s	0.1s	1s	69	
	556	Data output mask time	0.0 to 20.0s	0.1s	0s	69	
	557	Current average value monitor signal output reference current	0 to 500/0 to 3600A *2	0.01/0.1A *2	Rated inverter current	69	
—	563	Energization time carrying-over times	(0 to 65535)	1	0	48	
—	564	Operating time carrying-over times	(0 to 65535)	1	0	48	
Second motor constants	569	Second motor speed control gain	0 to 200%, 9999	0.1%	9999	55	
	571	Holding time at a start	0.0 to 10.0s, 9999	0.1s	9999	43	
—	574	Second motor online auto tuning	0, 1	1	0	56	
PID control	575	Output interruption detection time	0 to 3600s, 9999	0.1s	1s	58	
	576	Output interruption detection level	0 to 400Hz	0.01Hz	0Hz	58	
	577	Output interruption cancel level	900 to 1100%	0.1%	1000%	58	
—	611	Acceleration time at a restart	0 to 3600s, 9999	0.1s	5/15s *2	49	
—	665	Regeneration avoidance frequency gain	0 to 200%	0.1%	100%	73	
—	684	Tuning data unit switchover	0, 1	1	0	55	
—	800	Control method selection	0 to 5, 9 to 12, 20	1	20	55	
—	802 *6	Pre-excitation selection	0, 1	1	0	43	
Torque command	803	Constant power range torque characteristic selection	0, 1	1	0	45	
	804	Torque command source selection	0 to 6	1	0	69	
	805	Torque command value (RAM)	600 to 1400%	1%	1000%	69	
	806	Torque command value (RAM,EEPROM)	600 to 1400%	1%	1000%	69	

- Features
- Peripheral Devices
- Standard Specifications
- Outline Dimension Drawings
- Terminal Connection Diagram Terminal Specification Explanation
- Operation Panel
- Parameter List
- Explanations of Parameters
- Protective Functions
- Options
- Instructions
- Motor
- Compatibility
- Warranty
- Inquiry

Function	Parameter	Name	Setting Range	Minimum Setting Increments	Initial Value	Refer to Page	Customer Setting
Speed limit	807	Speed limit selection	0, 1, 2	1	0	70	
	808	Forward rotation speed limit	0 to 120Hz	0.01Hz	60Hz	70	
	809	Reverse rotation speed limit	0 to 120Hz, 9999	0.01Hz	9999	70	
Torque limit	810	Torque limit input method selection	0, 1	1	0	45	
	811	Set resolution switchover	0, 1, 10, 11	1	0	45	
	812	Torque limit level (regeneration)	0 to 400%, 9999	0.1%	9999	45	
	813	Torque limit level (3rd quadrant)	0 to 400%, 9999	0.1%	9999	45	
	814	Torque limit level (4th quadrant)	0 to 400%, 9999	0.1%	9999	45	
	815	Torque limit level 2	0 to 400%, 9999	0.1%	9999	45	
	816	Torque limit level during acceleration	0 to 400%, 9999	0.1%	9999	45	
Easy gain tuning	817	Torque limit level during deceleration	0 to 400%, 9999	0.1%	9999	45	
	818	Easy gain tuning response level setting	1 to 15	1	2	70	
	819	Easy gain tuning selection	0 to 2	1	0	70	
Adjustment function	820	Speed control P gain 1	0 to 1000%	1%	60%	70	
	821	Speed control integral time 1	0 to 20s	0.001s	0.333s	70	
	822	Speed setting filter 1	0 to 5s, 9999	0.001s	9999	52	
	823 *6	Speed detection filter 1	0 to 0.1s	0.001s	0.001s	70	
	824	Torque control P gain 1	0 to 200%	1%	100%	70	
	825	Torque control integral time 1	0 to 500ms	0.1ms	5ms	70	
	826	Torque setting filter 1	0 to 5s, 9999	0.001s	9999	52	
	827	Torque detection filter 1	0 to 0.1s	0.001s	0s	71	
	828	Model speed control gain	0 to 1000%	1%	60%	71	
	830	Speed control P gain 2	0 to 1000%, 9999	1%	9999	70	
	831	Speed control integral time 2	0 to 20s, 9999	0.001s	9999	70	
	832	Speed setting filter 2	0 to 5s, 9999	0.001s	9999	52	
	833 *6	Speed detection filter 2	0 to 0.1s, 9999	0.001s	9999	70	
	834	Torque control P gain 2	0 to 200%, 9999	1%	9999	70	
	835	Torque control integral time 2	0 to 500ms, 9999	0.1ms	9999	70	
836	Torque setting filter 2	0 to 5s, 9999	0.001s	9999	52		
837	Torque detection filter 2	0 to 0.1s, 9999	0.001s	9999	71		
Torque bias	840 *6	Torque bias selection	0 to 3, 9999	1	9999	71	
	841 *6	Torque bias 1	600 to 1400%, 9999	1%	9999	71	
	842 *6	Torque bias 2	600 to 1400%, 9999	1%	9999	71	
	843 *6	Torque bias 3	600 to 1400%, 9999	1%	9999	71	
	844 *6	Torque bias filter	0 to 5s, 9999	0.001s	9999	71	
	845 *6	Torque bias operation time	0 to 5s, 9999	0.01s	9999	71	
	846 *6	Torque bias balance compensation	0 to 10V, 9999	0.1V	9999	71	
	847 *6	Fall-time torque bias terminal 1 bias	0 to 400%, 9999	1%	9999	71	
848 *6	Fall-time torque bias terminal 1 gain	0 to 400%, 9999	1%	9999	71		
Additional function	849	Analog input offset adjustment	0 to 200%	0.1%	100%	52	
	850	Brake operation selection	0, 1	1	0	43	
	853 *6	Speed deviation time	0 to 100s	0.1s	1s	64	
	854	Excitation ratio	0 to 100%	1%	100%	71	
	858	Terminal 4 function assignment	0, 1, 4, 9999	1	0	72	
	859	Torque current	0 to 500A, 9999/ 0 to 3600A, 9999 *2	0.01A/0.1A *2	9999	55	
	860	Second motor torque current	0 to 500A, 9999/ 0 to 3600A, 9999 *2	0.01A/0.1A *2	9999	55	
	862	Notch filter time constant	0 to 60	1	0	72	
	863	Notch filter depth	0, 1, 2, 3	1	0	72	
864	Torque detection	0 to 400%	0.1%	150%	72		
865	Low speed detection	0 to 400Hz	0.01Hz	1.5Hz	47		

Function	Parameter	Name	Setting Range	Minimum Setting Increments	Initial Value	Refer to Page	Customer Setting
Indication function	866	Torque monitoring reference	0 to 400%	0.1%	150%	48	
	867	AM output filter	0 to 5s	0.01s	0.01s	48	
—	868	Terminal 1 function assignment	0 to 6, 9999	1	0	72	
Protective Functions	872	Input phase loss protection selection	0, 1	1	0	61	
	873 *6	Speed limit	0 to 120Hz	0.01Hz	20Hz	72	
	874	OLT level setting	0 to 200%	0.1%	150%	45	
	875	Fault definition	0, 1	1	0	72	
Control system functions	877	Speed feed forward control/model adaptive speed control selection	0, 1, 2	1	0	71	
	878	Speed feed forward filter	0 to 1s	0.01s	0s	71	
	879	Speed feed forward torque limit	0 to 400%	0.1%	150%	71	
	880	Load inertia ratio	0 to 200 times	0.1	7	71	
	881	Speed feed forward gain	0 to 1000%	1%	0%	71	
Regeneration avoidance function	882	Regeneration avoidance operation selection	0, 1, 2	1	0	73	
	883	Regeneration avoidance operation level	300 to 800V	0.1V	380/760VDC *5	73	
	884	Regeneration avoidance at deceleration detection sensitivity	0 to 5	1	0	73	
	885	Regeneration avoidance compensation frequency limit value	0 to 10Hz, 9999	0.01Hz	6Hz	73	
	886	Regeneration avoidance voltage gain	0 to 200%	0.1%	100%	73	
Free parameters	888	Free parameter 1	0 to 9999	1	9999	73	
	889	Free parameter 2	0 to 9999	1	9999	73	
Energy saving monitor	891	Cumulative power monitor digit shifted times	0 to 4, 9999	1	9999	48	
	892	Load factor	30 to 150%	0.1%	100%	73	
	893	Energy saving monitor reference (motor capacity)	0.1 to 55/0 to 3600kW *2	0.01/ 0.1kW *2	Inverter rated capacity	73	
	894	Control selection during commercial power-supply operation	0, 1, 2, 3	1	0	73	
	895	Power saving rate reference value	0, 1, 9999	1	9999	73	
	896	Power unit cost	0 to 500, 9999	0.01	9999	73	
	897	Power saving monitor average time	0, 1 to 1000h, 9999	1h	9999	73	
	898	Power saving cumulative monitor clear	0, 1, 10, 9999	1	9999	73	
	899	Operation time rate (estimated value)	0 to 100%, 9999	0.1%	9999	73	

Features

Peripheral Devices

Standard Specifications

Outline Dimension Drawings

Terminal Connection Diagram
Terminal Specification
Terminal Explanation

Operation Panel

Parameter List

Explanations of Parameters

Protective Functions

Options

Instructions

Motor

Compatibility

Warranty

Inquiry

Function	Parameter	Name	Setting Range	Minimum Setting Increments	Initial Value	Refer to Page	Customer Setting
Calibration parameters	C0 (900)^{*7}	FM terminal calibration	—	—	—	74	
	C1 (901)^{*7}	AM terminal calibration	—	—	—	74	
	C2 (902)^{*7}	Terminal 2 frequency setting bias frequency	0 to 400Hz	0.01Hz	0Hz	57	
	C3 (902)^{*7}	Terminal 2 frequency setting bias	0 to 300%	0.1%	0%	57	
	125 (903)^{*7}	Terminal 2 frequency setting gain frequency	0 to 400Hz	0.01Hz	60Hz	57	
	C4 (903)^{*7}	Terminal 2 frequency setting gain	0 to 300%	0.1%	100%	57	
	C5 (904)^{*7}	Terminal 4 frequency setting bias frequency	0 to 400Hz	0.01Hz	0Hz	57	
	C6 (904)^{*7}	Terminal 4 frequency setting bias	0 to 300%	0.1%	20%	57	
	126 (905)^{*7}	Terminal 4 frequency setting gain frequency	0 to 400Hz	0.01Hz	60Hz	57	
C7 (905)^{*7}	Terminal 4 frequency setting gain	0 to 300%	0.1%	100%	57		
Calibration parameters	C12 (917)^{*7}	Terminal 1 bias frequency (speed)	0 to 400Hz	0.01Hz	0Hz	57	
	C13 (917)^{*7}	Terminal 1 bias (speed)	0 to 300%	0.1%	0%	57	
	C14 (918)^{*7}	Terminal 1 gain frequency (speed)	0 to 400Hz	0.01Hz	60Hz	57	
	C15 (918)^{*7}	Terminal 1 gain (speed)	0 to 300%	0.1%	100%	57	
	C16 (919)^{*7}	Terminal 1 bias command (torque/magnetic flux)	0 to 400%	0.1%	0%	57	
	C17 (919)^{*7}	Terminal 1 bias (torque/magnetic flux)	0 to 300%	0.1%	0%	57	
	C18 (920)^{*7}	Terminal 1 gain command (torque/magnetic flux)	0 to 400%	0.1%	150%	57	
	C19 (920)^{*7}	Terminal 1 gain (torque/magnetic flux)	0 to 300%	0.1%	100%	57	
	C38 (932)^{*7}	Terminal 4 bias command (torque/magnetic flux)	0 to 400%	0.1%	0%	57	
	C39 (932)^{*7}	Terminal 4 bias (torque/magnetic flux)	0 to 300%	0.1%	20%	57	
	C40 (933)^{*7}	Terminal 4 gain command (torque/magnetic flux)	0 to 400%	0.1%	150%	57	
C41 (933)^{*7}	Terminal 4 gain (torque/magnetic flux)	0 to 300%	0.1%	100%	57		
—	989	Parameter copy alarm release	10/100	1	10/100 ^{*2}	74	
PU	990	PU buzzer control	0, 1	1	1	74	
	991	PU contrast adjustment	0 to 63	1	58	74	
Clear parameters	Pr. CL	Parameter clear	0, 1	1	0	74	
	ALLC	All parameter clear	0, 1	1	0	74	
	Er.CL	Faults history clear	0, 1	1	0	74	
	PCPY	Parameter copy	0, 1, 2, 3	1	0	74	

*1 Differ according to capacities.0.4K, 0.75K1.5K to 3.7K5.5K, 7.5K11K to 55K75K or more

*2 Differ according to capacities.

(55K or less/75K or more)

*3 Differ according to capacities.

5s: 7.5K or less

15s: 11K or more

*4 Differ according to capacities.

4%: 7.5K or less

2%: 11K to 55K

1%: 75K or more

*5 Differs according to the voltage class. (200V class/400V class)

*6 Setting can be made only when the FR-A7AP/FR-A7AL is mounted.

*7 The parameter number in parentheses is the one for use with the parameter unit (FR-PU04/FR-PU07).

Explanations of Parameters

The abbreviations in the explanations below are as follows: **V/F** ...V/F control, **Magnetic flux** ...advanced magnetic flux vector control, **Sensorless** ...real sensorless vector control, **Vector** ...vector control
(Parameters without any indication are valid for all control)

Pr. 0, 46, 112

Manual torque boost **V/F**

Pr.0 Torque boost Pr.46 Second torque boost
Pr.112 Third torque boost

- A voltage drop in the low-frequency region can be compensated to improve the motor torque reduction in the low speed range.
- Motor torque in the low-frequency range can be adjusted to the load to increase the starting motor torque.
- Three kinds of starting torque boost can be switched by using terminal RT and X9 signal.
- This function is valid for V/F control only.

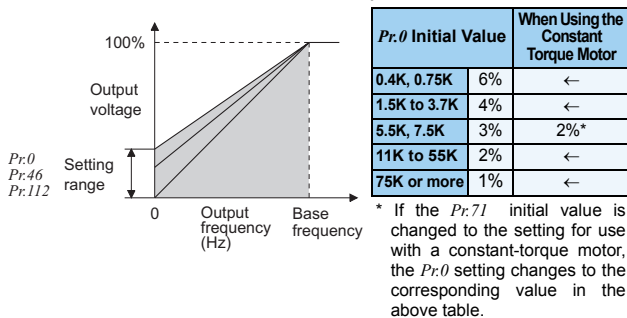

Pr. 1, 2, 18

Maximum/minimum frequency

Pr.1 Maximum frequency Pr.2 Minimum frequency
Pr.18 High speed maximum frequency

- Motor speed can be limited.
- Clamp the upper and lower limits of the output frequency.
- To perform operation above 120Hz (60Hz for the 75K or more), set the maximum output frequency in Pr.18.
- (When Pr.18 is set, Pr.1 is automatically changed to the frequency set in Pr.18. Also, when Pr.1 is set, Pr.18 is automatically changed to the frequency set in Pr.1.
- Pr.18 is valid only under V/F control and advanced magnetic flux vector control.
- The maximum frequency is valid for the speed command obtained from the droop pulses during position control under vector control. The minimum frequency is invalid.

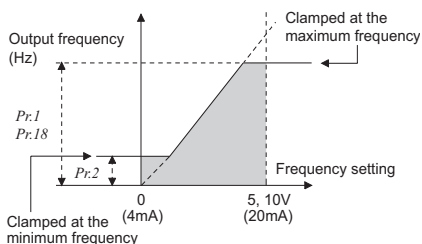

Pr. 3, 19, 47, 113

Base frequency, voltage **V/F**

Pr.3 Base frequency Pr.19 Base frequency voltage
Pr.47 Second V/F (base frequency) Pr.113 Third V/F (base frequency)

- Used to adjust the inverter outputs (voltage, frequency) to the motor rating.
- When running a standard motor, generally set the rated frequency of the motor in Pr.3 Base frequency. When running the motor using commercial power supply-inverter switch-over operation, set Pr.3 to the same value as the power supply frequency.
- When you want to change the base frequency when switching multiple motors with one inverter, etc., use the Pr.47 Second V/F (base frequency) and Pr.113 Third V/F (base frequency).
- Use Pr.19 Base frequency voltage to set the base voltage (e.g. rated motor voltage).
- This function is valid for V/F control only.

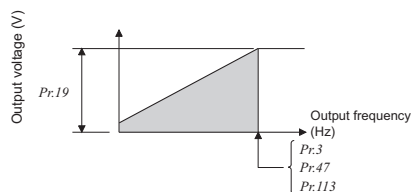

Pr. 4 to 6, 24 to 27, 232 to 239

Multi-speed setting operation

Pr.4 Multi-speed setting (high speed) Pr.5 Multi-speed setting (middle speed)
Pr.6 Multi-speed setting (low speed) Pr.24 Multi-speed setting (speed 4)
Pr.25 Multi-speed setting (speed 5) Pr.26 Multi-speed setting (speed 6)
Pr.27 Multi-speed setting (speed 7) Pr.232 Multi-speed setting (speed 8)
Pr.233 Multi-speed setting (speed 9) Pr.234 Multi-speed setting (speed 10)
Pr.235 Multi-speed setting (speed 11) Pr.236 Multi-speed setting (speed 12)
Pr.237 Multi-speed setting (speed 13) Pr.238 Multi-speed setting (speed 14)
Pr.239 Multi-speed setting (speed 15)

- Can be used to change the preset speed in the parameter with the contact signals.
- Any speed can be selected by merely turning on-off the contact signals (RH, RM, RL, REX signals).
- The inverter operates at frequencies set in Pr.4 when RH signal is on, Pr.5 when RM signal is on and Pr.6 when RL signal is on.
- Frequency from 4 speed to 15 speed can be set according to the combination of the RH, RM, RL and REX signals. Set the running frequencies in Pr.24 to Pr.27, Pr.232 to Pr.239 (In the initial value setting, speed 4 to speed 15 are unavailable)

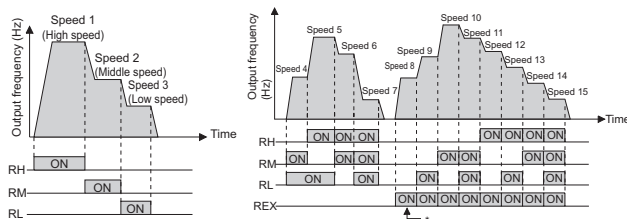

*1 When "9999" is set in Pr.232 Multi-speed setting (speed 8), operation is performed at frequency set in Pr.6 when RH, RM and RL are turned off and REX is turned on.

- Features
- Peripheral Devices
- Standard Specifications
- Outline Dimension Drawings
- Terminal Connection Diagram Terminal Specification Explanation
- Operation Panel
- Parameter List
- Explanations of Parameters
- Protective Functions
- Options
- Instructions
- Motor
- Compatibility
- Warranty
- Inquiry

Pr 7, 8, 20, 21, 44, 45, 110, 111
Acceleration/deceleration time setting

Pr.7 Acceleration time	Pr.8 Deceleration time
Pr.20 Acceleration/deceleration reference frequency	Pr.21 Acceleration/deceleration time increments
Pr.44 Second acceleration/deceleration time	Pr.45 Second deceleration time
Pr.110 Third acceleration/deceleration time	Pr.111 Third deceleration time

Used to set motor acceleration/deceleration time. Set a larger value for a slower speed increase/decrease or a smaller value for a faster speed increase/decrease.

- Use Pr.7 Acceleration time to set the acceleration time taken to reach Pr.20 Acceleration/deceleration reference frequency from 0Hz.
- Use Pr.8 Deceleration time to set the deceleration time taken to reach 0Hz from Pr.20 Acceleration/deceleration reference frequency.

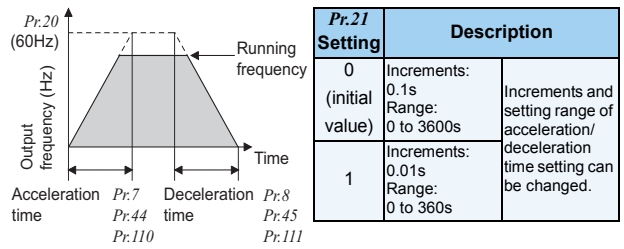

Pr 9, 51
Motor protection from overheat (electronic thermal relay function)

Pr.9 Electronic thermal O/L relay	Pr.51 Second electronic thermal O/L relay
-----------------------------------	---

Set the current of the electronic thermal relay function to protect the motor from overheat. This feature provides the optimum protective characteristics, including reduced motor cooling capability, at low speed.

- Used to detect the motor overload (overheat) and stop the inverter output transistor operation to stop the output.
- Set the rated current [A] of the motor in Pr.9. (When the power supply specification is 200V/220V(400V/440V) 60Hz, set the 1.1 times the rated motor current.)
- Set "0" in Pr.9 to make the electronic thermal relay function invalid when using a motor with an external thermal relay, etc. (Note that the output transistor protection of the inverter functions (E.THT).)
- When using a Mitsubishi constant-torque motor
 - 1) Set any of "1, 13 to 18, 50, 53, 54" in Pr.71. (This provides a 100% continuous torque characteristic in the low-speed range.)
 - 2) Set the rated current of the motor in Pr.9.
- When the RT signal is on, thermal protection is provided based on the Pr.51 setting.

Use this function when running two motors of different rated currents individually by a single inverter. (When running two motors together, use external thermal relays.)

Pr 10 to 12, 802, 850
DC injection brake, zero speed control, servo lock

Pr.10 DC injection brake operation frequency	Pr.11 DC injection brake operation time
Pr.12 DC injection brake operation voltage	Pr.802 Pre-excitation selection
Pr.850 Brake operation selection	

The DC injection brake can be operated at a motor stop to adjust the stop timing and braking torque.

- When "8888" is set in Pr.11, DC brake is applied while X13 signal is on.
- Pr.12 is valid only under V/F control and advanced magnetic flux vector control.

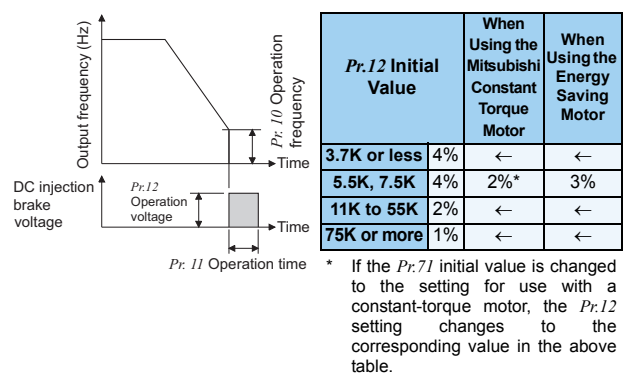

- DC brake (setting "0", initial value) and zero speed control (setting "1") can be selected using Pr.850 under real sensorless vector control.
- This function selects either zero speed control or servo lock for braking operation when pre-excitation is performed with the LX signal during speed control operation under vector control. Turning on the LX signal enables the pre-excitation function.

Pr.802 Setting	Braking Operation	Description
0 (initial value)	Zero speed control	Even under load, an attempt is made to maintain 0r/min to keep the motor shaft stopped. Note that if the shaft is overcome and turned by external force, it does not return to the original position.
1	Servo lock	Even under load, an attempt is made to maintain the motor shaft position. Note that if the shaft is turned by external force, it returns to the original position after the external force has gone away.

- Set the frequency at which control changes to zero speed control or servo lock control (select using Pr.802) in Pr.10 and operation time in Pr.11 during vector control. The initial value of Pr.10 automatically changes to 0.5Hz during vector control.

Pr 13, 571
Starting frequency

Pr.13 Starting frequency	Pr.571 Holding time at a start
--------------------------	--------------------------------

You can set the starting frequency and hold the set starting frequency for a certain period of time.

Set these functions when you need the starting torque or want smooth motor drive at a start.

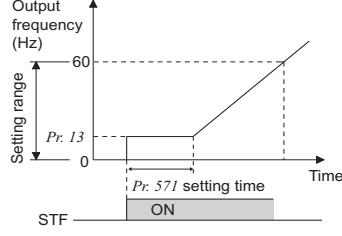

Pr 14 V/F pattern matching applications

Pr.14 Load pattern selection

You can select the optimum output characteristic (V/F characteristic) for the application and load characteristics. This function is valid for V/F control only.

Setting "0" (initial value)
setting "4, 5", RT signal is on
For rated torque load

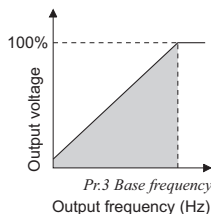

Setting "1"
For variable-torque load

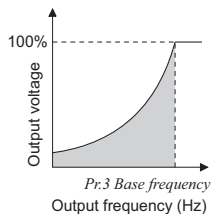

Setting "2"
setting "4", RT signal is off
For elevator loads

At forward rotation boost...Pr.0 setting
 At reverse rotation boost...0%

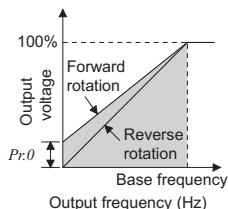

Setting "3"
setting "5", RT signal is off
For elevator loads

At forward rotation boost...0%
 At reverse rotation boost...Pr.0 setting

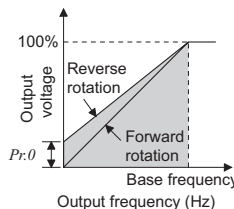

Pr 15, 16 Jog operation

Pr.15 Jog frequency Pr.16 Jog acceleration/deceleration time

You can set the frequency and acceleration/deceleration time for jog operation. Jog operation can be performed from either the outside or PU.

Can be used for conveyor positioning, test operation, etc.

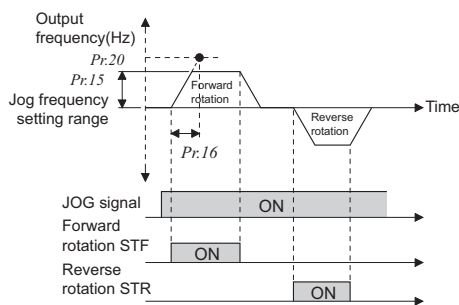

Pr 17 Logic selection of output stop signal (MRS)

Pr.17 MRS input selection

The inverter output can be shut off by the MRS signal. Also, logic for the MRS signal can be selected.

When Pr. 17 is set to "4", the MRS signal from external terminal (output stop) can be changed to the normally closed (NC contact) input, and the MRS signal from communication can be changed to the normally open (NO contact) input.

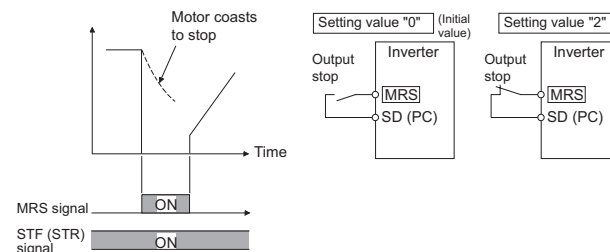

Pr. 18 ➤ Refer to the section about Pr. 1.

Pr. 19 ➤ Refer to the section about Pr. 3.

Pr. 20, 21 ➤ Refer to the section about Pr. 7.

Pr 22, 23, 48, 49, 66, 114, 115, 148, 149, 154, 156, 157, 858, 868 Stall prevention operation

Pr.22 Stall prevention operation level	Pr.49 Second stall prevention operation frequency
Pr.23 Stall prevention operation level compensation factor at double speed	Pr.66 Stall prevention operation reduction starting frequency
Pr.48 Second stall prevention operation current	Pr.114 Third stall prevention operation current
Pr.66 Stall prevention operation reduction starting frequency	Pr.115 Third stall prevention operation frequency
Pr.114 Third stall prevention operation current	Pr.148 Stall prevention level at 0V input
Pr.148 Stall prevention level at 0V input	Pr.149 Stall prevention level at 10V input
Pr.154 Voltage reduction selection during stall prevention operation	Pr.156 Stall prevention operation selection
Pr.156 Stall prevention operation selection	Pr.157 OL signal output timer
Pr.858 Terminal 4 function assignment	Pr.868 Terminal 1 function assignment

This function monitors the output current and automatically changes the output frequency to prevent the inverter from coming to an alarm stop due to overcurrent, overvoltage, etc. It can also limit stall prevention and fast-response current limit operation during acceleration/deceleration, driving or regeneration. Invalid for vector control.

- **Stall prevention**
 If the output current exceeds the stall prevention operation level, the output frequency of the inverter is automatically varied to reduce the output current. Also the second and third stall prevention function can restrict the output frequency range in which the stall prevention function is valid.
- **Fast-response current limit**
 If the current exceeds the limit value, the output of the inverter is shut off to prevent an overcurrent.
- **Set in Pr.22 the percentage of the output current to the rated inverter current at which stall prevention operation will be performed.**
 Normally set this parameter to 150% (initial value).
 For the 3.7kW or less, the Pr.22 setting changes from 150% (initial value) to 200% when operation is changed from V/F control or advanced magnetic flux vector control to real sensorless vector control or vector control.
- **To set stall prevention operation level using an analog signal from terminal 1 (terminal 4) , set "4" in Pr.868 (Pr. 858).** For the adjustment of bias/gain of analog signal, use Pr.148 and Pr.149.

- During high-speed operation above the rated motor frequency, acceleration may not be made because the motor current does not increase. If operation is performed in a high frequency range, the current at motor lockup becomes smaller than the rated output current of the inverter, and the protective function (OL) is executed even if the motor is at a stop.

To improve the operating characteristics of the motor in this case, the stall prevention level can be reduced in the high frequency range. This function is effective for performing operation up to the high-speed range on a centrifugal separator etc. Normally, set 60Hz in Pr.66 and 100% in Pr.23.

- By setting "9999" (initial value) in Pr.23 Stall prevention operation level compensation factor at double speed, the stall prevention operation level is constant at the Pr.22 setting up to 400Hz.

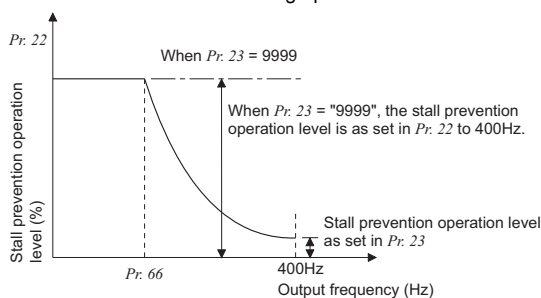

- Setting "9999" in Pr.49 Second stall prevention operation frequency and turning the RT signal on make Pr.48 Second stall prevention operation current valid.
- Setting a value other than "0" in Pr.115 Third stall prevention operation frequency and turning the X9 signal on make Pr.114 Third stall prevention operation current valid.
- The stall prevention operation level from 0Hz to the output frequency set in Pr.49 (Pr.115) can be set in Pr. 48 (Pr.114).

Set frequency > exceeds Pr. 49(Pr.115)

Set frequency is Pr. 49 (Pr.115) or less

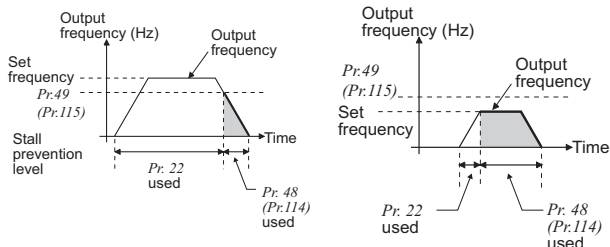

Pr.49 Setting	Pr.115 Setting	Operation
0 (initial value)		The second (third) stall prevention function is not activated.
0.01Hz to 400Hz		The second (third) stall prevention function is activated according to the frequency.
9999	—	The second stall prevention function is performed according to the RT signal. RT signal on...Stall level Pr.48 RT signal off...Stall level Pr.22

- Stall prevention operation and fast response current limit function can be limited according to the operation condition using Pr.156.
- When real sensorless vector control is selected using Pr.800, Pr.22 serves as a torque limit level.

Pr. 22, 803, 810 to 817, 858, 868, 874

Torque limit level Sensorless Vector

Pr.22 Torque limit level	
Pr.803 Constant power range torque characteristic selection	
Pr.810 Torque limit input method selection	Pr.811 Set resolution switchover
Pr.812 Torque limit level (regeneration)	Pr.813 Torque limit level (3rd quadrant)
Pr.814 Torque limit level (4th quadrant)	Pr.815 Torque limit level 2
Pr.816 Torque limit level during acceleration	Pr.817 Torque limit level during deceleration
Pr.858 Terminal 4 function assignment	Pr.868 Terminal 1 function assignment
Pr.874 OLT level setting	

This function limits the output torque to the predetermined value during speed control under real sensorless vector control or vector control.

- Set the torque limit level within the range 0 to 400% in Pr.22 .
If the TL signal is turned on, torque limit level 2 (Pr.815) functions.
- You can select whether the torque limit level is set using parameters or analog input terminals (terminal 1, 4).
In addition, you can set torque limit level for forward (power driving/regeneration) and reverse (power driving/regeneration) operation individually.

Pr. Number	Setting Range	Description
810	0 (initial value)	Torque limit by parameter
	1	Torque limit based on the analog input from terminal 1 and 4.
812	0 to 400%	Set the torque limit level for forward rotation regeneration.
	9999 (initial value)	Pr.22 value is used for limit.
813	0 to 400%	Set the torque limit level for reverse rotation driving.
	9999 (initial value)	Pr.22 value is used for limit.
814	0 to 400%	Set the torque limit level for reverse rotation regeneration.
	9999 (initial value)	Pr.22 value is used for limit.

- To set torque limit level using an analog signal from terminal 1 (terminal 4) , set "1" in Pr.810 and "4" in Pr.868 (Pr.858).
- Torque limit value during acceleration/deceleration can be set using Pr.816 and Pr.817.
- You can select whether the torque limit in the constant output range be constant torque limit or constant output limit using Pr.803.
- This function can make an alarm stop if the torque limit is activated to stall the motor. Set the output torque at which an alarm stop is made in Pr.874 .
- Using Pr.811, the setting increments of the parameter-set torque limit can be changed from 0.1% to 0.01% increments. (valid during vector control)
- When V/F control and advanced magnetic flux vector control are selected using Pr.800, Pr.22 serves as a stall prevention operation level.

Pr. 24 to 27 ➔ Refer to the section about Pr. 4.

Pr. 28

Input compensation of multi-speed and remote setting

Pr.28 Multi-speed input compensation selection

By inputting the frequency setting compensation signal (terminal 1, 2), speed (frequency) compensation can be applied for the speed setting such as the multi-speed setting and remote setting function.

Pr.28 Setting	Description
0 (initial value)	Without compensation
1	With compensation

Pr. 29, 140 to 143, 380 to 383, 516 to 519

Acceleration/deceleration pattern and backlash measures

- Pr.29 Acceleration/deceleration pattern selection
- Pr.141 Backlash acceleration stopping time
- Pr.143 Backlash deceleration stopping time
- Pr.381 Deceleration S-pattern 1
- Pr.383 Deceleration S-pattern 2
- Pr.517 S-pattern time at a completion of acceleration
- Pr.519 S-pattern time at a completion of deceleration
- Pr.140 Backlash acceleration stopping frequency
- Pr.142 Backlash deceleration stopping frequency
- Pr.380 Acceleration S-pattern 1
- Pr.382 Acceleration S-pattern 2
- Pr.516 S-pattern time at a start of acceleration
- Pr.518 S-pattern time at a start of deceleration

Acceleration/deceleration patterns suitable for applications can be selected.

The backlash measures to stop acceleration/deceleration at the frequency and time set in parameter during acceleration/deceleration can be set.

- Linear acceleration/deceleration (setting "0", initial value)
 - For the inverter operation, the output frequency is made to change linearly (linear acceleration/deceleration) to prevent the motor and inverter from excessive stress to reach the set frequency during acceleration, deceleration, etc. when frequency changes.

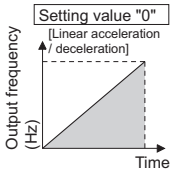

- S-pattern acceleration/deceleration A (setting "1")
 - For machine tool spindle applications, etc. Used when acceleration/deceleration must be made in a short time to a high-speed range of not lower than the base frequency.

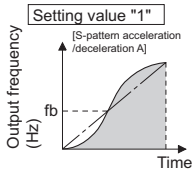

- S-pattern acceleration/deceleration B (setting "2")
 - For prevention of load shifting in conveyor and other applications. Since acceleration/deceleration is always made in an S shape from current frequency (f2) to target frequency (f1), this function eases shock produced at acceleration/deceleration and is effective for load collapse prevention, etc.

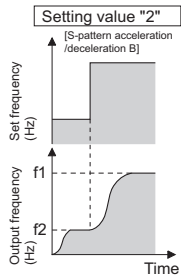

- Backlash measures (setting "3", Pr.140 to Pr.143)

- To avoid backlash, acceleration/deceleration is temporarily stopped. Set the acceleration/deceleration stopping frequency and time in Pr.140 to Pr.143.

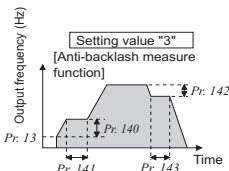

- S-pattern acceleration/deceleration C (setting "4", Pr.380 to Pr.383)
 - The S-pattern acceleration/deceleration C switch signal (X20) changes an acceleration/deceleration curve.
 - Set % of time taken for forming an S-pattern in Pr.380 to Pr.383 as acceleration time is 100%.

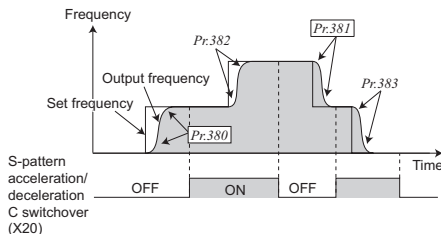

- S-pattern acceleration/deceleration D (setting "5", Pr.516 to Pr.519)
 - Set the time taken for operations for S-pattern of S-pattern acceleration/deceleration in Pr.516 to Pr.519.

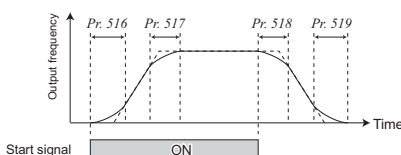

Pr. 30, 70

Selection of regeneration unit

- Pr.30 Regenerative function selection
- Pr.70 Special regenerative brake duty

- When making frequent starts/stops, use the optional "high-duty brake resistor (FR-ABR)" to increase the regenerative brake duty. (22K or less)
- Use the power regeneration common converter (FR-CV for the 55K or less) or power regeneration converter (MT-RC 75K or more) for continuous operation in regeneration status. Use a high efficiency converter (FR-HC for the 55K or less, MT-HC for the 75K or more) for harmonic suppression and power factor improvement.
- For the 75K or more, use the brake unit MT-BU5 or BR5 when the regenerative brake duty is need to be increased due to frequent starts and stops.
- You can select either DC feeding mode 1 in which operation is performed with DC power (terminal P, N) or DC feeding mode 2 in which operation is performed normally with the AC power (R, S, T) and performed with DC power such as battery at occurrence of power failure.

<55K or less>

Pr.30 Setting	Pr.70 Setting	Regeneration Unit	Power Supply
0 (initial value)	*1	Built-in brake, brake unit (FR-BU, BU)	R, S, T
1	10/6% *2	High-duty brake resistor (FR-ABR)	R, S, T
2	0% (initial value)	High power factor converter (FR-HC), power regeneration common converter (FR-CV)	P, N
10	*1	Built-in brake, brake unit (FR-BU, BU)	P, N
11	10/6% *2	High-duty brake resistor (FR-ABR)	P, N
20	*1	Built-in brake, brake unit (FR-BU, BU)	R, S, T/P, N
21	10/6% *2	High-duty brake resistor (FR-ABR)	R, S, T/P, N

*1 The brake duty varies according to the inverter capacity.

*2 7.5K or less/11K or more

<75K or more>

Pr.30 Setting	Pr.70 Setting	Regeneration Unit	Power Supply
0 (initial value)	—	Not used	R, S, T
1	0%	Power regeneration converter (MT-RC)	R, S, T
	10%	Brake unit (MT-BU5)	
2	—	High power factor converter (MT-HC)	P, N
10	—	Not used	P, N
11	10%	Brake unit (MT-BU5)	P, N
20	—	Not used	R, S, T/P, N
21	10%	Brake unit (MT-BU5)	R, S, T/P, N

Pr. 31 to 36

Avoid mechanical resonance points (frequency jump)

- Pr.31 Frequency jump 1A
- Pr.32 Frequency jump 1B
- Pr.33 Frequency jump 2A
- Pr.34 Frequency jump 2B
- Pr.35 Frequency jump 3A
- Pr.36 Frequency jump 3B

When it is desired to avoid resonance attributable to the natural frequency of a mechanical system, these parameters allow resonant frequencies to be jumped.

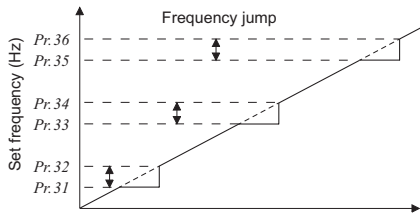

- Up to three areas may be set, with the jump frequencies set to either the top or bottom point of each area.
- The value set to 1A, 2A or 3A is a jump point and operation in the jump zone is performed at these frequencies.
- Frequency jump is not performed if the initial value is set to "9999".
- During acceleration/deceleration, the running frequency within the set area is valid.

Pr. 37, 144, 505, 811

Speed display and speed setting

- Pr.37 Speed display
- Pr.144 Speed setting switchover
- Pr. 505 Speed setting reference
- Pr. 811 Set resolution switchover

The monitor display and frequency setting of the PU (FR-DU07/FR-PU04/FR-PU07) can be changed to the motor speed and machine speed.

- When the running speed monitor is selected, each monitor and setting are determined according to the combination of Pr.37 and Pr.144. (The units within the thick frame are the initial values.)
- Using Pr.811, the setting increments of running speed monitor and speed setting (r/min) can be changed from 1r/min to 0.1 r/min.

Pr.37 Setting	Pr.144 Setting	Output Frequency Monitor	Set Frequency Monitor	Running Speed Monitor	Frequency Setting Parameter Setting
0	0	Hz	Hz	r/min*1	Hz
	2 to 10	Hz	Hz	r/min*1	Hz
	102 to 110	r/min*1	r/min*1	r/min*1	r/min*1
1 to 9998	0	Hz	Hz	Machine speed*1	Hz
	2 to 10	Machine speed*1	Machine speed*1	Machine speed*1	Machine speed*1
	102 to 110	Hz	Hz	r/min*1	Hz

*1 Motor speed (r/min) conversion formula ... frequency × 120/number of motor poles (Pr.144)
 Machine speed conversion formula Pr.37 × frequency/Pr. 505
 For Pr.144 in the above formula, the value is "Pr.144 - 100" when "102 to 110" is set in Pr.144 and the value is "4" when Pr.37 = 0 and Pr.144 = 0.
 *2 The increments for Hz are 0.01Hz, machine speed are 1m/min, and r/min are 1r/min.
 *3 Running speed monitor displays actual motor speed (encoder) during encoder feedback control and vector control.

Pr. 41 to 43, 50, 116, 865

Detection of output frequency and motor speed (SU, FU, FU2, FU3, FB, FB2, FB3, LS signal)

- Pr.41 Up-to-frequency sensitivity
- Pr.42 Output frequency detection
- Pr.43 Output frequency detection for reverse rotation
- Pr.50 Second output frequency detection
- Pr.116 Third output frequency detection
- Pr.865 Low speed detection

The inverter output frequency is detected and output at the output signals.

- The Pr.41 value can be adjusted within the range ±1% and ±100% on the assumption that the set frequency is 100%.
- This parameter can be used to ensure that the running frequency has been reached to provide the operation start signal etc. for related equipment.

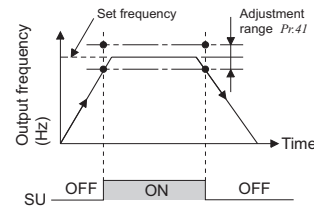

- When the output frequency reaches or exceeds the Pr.42 setting, the output frequency detection signals (FU, FB) are output. This function can be used for electromagnetic brake operation, open signal, etc.
- When the detection frequency is set in Pr.43, frequency detection for reverse rotation use only can also be set. This function is effective for switching the timing of electromagnetic brake operation between forward rotation (rise) and reverse rotation (fall) during vertical lift operation, etc.
- When outputting a frequency detection signal besides the FU (FB) signal, set the detection frequency in Pr.50 or Pr.116. The FU2 (FB2) signal is output when the output frequency reaches or exceeds the Pr.50 setting (FU3 (FB3) signal is output if reaches or exceeds the Pr.116 setting).

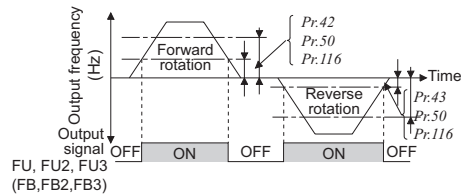

- The FU (FU2 and FU3) signal is output when the output frequency reaches the speed command value and output the FB (FB2, FB3) signal when the output frequency reaches the actual motor speed (estimated actual speed value) under real sensorless vector control and vector control. (The output timing of the FU and FB signals is the same under V/F control and advanced magnetic flux vector control.)
- The LS signal is output when the output frequency reduces below the Pr.865 setting under real sensorless vector control and vector control. The signal is output during inverter operation under the following conditions.

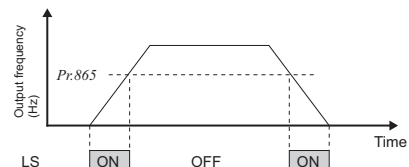

Pr. 44, 45 ➤ Refer to the section about Pr. 7.

Pr. 46 ➤ Refer to the section about Pr. 0.

Pr. 47 ➤ Refer to the section about Pr. 3.

Pr. 48, 49 ➤ Refer to the section about Pr. 22.

Pr. 50 ➤ Refer to the section about Pr. 41.

Pr. 51 ➤ Refer to the section about Pr. 9.

Pr. 52, 54, 158, 170, 171, 268, 563, 564, 867, 891

Change of DU/PU monitor descriptions, cumulative monitor clear

Pr.52 DU/PU main display data selection	Pr.54 FM terminal function selection
Pr.158 AM terminal function selection	Pr.170 Watt-hour meter clear
Pr.171 Operation hour meter clear	Pr.268 Monitor decimal digits selection
Pr.563 Energization time carrying-over times	Pr.564 Operating time carrying-over times
Pr.867AM output filter	Pr.891 Cumulative power monitor digit shifted times

The monitor to be displayed on the main screen of the operation panel (FR-DU07)/parameter unit (FR-PU04/FR-PU07) can be selected.

Types of Monitor	Unit	Pr.52 Parameter Setting Value		Pr.54 (FM) Pr.158 (AM) Setting	Full-Scale Value
		DU LED	PU main monitor		
Output frequency	0.01Hz	0/100		1	Pr.55
Output current	0.01A/0.1A*7	0/100		2	Pr.56
Output voltage	0.1V	0/100		3	200V class: 400V 400V class: 800V
Alarm display	—	0/100		—	—
Frequency setting	0.01Hz	5	*1	5	Pr.55
Running speed	1(r/min)	6	*1	6	The value converted with the Pr.37 value from Pr.55.
Motor torque *2	0.1%	7	*1	7	Pr.866
Converter output voltage	0.1V	8	*1	8	200V class: 400V 400V class: 800V
Regenerative brake duty	0.1%	9	*1	9	Brake duty set in Pr.30 and Pr.70
Electronic thermal relay function load factor	0.1%	10	*1	10	Electronic thermal relay function operation level
Output current peak value	0.01A/0.1A*7	11	*1	11	Pr.56
Converter output voltage peak value	0.1V	12	*1	12	200V class: 400V 400V class: 800V
Input power	0.01kW/0.1kW*7	13	*1	13	Rated inverter power x 2
Output power	0.01kW/0.1kW*7	14	*1	14	Rated inverter power x 2
Input terminal status	—	55	*1	—	—
Output terminal status	—		*1	—	—
Option input terminal status	—	56	x	—	—
Option output terminal status	—	57	x	—	—
Load meter	0.1%	17		17	Pr.866
Motor excitation current	0.01A/0.1A*7	18		18	Pr.56
Position pulse*3	—	19		—	—
Cumulative energization time*4	1h	20		—	—
Reference voltage output	—	—		21	—
Orientation status *3	1	22		—	—
Actual operation time*4, 5	1h	23		—	—
Motor load factor	0.1%	24		24	200%
Cumulative power	0.01kWh/0.1kWh*6*7	25		—	—
Torque command	0.1%	32		32	Pr.866
Torque current command	0.1%	33		33	Pr.866
Motor output	0.01kW/0.1kW*7	34		34	Rated motor capacity
Feedback pulse	—	35		—	—
Power saving effect	Variable according to parameters	50		50	Inverter capacity
Cumulative saving power	—	51		—	—
PID set point	0.1%	52		52	100%
PID measured value	0.1%	53		53	100%
PID deviation	0.1%	54		—	—

- *1 Selected by the parameter unit (FR-PU04/FR-PU07)
- *2 The motor torque display remains "0" under V/F control.
- *3 Position pulse and orientation status function when used with an option (FR-A7AP) and orientation control is made valid. When orientation control is invalid, "0" remains displayed and these functions are invalid.
- *4 The cumulative energization time and actual operation time are accumulated from 0 to 65535 hours, then cleared, and accumulated again from 0.
When the operation panel (FR-DU07) is used, the time is displayed up to 65.53 (65530h) on the assumption that 1h=0.001, and thereafter, it is added up from 0.
- *5 The actual operation time is not added up if the cumulative operation time before power supply-off is less than 1h.
- *6 When using the parameter unit (FR-PU04/FR-PU07), "kW" is displayed.
- *7 The setting depends on the inverter capacity. (55K or less/75K or more)
- *8 Available only when the FR-A7AP is mounted.

- The digits of the cumulative power monitor value can be shifted to the right for the number of Pr.891 settings.
- Writing "0" in Pr.170 clears the cumulative power monitor.
- You can check the numbers of cumulative energization time monitor exceeded 65535h with Pr.563 and the numbers of actual operation time monitor exceeded 65535h with Pr.564.
- Writing "0" in Pr.171 clears the actual operation time monitor.

Pr.268 Setting	Description
9999 (initial value)	No function
0	When 1 or 2 decimal places (0.1 increments or 0.01 increments) are monitored, the decimal places are dropped and the monitor displays an integer value (1 increments). The monitor value of 0.99 or less is displayed as 0.
1	When 2 decimal places (0.01 increments) are monitored, the 0.01 decimal place is dropped and the monitor displays the first decimal place (0.1 increments). When the monitor display digit is originally in 1 increments, it is displayed unchanged in 1 increments.

- When Pr.52 is set to "100", the set frequency monitor is displayed during a stop and the output frequency monitor is displayed during operation. (LED of Hz flickers during stop and is lit during operation.)

	Pr.52		
	0	100	
	During running/stop	During stop	During running
Output frequency	Output frequency	Set frequency	Output frequency
Output current	Output current		
Output voltage	Output voltage		
Alarm display	Alarm display		

- Using Pr.867, the output voltage response of the terminal AM can be adjusted within the range 0 to 5s.

Pr. 55, 56, 866

Reference of the monitor output from terminal FM and AM

Pr.55 Frequency monitoring reference	Pr.56 Current monitoring reference
Pr.866 Torque monitoring reference	

Set the full-scale value of the monitor value output from terminal FM and AM.

Monitor*	Reference Parameter	Initial Value
Frequency	Pr.55	60Hz
Current	Pr.56	Rated inverter current
Torque	Pr.866	150%

- * Refer to the section about Pr.52 for monitor names.

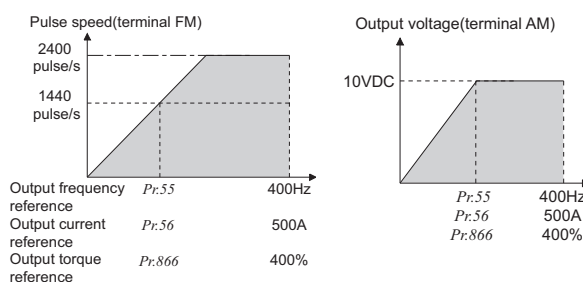

Pr. 57, 58, 162 to 165, 299, 611
Automatic restart operation after instantaneous power failure/flying start

- Pr.57 Restart coasting time
- Pr.58 Restart cushion time
- Pr.162 Automatic restart after instantaneous power failure selection
- Pr.163 First cushion time for restart
- Pr.164 First cushion voltage for restart
- Pr.165 Stall prevention operation level for restart
- Pr.299 Rotation direction detection selection at restarting
- Pr.611 Acceleration time at a restart

You can restart the inverter without stopping the motor in the following cases:

- when commercial power supply operation is switched to inverter operation
- when power comes back on after an instantaneous power failure
- when motor is coasting at start

Pr. Number	Setting Range	Description
57	0	1.5K or less.....0.5s, 2.2K to 7.5K.....1s, 11K to 55K.....3s 75K or more.....5s The above times are coasting time.
	0.1 to 5s/ 0.1 to 30s *	Set the waiting time for inverter-triggered restart after an instantaneous power failure.
	9999 (initial value)	No restart
58	0 to 60s	Set a voltage starting time at restart.
162	0 (initial value)	With frequency search
	1	Without frequency search (reduced voltage system)
	2	Encoder detection frequency
	10	Frequency search at every start
	11	Reduced voltage system at every start
12	Encoder detection frequency at every start	
163	0 to 20s	Set a voltage starting time at restart. Consider using these parameters according to the load (moment of inertia/ torque) magnitude.
164	0 to 100%	
165	0 to 220%	Consider the rated inverter current as 100% and set the stall prevention operation level during restart operation.
299	0	Without rotation direction detection
	1	With rotation direction detection
	9999	When Pr.78=0, the rotation direction is detected. When Pr.78=1,2, the rotation direction is not detected.
611	0 to 3600s	Set the acceleration time to reach the set frequency at a restart.
	9999	Acceleration time for restart is the normal acceleration time (e.g. Pr.7).

* The setting range depends on the inverter capacity. (55K or less/75K or more)

<Connection diagram>

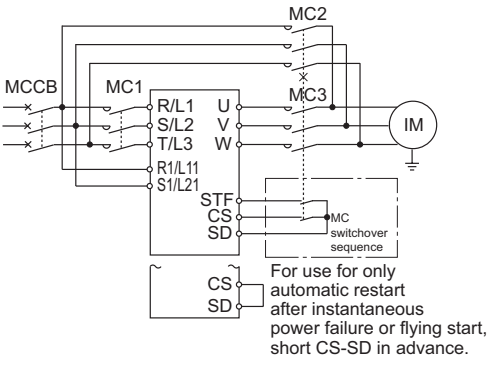

- When "0 (initial value) or 10" is set in Pr.162, the inverter smoothly starts after detecting the motor speed upon power restoration.
- The motor starts at the motor speed and in the rotation direction detected from the encoder at power restoration when "2 or 12" is set in Pr.162 under encoder feedback control or vector control. (Valid when the FR-A7AP is fitted)
- Even when the motor is rotating in the opposite direction, the inverter can be restarted smoothly as the direction of rotation is detected. (You can select whether to make rotation direction detection or not with Pr.299 Rotation direction detection selection at restarting.)

V/F control, advanced magnetic flux vector control

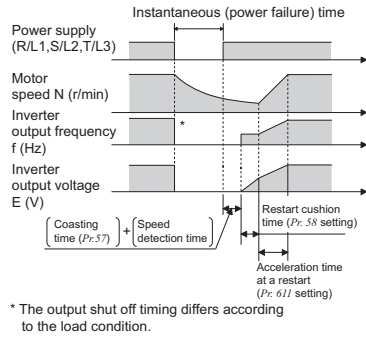

* The output shut off timing differs according to the load condition.

Real sensorless vector control, vector control

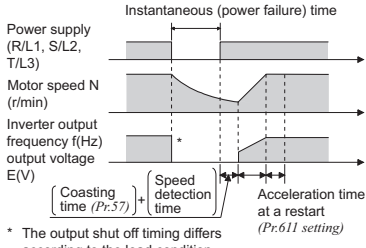

* The output shut off timing differs according to the load condition.

- When Pr.162="1" or "11", automatic restart operation is performed in a reduced voltage system, where the voltage is gradually risen with the output frequency unchanged from prior to an instantaneous power failure independently of the coasting speed of the motor. For real sensorless vector control, output frequency and voltage before instantaneous power failure are output. (Pr. 58 is made invalid)

V/F control, advanced magnetic flux vector control

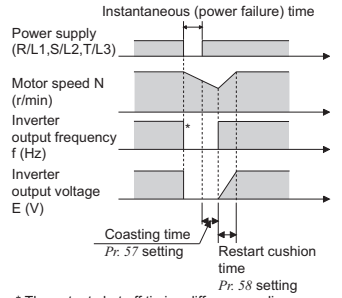

* The output shut off timing differs according to the load condition.

Real sensorless vector control

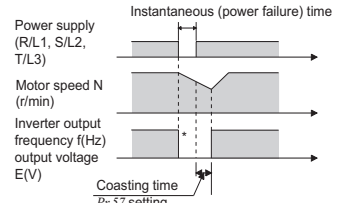

* The output shut off timing differs according to the load condition.

Pr. 59 Remote setting function

Pr.59 Remote function selection

- Even if the operation panel is located away from the enclosure, you can use contact signals to perform continuous variable-speed operation, without using analog signals.
- By merely setting this parameter, you can use the acceleration, deceleration and setting clear functions of the motorized speed setter (FR-FK).

Pr.59 Setting	Description	
	RH, RM, RL signal function	Frequency setting storage function
0 (initial value)	Multi-speed setting	—
1	Remote setting	With
2	Remote setting	Not used
3	Remote setting	Not used (Turning off STF/STR clears remotely set frequency used)

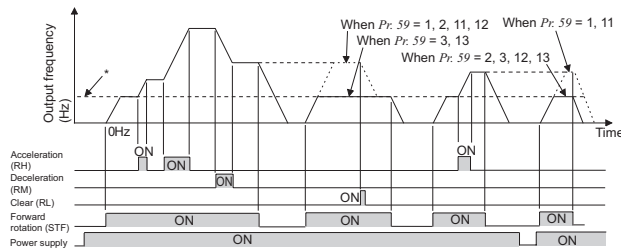

* External running frequency (other than multi-speed) or PU running frequency

Pr. 60 Energy saving control selection

V/F

Pr.60 Energy saving control selection

Without a fine parameter setting, the inverter automatically performs energy saving operation. This inverter is optimum for fan and pump applications. Valid only under V/F control.

Pr. 60 Setting	Description
0 (initial value)	Normal operation mode
4	Energy saving operation mode In the energy saving operation mode, the inverter automatically controls the output voltage to minimize the inverter output voltage during a constant operation.*

* Since output voltage is controlled in energy saving operation mode, output current may slightly increase.

Pr. 61 to 64, 292, 293 Automatic acceleration/deceleration

Pr.61 Reference current

Pr.62 Reference value at acceleration

Pr.63 Reference value at deceleration

Pr.64 Starting frequency for elevator mode

Pr.292 Automatic acceleration/deceleration

Pr.293 Acceleration/deceleration separate selection

The inverter automatically sets appropriate parameters for operation.

- The inverter operates in the same conditions as when appropriate values are set in each parameter even if acceleration/deceleration time and V/F pattern are not set. This operation mode is useful when you just want to operate, etc. without fine parameter setting.
- Even if automatic acceleration/deceleration has been selected, inputting the jog, RT (second function selection) or X9 (third function selection) signal during an inverter stop will switch to the normal operation and give priority to jog operation, second function selection or third function selection. After automatic acceleration/deceleration operation has been started, none of jog signal, RT signal and RT signal are accepted.

Pr.292 Setting	Operation	Automatic Setting Parameter
0 (initial value normal mode)	—	—
1 (shortest acceleration/ deceleration mode)	Without brake resistor and brake unit	Set when you want to accelerate/decelerate the motor for the shortest time. (stall prevention operation level 150%) <i>Pr.7, Pr.8</i>
11 (shortest acceleration/ deceleration mode)	With brake resistor and brake unit	
3 (optimum acceleration/ deceleration mode)	The inverter performs optimum operation fully utilizes its' capability within the continuous	<i>Pr.0, Pr.7, Pr.8</i>
5 (elevator mode 1)	Stall prevention operation level 150%	Inverter output voltage is controlled so that enough torque can be generated even under power driving and regeneration. <i>Pr.0, Pr.13, Pr.19</i>
6 (elevator mode 2)	Stall prevention operation level 180%	
7 (brake sequence mode 1)	With mechanical brake opening completion signal input	Operation mode in which a machine brake operation timing signal for vertical lift applications is output.
8 (brake sequence mode 2)	Without mechanical brake opening completion signal input	

- Use *Pr.61 to Pr.63* to change the reference current for the shortest acceleration/deceleration mode and optimum acceleration/ deceleration mode.
- Use *Pr.64* to set the starting frequency for the elevator mode.
- Calculation of acceleration/deceleration can be performed individually.

This function is made valid in the shortest acceleration/deceleration mode and optimum acceleration/deceleration mode.

Pr.293 Setting	Description
0 (initial value)	Both acceleration/deceleration time is calculated.
1	Only acceleration time is calculated.
2	Only deceleration time is calculated.

Pr. 65, 67 to 69
Retry function at alarm occurrence

Pr.65 Retry selection Pr.67 Number of retries at fault occurrence
 Pr.68 Retry waiting time Pr.69 Retry count display erase

If an alarm occurs, the inverter resets itself automatically to restart. You can also select the alarm description for a retry. When automatic restart after instantaneous power failure is selected (Pr.57 Restart coasting time ≠9999), restart operation is performed at retry operation as at an instantaneous power failure.

- Use Pr.65 to select the alarm to be activated for retries. "●" indicates the alarms selected for retry.

Alarm Indication for Retry	Pr.65 Setting					
	0	1	2	3	4	5
E.OC1	●	●		●	●	●
E.OC2	●	●		●	●	
E.OC3	●	●		●	●	●
E.OV1	●		●	●	●	
E.OV2	●		●	●	●	
E.OV3	●		●	●	●	
E.THM	●					
E.THT	●					
E.IPF	●				●	
E.UVT	●				●	
E. BE	●				●	
E. GF	●				●	
E.OHT	●					
E.OLT	●				●	
E.OPT	●				●	
E.OP1	●				●	
E.OP2	●				●	
E.OP3	●				●	
E. PE	●				●	
E.MB1	●				●	
E.MB2	●				●	
E.MB3	●				●	
E.MB4	●				●	
E.MB5	●				●	
E.MB6	●				●	
E.MB7	●				●	
E.OS	●				●	
E.OSD	●				●	
E.OD	●				●	
E.PTC	●					
E.CDO	●				●	
E.SER	●				●	
E.ILF	●				●	

- Set the number of retries at alarm occurrence in Pr.67.

Pr.67 Setting	Description
0 (initial value)	No retry function
1 to 10	Set the number of retries at alarm occurrence. An alarm output is not provided during retry operation.
101 to 110	Set the number of retries at alarm occurrence. (The setting value of minus 100 is the number of retries.) An alarm output is provided during retry operation.

- Use Pr.68 to set the waiting time from when an inverter alarm occurs until a retry is made in the range 0 to 10s.
- Reading the Pr.69 value provides the cumulative number of successful restart times made by retry.

Pr. 66 ➤ Refer to the section about Pr. 22.

Pr. 67 to 69 ➤ Refer to the section about Pr. 65.

Pr. 70 ➤ Refer to the section about Pr. 30.

Pr. 71, 450
Motor selection (applied motor)

Pr.71 Applied motor Pr.450 Second applied motor

Setting of the used motor selects the thermal characteristic appropriate for the motor.

Setting is necessary when using a constant-torque motor. Thermal characteristic of the electronic thermal relay function suitable for the motor is set.

Pr. 71, Pr.450 Setting	Thermal Characteristic of the Electronic Thermal Relay Function	Motor (○: Motor used)		
		Standard (SF-JR, etc.)	Constant torque (SF-JRCA, etc.)	Vector (SF-V5RU, etc.)
0	Thermal characteristics of a standard motor (Pr. 71 initial value)	○		
1	Thermal characteristics of the Mitsubishi constant-torque motor		○	
2	Thermal characteristics of a standard motor Adjustable 5 points V/F	○		
20	Mitsubishi standard motor SF-JR4P (1.5kW or less) thermal characteristic for the constant-torque motor	○		
30	Thermal characteristics of the Mitsubishi vector motor SF-V5RU			○
40	Thermal characteristic of Mitsubishi standard motor SF-HR	○*1		
50	Thermal characteristic of Mitsubishi constant-torque motor SF-HRCA		○*2	
3	Standard	○		
13	Constant-torque		○	
23	Mitsubishi standard SF-JR4P (1.5kW or less)	○		
33	Mitsubishi vector SF-V5RU/SF-THY			○
43	Mitsubishi high efficiency SF-HR	○*1		
53	Mitsubishi constant-torque SF-HRCA		○*2	
4	Standard	○		
14	Constant-torque		○	
24	Mitsubishi standard SF-JR4P (1.5kW or less)	○		
34	Mitsubishi vector SF-V5RU/SF-THY			○
44	Mitsubishi high efficiency SF-HR	○*1		
54	Mitsubishi constant-torque SF-HRCA		○*2	
5	Standard *3	○		
15	Constant-torque *3		○	
6	Standard *4	○		
16	Constant-torque *4		○	
7	Standard *3	○		
17	Constant-torque *3		○	
8	Standard *4	○		
18	Constant-torque *4		○	
9999	Function invalid (only Pr.450 can be set, initial value)			

- *1 Motor constants of Mitsubishi high efficiency motor SF-HR
- *2 Motor constants of Mitsubishi constant-torque motor SF-HRCA.
- *3 Star connection
- *4 Delta connection

- For the 5.5K and 7.5K, the Pr. 0 Torque boost and Pr. 12 DC injection brake operation voltage settings are automatically changed according to the Pr. 71 and Pr.450 settings as follows.

Pr.71 Pr.450	Standard Motor Setting 0, 2, 3 to 8, 20, 23, 24, 40, 43, 44	Constant-Torque Motor Setting 1, 13 to 18, 50, 53, 54
Pr.0	3%	2%
Pr.12	4%	2%

Pr. 72, 240
Carrier frequency and SoftPWM selection

Pr.72 PWM frequency selection Pr.240 Soft-PWM operation selection

You can change the motor sound.

Pr.Number	Setting Range	Description
72	0 to 15/ 0 to 6, 25*	PWM carrier frequency can be changed. Note that 0 indicates 0.7kHz, 15 indicates 14.5kHz and 25 indicates 2.5kHz. (Set 25 when using an optional sine wave filter.) The following settings are for real sensorless vector control or vector control. 0 to 5: 2kHz, 6 to 9: 6kHz, 10 to 13: 10kHz, 14 and 15: 14kHz
240	0	Soft-PWM is invalid
	1	When "0 to 5" ("0 to 4" for the 75K or more.) is set in Pr.72, Soft-PWM is valid

* The setting range depends on the inverter capacity. (55K or less/75K or more)

Pr. 73, 242, 243, 252, 253, 267
Analog input selection

Pr.73 Analog input selection
 Pr.242 Terminal 1 added compensation amount (terminal 2)
 Pr.243 Terminal 1 added compensation amount (terminal 4)
 Pr.252 Override bias Pr.253 Override gain
 Pr.267 Terminal 4 input selection

- You can select the function that switches between forward rotation and reverse rotation according to the analog input terminal specifications, override function and input signal polarity.
- For the terminals 1, 2, 4 used for analog input, voltage input (0 to 5V, 0 to 10V) or current input (4 to 20mA) can be selected.
- The additional compensation and fixed ratio of analog compensation (override) using terminal 2 as an auxiliary input can be made to multi-speed operation or the speed setting signal (main speed) of the terminal 2 or terminal 4. (indicates the main speed setting)

Pr.73 Setting	Terminal 2 Input	Terminal 1 Input	Terminal 4 Input	Compensation Input Terminal and Compensation Method	Polarity Reversible		
0	0 to 10V	0 to ±10V	When the AU signal is off ×	Terminal 1 added compensation	Not function (Indicates that a frequency command signal of negative polarity is not accepted.)		
1 (initial value)	0 to 5V	0 to ±10V					
2	0 to 10V	0 to ±5V					
3	0 to 5V	0 to ±5V					
4	0 to 10V	0 to ±10V					
5	0 to 5V	0 to ±5V					
6	4 to 20mA	0 to ±10V					
7	4 to 20mA	0 to ±5V		Terminal 1 added compensation	Function		
10	0 to 10V	0 to ±10V					
11	0 to 5V	0 to ±10V					
12	0 to 10V	0 to ±5V					
13	0 to 5V	0 to ±5V					
14	0 to 10V	0 to ±10V					
15	0 to 5V	0 to ±5V					
16	4 to 20mA	0 to ±10V					
17	4 to 20mA	0 to ±5V					
0	×	0 to ±10V				When the AU signal is on According to the Pr.267 setting 0.4 to 20mA (initial value) 1.0 to 5V 2.0 to 10V	Terminal 1 added compensation
1 (initial value)		0 to ±10V					
2		0 to ±5V					
3		0 to ±5V					
4		0 to 10V	×				
5		0 to 5V	×				
6		×	0 to ±10V				
7		×	0 to ±5V				
10		×	0 to ±10V	Terminal 1 added compensation	Function		
11			0 to ±10V				
12			0 to ±5V				
13			0 to ±5V				
14			0 to 10V				×
15			0 to 5V				×
16			×				0 to ±10V
17		×	0 to ±5V				

When setting parameters, refer to the instruction manual (applied) and understand instructions.

(1) Added compensation (Pr.242, Pr.243)

- The compensation signal can be added to the main speed setting for synchronous/continuous speed control operation, etc.

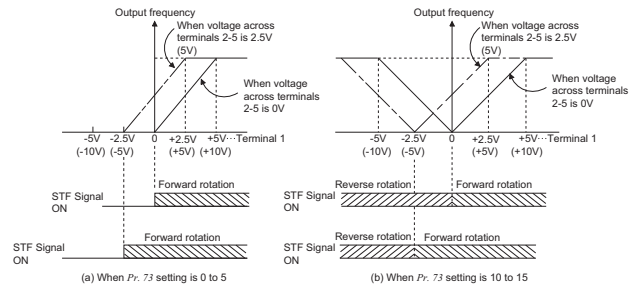

- The terminal 1 (frequency setting auxiliary input) signal is added to the main speed setting signal of terminal 2 or 4.

(2) Override function (Pr. 252, Pr. 253)

- When an override is selected, the terminal 1 or terminal 4 is used for the main speed setting and the terminal 2 for the override signal. (When the main speed of the terminal 1 or terminal 4 is not input, compensation by the terminal 2 is made invalid.)

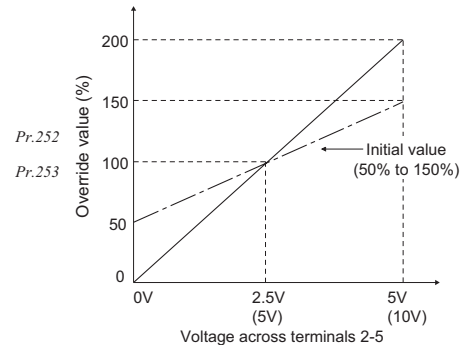

- When "4" is set in Pr.868 (Pr.865), the setting of terminal 1 (terminal 4) is used for stall prevention operation level setting.

Pr. 74, 822, 826, 832, 836, 849
Response level of analog input

Pr.74 Input filter time constant Pr.822 Speed setting filter 1
 Pr.826 Torque setting filter 1 Pr.832 Speed setting filter 2
 Pr.836 Torque setting filter 2 Pr.849 Analog input offset adjustment

- The time constant of the primary delay filter relative to external frequency command (analog input (terminal 1, 2, 4) signal) can be set.
 - Effective for filtering noise in the frequency setting circuit.
 - Increase the filter time constant if steady operation cannot be performed due to noise.
- A larger setting results in slower response. (The time constant can be set between approximately 5ms to 1s with the setting of 0 to 8.)
- Set the time constant of the primary delay filter relative to the external speed command (analog input command) using Pr.822 and Pr.832.
 - Set a large time constant when you want to delay the tracking of the speed command, when the analog input voltage fluctuates, etc.
- Set the time constant of the primary delay filter relative to the external torque command (analog input command) using Pr.826 and Pr.836.
 - Set a large time constant value when you want to delay the tracking of the torque command, when the analog input voltage fluctuates, etc.
- Pr.832 Speed setting filter 2 and Pr.836 Torque setting filter 2 are valid when a value other than "9999" is set and the RT signal is on.
- Setting Pr.849 provides frequency command by analog input (terminal 2) with offset and avoids frequency command to be given due to noise under 0 speed command.

Features
 Peripheral Devices
 Standard Specifications
 Outline Dimension Drawings
 Terminal Connection Diagram Terminal Specification Explanation
 Operation Panel
 Parameter List
 Explanations of Parameters
 Protective Functions
 Options
 Instructions
 Motor
 Compatibility
 Warranty
 Inquiry

- On the assumption that the Pr.849 setting 100% as 0, the offset voltage is offset as follows:
 100% < Pr.849...positive side
 100% > Pr.849...negative side

The offset voltage is found by the following formula.

$$\text{Offset voltage} = \left(\frac{\text{Voltage at 100\%}}{\text{(according to the Pr.73 setting)}} \times \frac{\text{Pr.849} - 100}{100} \right) \text{ [V]}$$

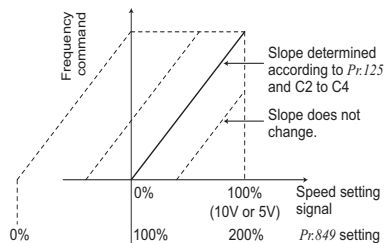

Pr.75 Reset selection, disconnected PU detection

Pr.75 Reset selection/disconnected PU detection/PU stop selection

You can select the reset input acceptance, disconnected PU (FR-DU07/FR-PU04/FR-PU07) connector detection function and PU stop function.

Pr.75 Setting	Reset Selection	Disconnected PU Detection	PU Stop Selection
0	Reset input normally enabled	If the PU is disconnected, operation will be continued as-is.	Pressing decelerates the motor to a stop only in the PU operation mode.
1	Reset input enabled only when the protective function is activated		
2	Reset input normally enabled	When the PU is disconnected, the inverter output is shut off.	Pressing decelerates the motor to a stop in any of the PU, external and communication operation modes.
3	Reset input enabled only when the protective function is activated		
14 (initial value)	Reset input normally enabled	If the PU is disconnected, operation will be continued as-is.	Pressing decelerates the motor to a stop in any of the PU, external and communication operation modes.
15	Reset input enabled only when the protective function is activated		
16	Reset input normally enabled	When the PU is disconnected, the inverter output is shut off.	
17	Reset input enabled only when the protective function is activated		

- Reset selection
 - You can select the operation timing of reset function (RES signal, reset command through communication) input.
- Disconnected PU detection
 - This function detects that the PU (FR-DU07/FR-PU04/FR-PU07) has been disconnected from the inverter for longer than 1s and causes the inverter to provide an alarm output (E.PUE) and come to an alarm stop.
- PU stop selection
 - In any of the PU operation, external operation and network operation modes, the motor can be stopped by pressing of the PU.

Pr.76 Output function of alarm code

Pr.76 Fault code output selection

At alarm occurrence, its description can be output as a 4-bit digital signal from the open collector output terminals. The alarm code can be read by a programmable controller, etc., and its corrective action can be shown on a display, etc.

Pr.76 Setting	Description
0 (initial value)	Without alarm code output
1	With alarm code output (refer to the table below)
2	Alarm code output at alarm occurrence only (refer to the table below)

- The following table indicates alarm codes to be output. (0: output transistor off, 1: output transistor on)

Operation Panel Indication (FR-DU07)	Output of Output Terminals				Alarm Code
	SU	IPF	OL	FU	
Normal*	0	0	0	0	0
E.OC1	0	0	0	1	1
E.OC2	0	0	1	0	2
E.OC3	0	0	1	1	3
E.OV1 to E.OV3	0	1	0	0	4
E.THM	0	1	0	1	5
E.THT	0	1	1	0	6
E.IPF	0	1	1	1	7
E.UVT	1	0	0	0	8
E.FIN	1	0	0	1	9
E.BE	1	0	1	0	A
E.GF	1	0	1	1	B
E.OHT	1	1	0	0	C
E.OLT	1	1	0	1	D
E.OPT	1	1	1	0	E
E.OP3	1	1	1	0	E
Other than the above	1	1	1	1	F

* When Pr.76 = "2", the output terminals output the signals assigned to Pr.191 to Pr.194

Pr.77 Prevention of parameter rewrite

Pr.77 Parameter write selection

You can select whether write to various parameters can be performed or not. Use this function to prevent parameter values from being rewritten by misoperation.

Pr.77 Setting	Description
0 (initial value)	Write is enabled only during a stop.
1	Parameter write is not enabled.
2	Parameter write is enabled in any operation mode regardless of operation status.

Pr.78 Prevention of reverse rotation of the motor

Pr.78 Reverse rotation prevention selection

This function can prevent reverse rotation fault resulting from the incorrect input of the start signal.











Pr.78 Setting	Description
0 (initial value)	Both forward and reverse rotations allowed
1	Reverse rotation disabled
2	Forward rotation disallowed

Pr. 79, 340

Operation mode selection

Pr.79 Operation mode selection Pr.340 Communication startup mode selection

- Used to select the operation mode of the inverter. Mode can be changed as desired between operation using external signals (external operation), operation from the PU (FR-DU07/FR-PU07/FR-PU04), combined operation of PU operation and external operation (external/PU combined operation), and network operation (when RS-485 terminals or a communication option is used).

Pr.79 Setting	Description	LED Indication :Off :On
0 (initial value)	External/PU switchover mode (Press  to switch between the PU and external operation mode.) External operation mode at power-on.	External operation mode  :On PU operation mode  :On
1	Fixed to PU operation mode	 :On
2	Fixed to external operation mode Operation can be performed by switching between the external and Net operation mode.	External operation mode  :On NET operation mode  :On
3	External/PU combined operation mode 1	
	Running frequency	Start signal
4	External/PU combined operation mode 2	
	Running frequency	Start signal
6	Switchover mode Switch among PU operation, external operation, and NET operation while keeping the same operation status.	PU operation mode  :On External operation mode  :On NET operation mode  :On
7	External operation mode (PU operation interlock) X12 signal ON Operation mode can be switched to the PU operation mode. (output stop during external operation) X12 signal OFF Operation mode can not be switched to the PU operation mode.	PU operation mode  :On External operation mode  :On

- Specify the operation mode at power on (Pr.340)
 - When power is switched on or when power comes back on after instantaneous power failure, the inverter can be started up in the network operation mode.
After the inverter has started up in the network operation mode, parameter write and operation can be performed from a program. Set this mode for communication operation using the inverter RS-485 terminals or communication option.
 - You can set the operation mode at power on (reset) according to the Pr.79 and Pr.340 settings.

Pr.340 Setting	Pr.79 Setting	Operation Mode at Power on, Power Restoration, Reset	Operation Mode Switchover
0 (initial value)	As set in Pr.79.		
1, 2 *1	0	NET operation mode	Switching among the external, PU, and NET operation mode is enabled *2
	1	PU operation mode	Fixed to PU operation mode
	2	NET operation mode	Switching between the PU and Net operation mode is enabled Switching to PU operation mode is disabled
	3, 4	External/PU combined operation mode	Operation mode switching is disabled
	6	NET operation mode	Switching among the external, PU, and NET operation mode is enabled while running.
	7	X12(MRS)signal ONNET operation mode	Switching among the external, PU, and NET operation mode is enabled *2
		X12(MRS)signal OFFExternal operation mode	Fixed to external operation mode (Forcibly switched to external operation mode.)
10, 12 *1	0	NET operation mode	Switching between the PU and NET operation mode is enabled *3
	1	PU operation mode	Fixed to PU operation mode
	2	NET operation mode	Fixed to NET operation mode
	3, 4	External/PU combined operation mode	Operation mode switching is disabled
	6	NET operation mode	Switching between the PU and NET operation mode is enabled while running *3
	7	External operation mode	Fixed to external operation mode (Forcibly switched to external operation mode.)

*1 The Pr.340 settings "2 or 12" is mainly used for communication operation using the inverter RS-485 terminals. When a value other than "9999" (selection of automatic restart after instantaneous power failure) is set in Pr.57 Restart coasting time, the inverter will resume the same operation state which was in before after power has been restored from an instantaneous power failure.

*2 The operation mode cannot be switched directly between the PU operation mode and network operation mode.

*3 Operation mode can be changed between the PU operation mode and network operation mode with  key of the operation panel (FR-DU07) and X65 signal.

- Features
- Peripheral Devices
- Standard Specifications
- Outline Dimension Drawings
- Terminal Connection Diagram Terminal Specification Explanation
- Operation Panel
- Parameter List
- Explanations of Parameters
- Protective Functions
- Options
- Instructions
- Motor
- Compatibility
- Warranty
- Inquiry

Pr 80, 81, 89, 451, 453, 454, 569, 800
Selection of control method and control mode

Magnetic flux Sensorless Vector

Pr.80 Motor capacity	Pr.81 Number of motor poles
Pr.89 Speed control gain (Advanced magnetic flux vector)	Pr.451 Second motor control method selection
Pr.453 Second motor capacity	Pr.454 Number of second motor poles
Pr.569 Second motor speed control gain	Pr.800 Control method selection

Advanced magnetic flux vector control can be selected by setting the capacity and the number of motors to be used in Pr.80 and Pr.81. When low speed torque and high accuracy and fast response control are necessary, select real sensorless vector control or vector control using Pr.800.

- What is real sensorless vector control?
This function enables vector control with a general-purpose motor without encoder.
- What is vector control?
Speed control, torque control and position control can be performed using a motor with encoder. (Plug-in option FR-A7AP is necessary.)

Parameter Number	Setting Range	Description		
80 453	0.4 to 55kW/0 to 3600kW*1	Set the applied motor capacity.		
	9999 (initial value)	V/F control		
81 454	2, 4, 6, 8, 10	Set the number of motor poles.		
	12, 14, 16, 18, 20	X18 signal*2-ON: V/F control	Set 10 + number of motor poles.	
	9999 (initial value)	V/F control		
800 451*3	0	Speed control	Vector control (FR-A7AP)	
	1	Torque control		
	2	MC signal*2-ON:torque MC signal*2-OFF:speed		
	3	Position control		
	4	MC signal*2-ON:position MC signal*2-OFF:speed		
	5	MC signal*2-ON:torque MC signal*2-OFF:position	Real sensorless vector control	
	9	Vector control test operation Test operation of vector control can be performed without connecting a motor.		
	10	Speed control		
	11	Torque control		
	12	MC signal*2-ON:torque MC signal*2-OFF:speed		
20 (initial value)	V/F control (advanced magnetic flux vector control)			

*1 The setting depends on the inverter capacity. (55K or less/75K or more)
 *2 Use Pr.178 to Pr.189 to assign the terminals used for the X18 and MC signal.
 *3 Only "10 to 12, 20, 9999" can be set in Pr.451.

- The motor speed fluctuation at load fluctuation can be adjusted using Pr.89 (Pr.569).
- Control method of the second motor can be selected using the RT signal.
- The Pr.22 function is changed according to the Pr.800 setting (stall prevention operation level/torque limit level).

Pr 82 to 84, 90 to 94, 96, 455 to 463, 684, 859, 860
Offline auto tuning

Magnetic flux Sensorless Vector

Pr.82 Motor excitation current	Pr.83 Rated motor voltage
Pr.84 Rated motor frequency	Pr.90 Motor constant (R1)
Pr.91 Motor constant (R2)	Pr.92 Motor constant (L1)
Pr.93 Motor constant (L2)	Pr.94 Motor constant (X)
Pr.96 Auto tuning setting/status	Pr.455 Second motor excitation current
Pr.456 Rated second motor voltage	Pr.457 Rated second motor frequency
Pr.458 Second motor constant (R1)	Pr.459 Second motor constant (R2)
Pr.460 Second motor constant (L1)	Pr.461 Second motor constant (L2)
Pr.462 Second motor constant (X)	Pr.463 Second motor auto tuning setting/status
Pr.684 Tuning data unit switchover	Pr.859 Torque current
Pr.860 Second motor torque current	

Offline auto tuning operation for automatic calculation of motor constants can be executed when using advanced magnetic flux vector control, real sensorless vector control and vector control.

Offline auto tuning is necessary when using real sensorless vector control.

- You can copy the online tuning data (motor constants) to another inverter using the PU (FR-DU07/FR-PU07).
- Even when motors (other manufacturer's motor, SF-JRC, etc.) other than Mitsubishi standard motor (SF-JR SF-HR 0.4kW or more), Mitsubishi constant-torque motor (SF-JRCA 4P, SF-HRCA 0.4kW to 55kW) and Mitsubishi vector control dedicated motor (SF-V5RU) are used or the wiring length is long, using the offline auto tuning function runs the motor with the optimum operating characteristics.
- Offline auto tuning conditions
 - A motor should be connected.
 - The motor capacity is equal to or one rank lower than the inverter capacity. (note that the capacity is 0.4kW or more)
 - The maximum frequency is 120Hz.
 - A high-slip motor, high-speed motor and special motor cannot be tuned.
- Note the following when "101" (offline auto tuning performed with motor running) is set in Pr.96 (Pr.463).
 - 1) Torque is not enough during tuning.
 - 2) The motor may be run at nearly its rated frequency (Pr. 84 setting) without any problem.
 - 3) The brake should be open.
 - 4) No external force is applied to rotate the motor.
- Even if "1" (tuning performed without motor running) is set in Pr.96 (Pr.463), the motor may run slightly. Therefore, fix the motor securely with a mechanical brake, or before tuning, make sure that there will be no problem in safety if the motor runs.

* This instruction must be followed especially in elevator.
 Note that if the motor runs slightly, tuning performance is unaffected.

Pr 89 ➔ Refer to the section about Pr. 80.

Pr. 95, 574

Online auto tuning Magnetic flux Sensorless Vector

Pr.95 Online auto tuning selection *Pr.574 Second motor online auto tuning*

When online auto tuning is selected, excellent torque accuracy is provided by temperature compensation even if the secondary resistance value of the motor varies with the rise of the motor temperature.

Select magnetic flux observer when performing vector control.

Pr.95, Pr.574 Setting	Description
0 (initial value)	Online auto tuning is not performed
1	Start-time tuning (at start-up)
2*	Magnetic flux observer (normal)

* Only Pr.95 can be set.

- Perform offline auto tuning before performing start-time tuning of the online auto tuning. Data needs to be calculated.
- For using start-time tuning in elevator, examine the utilization of a brake sequence for the brake opening timing at a start. Though the tuning ends in about a maximum of 500ms after a start, torque is not provided fully during that period. Therefore, note that there may be a possibility of drop due to gravity.
- For the SF-V5RU, SF-JR (with encoder) or SF-HRCA (with encoder), it is not necessary to perform offline auto tuning to select adaptive magnetic flux observer. (However, perform offline auto tuning when the wiring length is long.)

Pr. 96 ➔ Refer to the section about Pr. 82.

Pr. 100 to 109

Adjustable 5 points V/F V/F

<i>Pr.100 V/F1(first frequency)</i>	<i>Pr.101 V/F1(first frequency voltage)</i>
<i>Pr.102 V/F2(second frequency)</i>	<i>Pr.103 V/F2(second frequency voltage)</i>
<i>Pr.104 V/F3(third frequency)</i>	<i>Pr.105 V/F3(third frequency voltage)</i>
<i>Pr.106 V/F4(fourth frequency)</i>	<i>Pr.107 V/F4(fourth frequency voltage)</i>
<i>Pr.108 V/F5(fifth frequency)</i>	<i>Pr.109 V/F5(fifth frequency voltage)</i>

A dedicated V/F pattern can be made by freely setting the V/F characteristic between a startup and the base frequency and base voltage under V/F control (frequency voltage/frequency).

The torque pattern that is optimum for the machine's characteristic can be set.

- Set "2" in Pr.71 and voltage and frequency in Pr.100 to Pr.109 .
- When frequency values at each point are the same, write disable error (E r 1) appears. Set frequency and voltage within the range of Pr.3 Base frequency and Pr.19 Base frequency voltage .

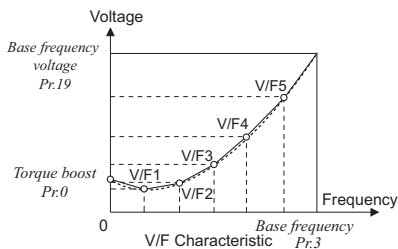

- When Pr.19 Base frequency voltage = "8888" or "9999", Pr.71 cannot be set to "2". When setting "2" in Pr.71, set the rated voltage value in Pr.19.

Pr. 110, 111 ➔ Refer to the section about Pr.7.

Pr. 112 ➔ Refer to the section about Pr.0.

Pr. 113 ➔ Refer to the section about Pr.3.

Pr. 114, 115 ➔ Refer to the section about Pr.22.

Pr. 116 ➔ Refer to the section about Pr.41.

When setting parameters, refer to the instruction manual (applied) and understand instructions.

Pr. 117 to 124, 331 to 337, 341 to 343, 539, 549

Communication initial setting

<i>Pr.117 PU communication station number</i>	<i>Pr.118 PU communication speed</i>
<i>Pr.119 PU communication stop bit length</i>	<i>Pr.120 PU communication parity check</i>
<i>Pr.121 Number of PU communication retries</i>	<i>Pr.122 PU communication check time interval</i>
<i>Pr.123 PU communication waiting time setting</i>	
<i>Pr.124 PU communication CR/LF selection</i>	
<i>Pr.331 RS-485 communication station number</i>	<i>Pr.332 RS-485 communication speed</i>
<i>Pr.333 RS-485 communication stop bit length</i>	<i>Pr.334 RS-485 communication parity check selection</i>
<i>Pr.335 RS-485 communication retry count</i>	<i>Pr.336 RS-485 communication check time interval</i>
<i>Pr.337 RS-485 communication waiting time setting</i>	<i>Pr.341 RS-485 communication CR/LF selection</i>
<i>Pr.342 Communication EEPROM write selection</i>	<i>Pr.343 Communication error count</i>
<i>Pr.539 Modbus-RTU communication check time interval</i>	<i>Pr.549 Protocol selection</i>

(1) Initial settings and specifications of RS-485 communication (Pr.117 to Pr.124, Pr.331 to Pr.337, Pr.341)

Used to perform required settings for RS-485 communication between the inverter and personal computer.

- There are two different communications: communication using the PU connector of the inverter and communication using the RS-485 terminals.
- You can perform parameter setting, monitoring, etc. using the Mitsubishi inverter protocol or Modbus-RTU protocol.
- To make communication between the personal computer and inverter, initialization of the communication specifications must be made to the inverter. Data communication cannot be made if the initial settings are not made or there is any setting error.

Pr. Number	Setting Range	Description	
117 331	0 to 31 (0 to 247)*1	Specify the inverter station number. Set the inverter station numbers when two or more inverters are connected to one personal computer.	
118 332	48, 96, 192, 384 (3, 6, 12, 24)*2	Set the communication speed. The setting value × 100 equals the communication speed. For example, the communication speed is 19200bps when the setting value is 192.	
119 333	0 1 (initial value) 10 11	Stop bit length	Data length
		1bit	8bit
		2bit	7bit
		1bit 2bit	
120 334	0 1 2 (initial value)	Without parity check With odd parity check With even parity check	
121 335	0 to 10	Set the permissible number of retries at occurrence of a data receive error. If the number of consecutive errors exceeds the permissible value, the inverter will come to an alarm stop.	
	9999	If a communication error occurs, the inverter will not come to an alarm stop.	
122 336	0	No PU connector communication. Communication with RS-485 terminals can be made, but the inverter will come to an alarm stop in the NET operation mode.	
	0.1 to 999.8s	Set the interval of communication check time. If a no-communication state persists for longer than the permissible time, the inverter will come to an alarm stop.	
	9999 (initial value)	No communication check	
123 337	0 to 150ms	Set the waiting time between data transmission to the inverter and response.	
	9999 (initial value)	Set with communication data.	
124 341	0	Without CR/LF	
	1 (initial value)	With CR	
	2	With CR/LF	

*1 When making communication through Modbus-RTU protocol with the RS-485 terminals, the setting range of Pr.331 within parenthesis is applied.

*2 The values in parenthesis are added to the setting range of Pr.332.

- Features
- Peripheral Devices
- Standard Specifications
- Outline Dimension Drawings
- Terminal Connection Diagram Terminal Specification Explanation
- Operation Panel
- Parameter List
- Explanations of Parameters
- Protective Functions
- Options
- Instructions
- Motor
- Compatibility
- Warranty
- Inquiry

- (2) **Communication EEPROM write selection (Pr. 342)**
 Parameters written via the inverter's PU connector, RS-485 terminals, or from the communication option can be written to the RAM. When performing parameter change frequently, set "1" in Pr.342.

(3) **Modbus-RTU communication specifications (Pr.343, Pr.539, Pr.549)**

Pr. Number	Setting Range	Description
343	—	Display the number of communication errors during Modbus-RTU communication. Reading only
539	0	Modbus-RTU communication can be made, but the inverter will come to an alarm stop in the NET operation mode.
	0.1 to 999.8s	Set the interval of communication check time. (same specifications as Pr. 122)
	9999	No communication check (signal loss detection)
549	0 (initial value)	Mitsubishi inverter (computer link operation) protocol
	1	Modbus-RTU protocol

* Modbus-RTU protocol is valid only for communication from the FR-485 terminals.

Pr. 125, 126, 241, C2 (902) to C7 (905), C12 (917) to C19 (920), C38 (932) to C41 (933)

Analog input frequency (speed) and torque/magnetic flux change and adjustment (calibration)

- Pr.125 Terminal 2 frequency setting gain frequency Pr.126 Terminal 4 frequency setting gain frequency
- Pr.241 Analog input display unit switchover
- C2(pr:902) Terminal 2 frequency setting bias frequency C4(Pr:903) Terminal 2 frequency setting gain
- C3(Pr:902) Terminal 2 frequency setting bias C4(Pr:903) Terminal 2 frequency setting gain
- C5(Pr:904) Terminal 4 frequency setting bias frequency C7(Pr:905) Terminal 4 frequency setting gain
- C6(Pr:904) Terminal 4 frequency setting bias C7(Pr:905) Terminal 4 frequency setting gain
- C12(Pr:917) Terminal 1 bias frequency (speed) C13(Pr:917) Terminal 1 bias (speed)
- C14(Pr:918) Terminal 1 gain frequency (speed) C15(Pr:918) Terminal 1 gain (speed)
- C16(Pr:919) Terminal 1 bias command (torque/magnetic flux)
- C17(Pr:919) Terminal 1 bias (torque/magnetic flux)
- C18(Pr:920) Terminal 1 gain command (torque/magnetic flux)
- C19(Pr:920) Terminal 1 gain (torque/magnetic flux)
- C38(Pr:932) Terminal 4 bias command (torque/magnetic flux)
- C39(Pr:932) Terminal 4 bias (torque/magnetic flux)
- C40(Pr:933) Terminal 4 gain command (torque/magnetic flux)
- C41(Pr:933) Terminal 4 gain (torque/magnetic flux)

• You can set the magnitude (slope) of the output frequency (speed, torque/magnetic flux) as desired in relation to the frequency setting signal (0 to 5VDC, 0 to 10V or 4 to 20mA).

(1) **Change the frequency (speed) at maximum analog input. (Pr.125, Pr.126, C14(Pr.918))**

Set a value in Pr.125(Pr.126, C14(Pr.918)) when changing only the frequency setting (gain) of the maximum analog input voltage (current). (Other calibration parameter settings need not be changed.)

(2) **Change the torque/magnetic flux at maximum analog input. (C18 (Pr.920), C40 (Pr.933))**

Set C18(Pr:920), C40(Pr:933) when changing only torque/magnetic flux command of the maximum analog input voltage (current). (Other calibration parameter settings need not be changed.)

(3) **Analog input bias/gain calibration (C2 (Pr.902) to C7 (Pr.905), C16 (Pr. 919) to C19 (Pr. 920), C38 (Pr. 932) to C41 (Pr. 933))**

The "bias" and "gain" functions are used to adjust the relationship between the input signal entered from outside the inverter to set the output frequency (torque/magnetic flux), e.g. 0 to 5V, 0 to 10V or 4 to 20mA, and the output frequency (torque/magnetic flux).

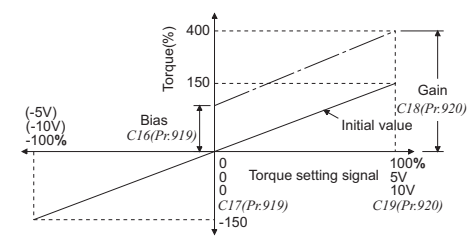
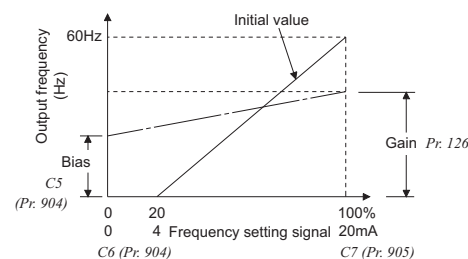
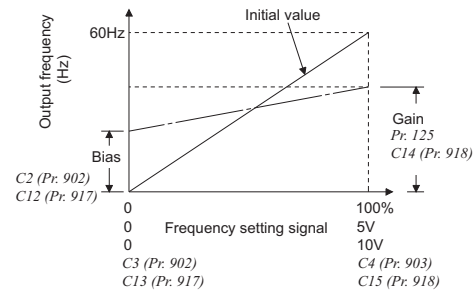

Calibration example of terminal 1

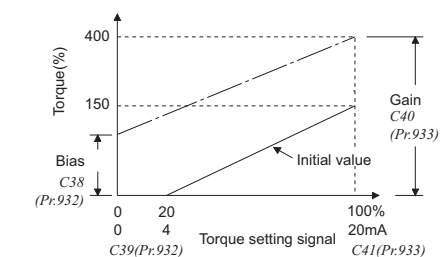

Calibration example of terminal 4

(4) **Analog input display unit changing (Pr.241)**

You can change the analog input display unit (%V/mA) for analog input bias/gain calibration.

Pr. 127 to 134, 575 to 577
PID control

- Pr.127 PID control automatic switchover frequency
- Pr.128 PID action selection
- Pr.129 PID proportional band
- Pr.130 PID integral time
- Pr.131 PID upper limit
- Pr.132 PID lower limit
- Pr.133 PID action set point
- Pr.134 PID differential time
- Pr.575 Output interruption detection time
- Pr.576 Output interruption detection level
- Pr.577 Output interruption cancel level

The inverter can be used to exercise process control, e.g. flow rate, air volume or pressure.

The terminal 2 input signal or parameter setting is used as a set point and the terminal 4 input signal used as a feedback value to constitute a feedback system for PID control.

· Pr.128 = "10, 11"(deviation value signal input)

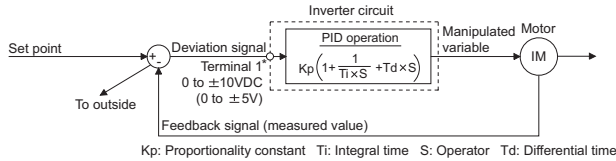

· Pr.128 = "20, 21"(measured value input)

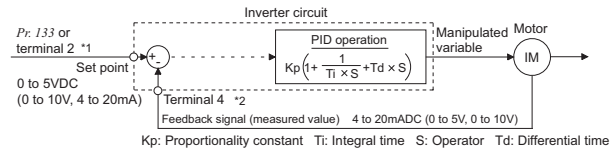

Pr. 135 to 139, 159
Switch between the inverter operation and commercial power-supply operation to use

- Pr.135 Electronic bypass sequence selection
- Pr.136 MC switchover interlock time
- Pr.137 Start waiting time
- Pr.138 Bypass selection at a fault
- Pr.139 Automatic switchover frequency from inverter to bypass operation
- Pr.159 Automatic switchover frequency range from bypass to inverter operation

The complicated sequence circuit for commercial power supply inverter switchover is built in the inverter. Hence, merely inputting the start, stop or automatic switchover selection signal facilitates the interlock operation of the switchover magnetic contactor.

Commercial operation can not be performed with the Mitsubishi vector motor (SF-V5RU).

Pr135 Setting	Description
0 (initial value)	Without commercial power-supply switchover sequence
1	With commercial power-supply switchover sequence

Sink logic type, Pr.185 = "7", Pr.192 = "17", Pr.193 = "18", Pr.194 = "19"

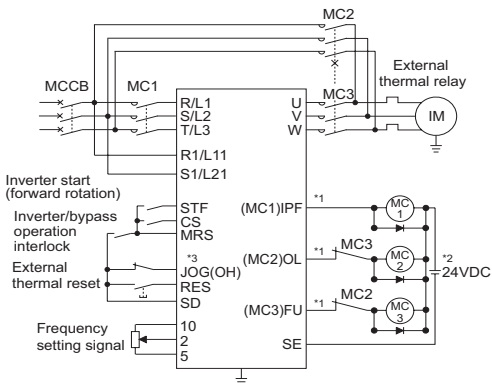

Commercial power-supply switchover sequence connection diagram

- *1 Take caution for the capacity of the sequence output terminal.
- *2 When connecting a DC power, insert a protective diode.
- *3 The used terminal changes according to the Pr.180 to Pr.189 (input terminal function selection) settings.

Pr. 140 to 143 ➔ Refer to the section about Pr.29.

Pr. 144 ➔ Refer to the section about Pr. 37.

Pr. 145
Parameter unit display language selection

Pr.145 PU display language selection

You can switch the display language of the parameter unit (FR-PU04/FR-PU07) to another.

Pr.145 setting	Description
0 (initial value)	Japanese
1	English
2	German
3	French
4	Spanish
5	Italian
6	Swedish
7	Finnish

Pr. 148, 149 ➔ Refer to the section about Pr.22.

Pr. 150 to 153, 166, 167
Detection of output current (Y12 signal)
detection of zero current (Y13 signal)

- Pr.150 Output current detection level
- Pr.151 Output current detection signal delay time
- Pr.152 Zero current detection level
- Pr.153 Zero current detection time
- Pr.166 Output current detection signal retention time
- Pr.167 Output current detection operation selection

The output current during inverter running can be detected to output at the output terminal.

(1) Output current detection (Y12 signal, Pr.150, Pr.151, Pr.166, Pr.167)

- The output current detection function can be used for excessive torque detection, etc.
- If the output current remains higher than the Pr.150 setting during inverter operation for longer than the time set in Pr.151, the output current detection signal (Y12) is output from the inverter's open collector or relay output terminal.

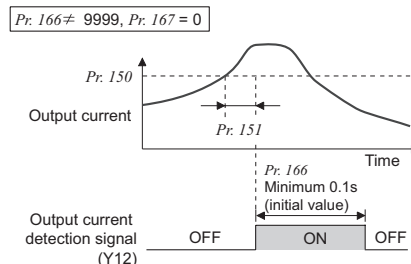

(2) Zero current detection (Y13 signal, Pr.152, Pr.153)

- If the output current remains lower than the Pr.152 setting during inverter operation for longer than the time set in Pr.153, the zero current detection (Y13) signal is output from the inverter's open collector or relay output terminal.

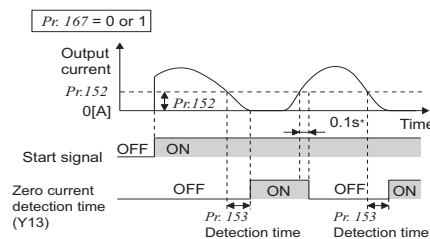

* Once turned on, the zero current detection time signal (Y13) is held on for at least 0.1s.

Pr. 154 ➔ Refer to the section about Pr.22.

Pr. 155
Selection of action conditions of the second function signal (RT) and third function signal (X9)

Pr.155 RT signal function validity condition selection

You can select the second (third) function using RT (X9) signal.
 You can also set the RT (X9) signal operation condition (reflection time).

Pr.155 Setting	Description
0 (initial value)	These functions are immediately made valid with on of the RT signal.
10	These functions are valid only during the RT signal is on and constant speed operation. (invalid during acceleration/deceleration)

· Functions which can be set as second and third function

Function	First Function Parameter	Second Function Parameter	Third Function Parameter
Torque boost	Pr:0	Pr:46	Pr:112
Base frequency	Pr:3	Pr:47	Pr:113
Acceleration time	Pr:7	Pr:44	Pr:110
Deceleration time	Pr:8	Pr:44, Pr:45	Pr:110, Pr:111
Electronic thermal O/L relay	Pr:9	Pr:51	—
Stall prevention	Pr:22	Pr:48, Pr:49	Pr:114, Pr:115
Applied motor	Pr:71	Pr:450	—
Motor constants	Pr:80 to Pr:84, Pr:89 Pr:90 to Pr:94, Pr:96	Pr:453 to Pr:457 Pr:569, Pr:458 to Pr:462, Pr:463	—
Motor control method	Pr:800	Pr:451	—
Analog input filter	Pr:822, Pr:826	Pr:832, Pr:836	—
Gain adjustment	Pr:820, Pr:821, Pr:824, Pr:825	Pr:830, Pr:831, Pr:834, Pr:835	—
Speed detection filter	Pr:823	Pr:833	—

Pr. 156, 157 ➤ Refer to the section about Pr.22.

Pr. 158 ➤ Refer to the section about Pr.52.

Pr. 159 ➤ Refer to the section about Pr.135.

Pr. 160, 172 to 174
User group function

Pr.160 User group read selection *Pr.172 User group registered display/batch clear*
Pr.173 User group registration *Pr.174 User group clear*

● Parameter which can be read from the operation panel and parameter unit can be restricted.
 The inverter is set to display all parameters with initial setting.

Pr.160 Setting	Description
0 (initial value)	All parameters can be displayed.
1	Only the parameters registered in the user group can be displayed.
9999	Only the simple mode parameters can be displayed.

- User group function (Pr.160, Pr.172 to Pr.174)
 - The user group function is designed to display only the parameters necessary for setting.
 - From among all parameters, a maximum of 16 parameters can be registered in the user group. When "1" is set in Pr.160, only parameters registered in the user group can be accessed for reading and writing. (The parameters not registered in the user group can not be read.)
 - To set a parameter in the user group, set its parameter number in Pr.173.
 - To delete a parameter from the user group, set its parameter number in Pr.174. To batch-delete the registered parameters, set Pr.172 to "9999".

Pr. 161
Operation selection of the operation panel

Pr.161 Frequency setting/key lock operation selection

You can use the setting dial of the operation panel (FR-DU07) like a potentiometer to perform operation.
 The key operation of the operation panel can be disabled.

Pr.161 Setting	Description	
0 (initial value)	Setting dial frequency setting mode	Key lock mode invalid
1	Setting dial potentiometer mode	Key lock mode invalid
10	Setting dial frequency setting mode	Key lock mode valid
11	Setting dial potentiometer mode	Key lock mode valid

Pr. 162 to 165 ➤ Refer to the section about Pr.57.

Pr. 166, 167 ➤ Refer to the section about Pr.150.

Pr. 168, 169 Parameter for manufacturer setting. Do not set.

Pr. 170, 171 ➤ Refer to the section about Pr.52.

Pr. 172 to 174 ➤ Refer to the section about Pr.160.

Pr. 178 to 189

Function assignment of input terminal

Pr.178 STF terminal function selection	Pr.179 STR terminal function selection
Pr.180 RL terminal function selection	Pr.181 RM terminal function selection
Pr.182 RH terminal function selection	Pr.183 RT terminal function selection
Pr.184 AU terminal function selection	Pr.185 JOG terminal function selection
Pr.186 CS terminal function selection	Pr.187 MRS terminal function selection
Pr.188 STOP terminal function selection	Pr.189 RES terminal function selection

Use these parameters to select/change the input terminal functions.

Pr.178 to Pr.189 Setting	Signal Name	Function	
		Pr.59 = 0 (initial value)	Pr.59 = 1, 2 *1
0	RL	Pr.59 = 0 (initial value)	Low-speed operation command
		Pr.59 = 1, 2 *1	Remote setting (setting clear)
		Pr.270 = 1, 3 *2	Stop-on contact selection 0
1	RM	Pr.59 = 0 (initial value)	Middle-speed operation command
		Pr.59 = 1, 2 *1	Remote setting (deceleration)
2	RH	Pr.59 = 0 (initial value)	High-speed operation command
		Pr.59 = 1, 2 *1	Remote setting (acceleration)
3	RT	Second function selection	
		Pr.270 = 1, 3 *2	Stop-on contact selection 1
4	AU	Terminal 4 input selection	
5	JOG	Jog operation selection	
6	CS	Selection of automatic restart after instantaneous power failure, flying start	
7	OH	External thermal relay input*3	
8	REX	15-speed selection (combination with three speeds RL, RM, RH)	
9	X9	Third function	
10	X10	Inverter operation enable signal (FR-HC/FR-CV connection)	
11	X11	FR-HC connection, instantaneous power failure detection	
12	X12	PU operation external interlock	
13	X13	External DC injection brake operation start	
14	X14	PID control valid terminal	
15	BRI	Brake opening completion signal	
16	X16	PU-external operation switchover	
17	X17	Load pattern selection forward rotation reverse rotation boost	
18	X18	V/F switchover (V/F control is exercised when X18 is on)	
19	X19	Load torque high speed frequency	
20	X20	S-pattern acceleration/deceleration C switching terminal	
22	X22	Orientation command	
23	LX	Pre-excitation (zero speed control/servo lock)	
24	MRS	Output stop	
25	STOP	Start self-holding selection	
26	MC	Control mode switchover	
27	TL	Torque limit selection	
28	X28	Start time tuning	
42	X42	Torque bias selection 1 *4	
43	X43	Torque bias selection 2 *4	
44	X44	P/PI control switchover	
60	STF	Forward rotation command (assigned to STF terminal (Pr.178) only)	
61	STR	Reverse rotation command (assigned to STR terminal (Pr.179) only)	
62	RES	Inverter reset	
63	PTC	PTC thermistor input (assigned to AU terminal (Pr.184) only)	
64	X64	PID forward/reverse action switchover	
65	X65	External/NET operation switchover	
66	X66	NET/PU operation switchover	
67	X67	Command source switchover	
68	NP	Conditional position pulse train sign*4	
69	CLR	Conditional position droop pulse clear*4	
70	X70	DC feeding operation permission	
71	X71	DC feeding cancel	
74	X74	Magnetic flux decay output shutoff signal	
9999	- - -	No function	

- *1 When Pr.59 Remote function selection= "1 or 2", the functions of the RL, RM and RH signals change as listed above.
- *2 When Pr.270 = "1 or 3", the functions of the RL and RT signals change as listed above.
- *3 The OH signal turns on when the relay contact "opens".
- *4 Available only when used with the FR-A7AP.

Pr. 190 to 196

Terminal assignment of output terminal

Pr.190 RUN terminal function selection	Pr.191 SU terminal function selection
Pr.192 IPF terminal function selection	Pr.193 OL terminal function selection
Pr.194 FU terminal function selection	Pr.195 ABC1 terminal function selection
Pr.196 ABC2 terminal function selection	

You can change the functions of the open collector output terminal and relay output terminal.

Pr.190 to Pr.196 Setting		Signal Name	Function
Positive logic	Negative logic		
0	100	RUN	Inverter running
1	101	SU	Up to frequency
2	102	IPF	Instantaneous power failure/undervoltage
3	103	OL	Overload alarm
4	104	FU	Output frequency detection
5	105	FU2	Second output frequency detection
6	106	FU3	Third output frequency detection
7	107	RBP	Regenerative brake prealarm
8	108	THP	Electronic thermal relay function prealarm
10	110	PU	PU operation mode
11	111	RY	Inverter operation ready
12	112	Y12	Output current detection
13	113	Y13	Zero current detection
14	114	FDN	PID lower limit
15	115	FUP	PID upper limit
16	116	RL	PID forward/reverse rotation output
17	—	MC1	Commercial power-supply switchover MC1
18	—	MC2	Commercial power-supply switchover MC2
19	—	MC3	Commercial power-supply switchover MC3
20	120	BOF	Brake opening request
25	125	FAN	Fan fault output
26	126	FIN	Heatsink overheat pre-alarm
27	127	ORA	Orientation in-position *
28	128	ORM	Orientation error *
30	130	Y30	Forward rotation output *
31	131	Y31	Reverse rotation output *
32	132	Y32	Regenerative status output *
33	133	RY2	Operation ready 2
34	134	LS	Low speed output
35	135	TU	Torque detection
36	136	Y36	In-position *
39	139	Y39	Start time tuning completion
41	141	FB	Speed detection
42	142	FB2	Second speed detection
43	143	FB3	Third speed detection
44	144	RUN2	Inverter running 2
45	145	RUN3	During inverter running and start command is on
46	146	Y46	During deceleration due to instantaneous power failure (retained until release)
47	147	PID	During PID control activated
64	164	Y64	During retry
70	170	SLEEP	During PID output suspension
84	184	RDY	Preparation ready signal *
85	185	Y85	DC current feeding
90	190	Y90	Life alarm
91	191	Y91	Alarm output 3 (power-off signal)
92	192	Y92	Energy saving average value updated timing
93	193	Y93	Current average monitor signal
94	194	ALM2	Alarm output 2
95	195	Y95	Maintenance timer signal
96	196	REM	Remote output
97	197	ER	Minor fault output 2
98	198	LF	Minor fault output
99	199	ALM	Alarm output
9999	—	—	No function

* Available only when used with the FR-A7AP.

- Pr. 232 to 239** ➤ Refer to the section about Pr. 4.
- Pr. 240** ➤ Refer to the section about Pr. 72.
- Pr. 241** ➤ Refer to the section about Pr. 125.

Features

Peripheral Devices

Standard Specifications

Outline Dimension Drawings

Terminal Connection Diagram Terminal Specification Explanation

Operation Panel

Parameter List

Explanations of Parameters

Protective Functions

Options

Instructions

Motor

Compatibility

Warranty

Inquiry

Pr. 242, 243 ➔ Refer to the section about *Pr. 73*.

Pr. 244

Increase cooling fan life

Pr.244 Cooling fan operation selection

You can control the operation of the cooling fan (200V class 1.5K or more, 400V class 2.2K or more) built in the inverter.

Pr.244 Setting	Description
0	Operates at power on Cooling fan on/off control invalid (the cooling fan is always on in power-on status)
1 (initial value)	Cooling fan on/off control valid The fan is always on while the inverter is running. During a stop, the inverter status is monitored and the fan switches on-off according to the temperature.

Pr. 245 to 247

Slip compensation V/F

Pr.245 Rated slip *Pr.246 Slip compensation time constant*
Pr.247 Constant-power range slip compensation selection

The inverter output current may be used to assume motor slip to keep the motor speed constant.

Pr. 250

Selection of motor stopping method and start signal

Pr.250 Stop selection

Used to select the stopping method (deceleration to a stop or coasting) when the start signal turns off.

Used to stop the motor with a mechanical brake, etc. together with switching off of the start signal.

You can also select the operations of the start signals (STF/STR).

Pr.250 Setting	Description	
	Start signal (STF/STR)	Stop operation
0 to 100s	STF signal: Forward rotation start STR signal: Reverse rotation start	The motor is coasted to a stop when the preset time elapses after the start signal is turned off.
1000s to 1100s	STF signal: Start signal STR signal: Forward/reverse signal	
9999	STF signal: Forward rotation start STR signal: Reverse rotation start	When the start signal is turned off, the motor decelerates to stop.
8888	STF signal: Start signal STR signal: Forward/reverse signal	

When "9999 (initial value) or "8888" is set in *Pr.250*

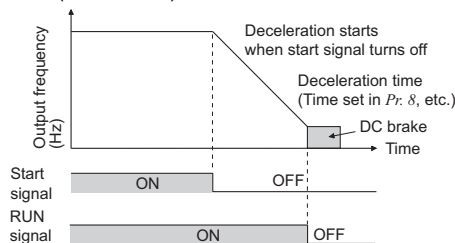

When a value other than "9999 (initial value) or "8888" is set in *Pr.250*

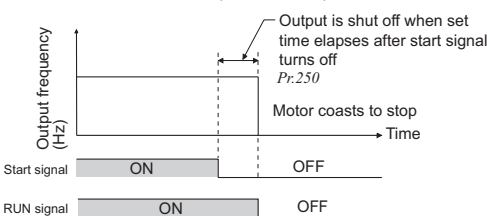

Pr. 251, 872

Input/output phase failure protection selection

Pr.251 Output phase loss protection selection
Pr.872 Input phase loss protection selection

You can disable the output phase failure protection function that stops the inverter output if one of the inverter output side (load side) three phases (U, V, W) opens.

The input phase failure protection selection of the inverter input side (R, S, T) can be made valid.

Pr. Number	Setting Range	Description
251	0	Without output phase failure protection
	1 (initial value)	With output phase failure protection
872	0 (initial value)	Without input phase failure protection
	1	With input phase failure protection

Pr. 252, 253 ➔ Refer to the section about *Pr. 73*.

Pr. 255 to 259

Display of the life of the inverter parts

Pr.255 Life alarm status display *Pr.256 Inrush current limit circuit life display*
Pr.257 Control circuit capacitor life display *Pr.258 Main circuit capacitor life display*
Pr.259 Main circuit capacitor life measuring

Degrees of deterioration of main circuit capacitor, control circuit capacitor or inrush current limit circuit and cooling fan can be diagnosed by monitor.

When any part has approached the end of its life, an alarm can be output by self diagnosis to prevent a fault.

(Use the life check of this function as a guideline since the life except the main circuit capacitor is calculated theoretically.)

Pr. Number	Setting Range	Description
255	(0 to 15)	Display whether the control circuit capacitor, main circuit capacitor, cooling fan, and each parts of the inrush current limit circuit has reached the life alarm output level or not. Reading only
256	(0 to 100%)	Display the deterioration degree of the inrush current limit circuit. Reading only
257	(0 to 100%)	Display the deterioration degree of the control circuit capacitor. Reading only
258	(0 to 100%)	Display the deterioration degree of the main circuit capacitor. Reading only The value measured by <i>Pr.259</i> is displayed.
259	0, 1	Setting "1" and turning the power supply off starts the measurement of the main circuit capacitor life. When the <i>Pr.259</i> value is "3" after powering on again, the measuring is completed. Read the deterioration degree in <i>Pr.258</i> .

Pr. 261 to 266, 294

Operation at instantaneous power failure

- Pr.261 Power failure stop selection
- Pr.262 Subtracted frequency at deceleration start
- Pr.263 Subtraction starting frequency
- Pr.264 Power-failure deceleration time 1
- Pr.265 Power-failure deceleration time 2
- Pr.266 Power-failure deceleration time switchover frequency
- Pr.294 UV avoidance voltage gain

When a power failure or undervoltage occurs, the inverter can be decelerated to a stop or can be decelerated and re-accelerated to the set frequency.

Pr. Number	Setting Range	Description
261	0(initial value)	Coasting to stop When undervoltage or power failure occurs, the inverter output is shut off.
	1	Without UV avoidance When undervoltage or a power failure occurs, the inverter can be decelerated to a stop.
	11	With UV avoidance
	2	Without UV avoidance
262	0 to 20Hz	When undervoltage or a power failure occurs, the inverter can be decelerated to a stop. If power is restored during a power failure, the inverter accelerates again.
		With UV avoidance
263	0 to 120Hz	Normally operation can be performed with the initial value unchanged. But adjust the frequency according to the magnitude of the load specifications (moment of inertia, torque).
		When output frequency \geq Pr.263 Decelerate from the speed obtained from output frequency minus Pr.262. When output frequency \leq Pr.263 Decelerate from output frequency
264	0 to 3600s/360s *	Set a deceleration slope down to the frequency set in Pr.266.
265	0 to 3600s/360s *	Set a deceleration slope below the frequency set in Pr.266.
		9999 Same slope as in Pr.264
266	0 to 400Hz	Set the frequency at which the deceleration slope is switched from the Pr.264 setting to the Pr.265 setting.
294	0 to 200%	Adjust response level at UV avoidance operation. A larger setting will improve responsiveness to the bus voltage change. Since the regeneration amount is large when the inertia is large, decrease the setting value.

* When the setting of Pr.21 Acceleration/deceleration time increments is "0" (initial value), the setting range is "0 to 3600s" and setting increments are "0.1s" and when the setting is "1", the setting range is "0 to 360s" and the setting increments are "0.01s".

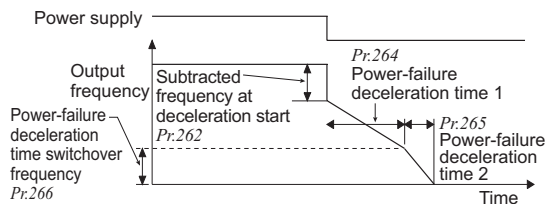

(1) Power failure stop mode (Pr.261="1" "11")

If power is restored during power failure deceleration, deceleration to a stop is continued and the inverter remains stopped. To restart, turn off the start signal once, then turn it on again.

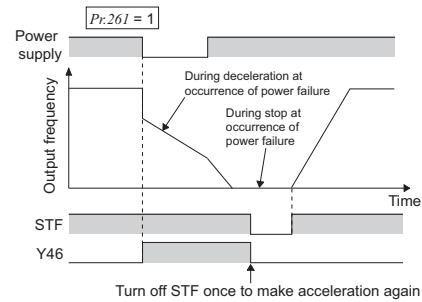

(2) Original operation continuation at instantaneous power failure function (Pr.261="2" "12")

When power is restored during deceleration after a power failure, acceleration is made again up to the set frequency. When this function is used in combination with the automatic restart after instantaneous power failure operation, deceleration can be made at a power failure and acceleration can be made again after power restoration.

When power is restored after a stop by deceleration at an instantaneous power failure, automatic restart operation is performed if automatic restart after instantaneous power failure has been selected (Pr.57 \neq "9999")

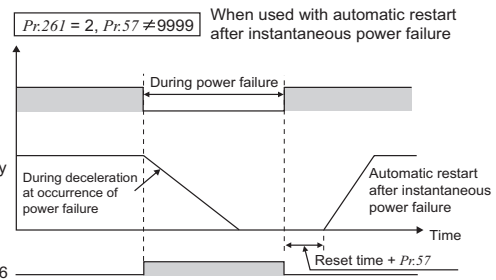
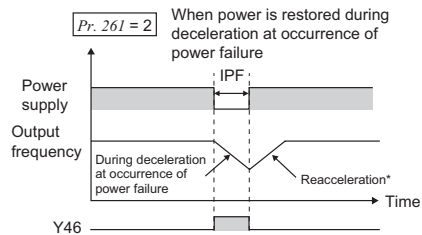

Pr. 267 ➤ Refer to the section about Pr. 73.

Pr. 268 ➤ Refer to the section about Pr.52.

Pr. 269 Parameter for manufacturer setting. Do not set.

Pr. 270 to 274, 4, 5
Load torque high speed frequency control

- Pr.270 Stop-on contact/load torque high-speed frequency control selection
- Pr.271 High-speed setting maximum current
- Pr.272 Middle-speed setting minimum current
- Pr.273 Current averaging range
- Pr.274 Current averaging filter time constant
- Pr.4 Multi-speed setting (high speed)
- Pr.5 Multi-speed setting (middle speed)

This function is designed to increase speed automatically under light load, for example to minimize the incoming/outgoing time in a multi-story parking lot. More specifically, the magnitude of the load is judged according to the average current at a certain time after starting to perform operation at higher than the preset frequency under light load.

Pr.270 Setting	Description
0 (initial value)	Without stop-on contact control and load torque high-speed frequency control
1	Stop-on contact control
2	Load torque high speed frequency control
3	Stop-on contact + load torque high speed frequency control

- Set "2 or 3" in Pr.270 to set the current value, averaging range, etc when the load torque high speed frequency control is selected.
- When the X19 signal (load detection high-speed frequency function selection) is turned on to start operation, the inverter automatically varies the maximum frequency between Pr.4 Multi-speed setting (high speed) and Pr.5 settings according to the average current flowing during acceleration from half of the frequency of the Pr.5 Multi-speed setting (middle speed) setting to the frequency set in Pr.5.

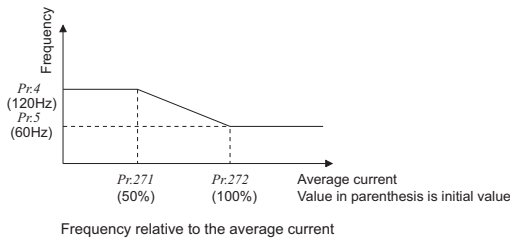

Pr. Number	Setting Range	Description
4	0 to 400Hz	Set the higher-speed frequency.
5	0 to 400Hz	Set the lower-speed frequency.
271	0 to 220%	Set the upper and lower limits of the current at high and middle speeds.
272	0 to 220%	
273	0 to 400Hz	Average current during acceleration from (Pr.273 × 1/2)Hz to (Pr.273)Hz can be achieved.
	9999	Average current during acceleration from (Pr.5 × 1/2)Hz to (Pr.5)Hz is achieved.
274	1 to 4000	Set the time constant of the primary delay filter relative to the output current. (The time constant[ms] is 0.75 × Pr.274 and the factory setting is 12ms.) A larger setting provides higher stability but poorer response.

Pr. 270, 275, 276, 6
Stop-on contact control Magnetic flux Sensorless

- Pr.270 Stop-on contact/load torque high-speed frequency control selection
- Pr.275 Stop-on contact excitation current low-speed multiplying factor
- Pr.276 PWM carrier frequency at stop-on contact
- Pr.6 Multi-speed setting (low speed)

To ensure accurate positioning at the upper limit etc. of an elevator, stop-on-contact control causes a mechanical brake to be closed while the motor is developing a holding torque to keep the load in contact with a mechanical stopper etc. This function suppresses vibration which is liable to occur when the load is stopped upon contact in vertical motion applications, ensuring steady precise positioning.

Pr.270 Setting	Description
0 (initial value)	Without stop-on contact control and load torque high-speed frequency control
1	Stop-on contact control
2	Load torque high speed frequency control
3	Stop-on contact + load torque high speed frequency control

- Select either real sensorless vector control or advanced magnetic flux vector control. When both the RT and RL signals are switched on, the inverter enters the stop-on contact mode, in which operation is performed at the frequency set in Pr.6 Multi-speed setting (low speed) independently of the preceding speed.

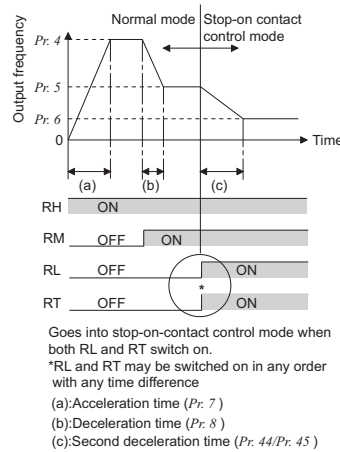

Pr. Number	Setting Range	Description
6	0 to 400Hz	Set the output frequency for stop-on-contact control. The frequency should be as low as possible (about 2Hz). If it is set to more than 30Hz, the operating frequency will be 30Hz. When performing stop-on-contact control during encoder feedback control, encoder feedback control is made invalid due to a mode shift to the stop-on-contact control mode.
		Set the stall prevention operation level for stop-on-contact when using under advanced magnetic flux vector control. (Use the Pr.22 setting value under real sensorless vector control.)
48	0 to 200%	Set the stall prevention operation level for stop-on-contact when using under advanced magnetic flux vector control. (Use the Pr.22 setting value under real sensorless vector control.)
275	0 to 1000%	Usually set a value between 130% and 180%. Set the force (holding torque) for stop-on-contact control.
	9999	No compensation.
276	0 to 9/0 to 4 *	Set a PWM carrier frequency for stop-on-contact control. For real sensorless vector control, carrier frequency is always 2kHz when a setting value is 0 to 5 and always 6kHz when a setting value is 6 to 9. (Valid at the output frequency of 3Hz or less.)
	9999	As set in Pr.72 PWM frequency selection.

* Differ according to capacities. (55K or less/75K or more)

Pr. 278 to 285, 292
Brake sequence function
 Magnetic flux Sensorless Vector

Pr.278 Brake opening frequency	Pr.279 Brake opening current
Pr.280 Brake opening current detection time	Pr.281 Brake operation time at start
Pr.282 Brake operation frequency	Pr.283 Brake operation time at stop
Pr.284 Deceleration detection function selection	Pr.285 Overspeed detection frequency
Pr.292 Automatic acceleration/deceleration	

This function is used to output from the inverter the mechanical brake opening completion signal timing signal in vertical lift and other applications.

This function prevents the load from dropping with gravity at a start due to the operation timing error of the mechanical brake or an overcurrent alarm from occurring at a stop, ensuring secure operation.

<Operation example>

- **At start:** When the start signal is input to the inverter, the inverter starts running. When the internal speed command reaches the value set in Pr.278 and the output current is not less than the value set in Pr.279, the inverter outputs the brake opening request signal (BOF) after the time set in Pr.280 has elapsed. When the time set in Pr.281 elapses after the brake opening completion signal (BRI) was activated, the inverter increases the output frequency to the set speed.
- **At stop:** When the speed has decreased to the frequency set in Pr.282, the brake opening request signal (BOF) is turned off. When the time set in Pr.283 elapses after the brake operation confirmation signal (BRI) was activated, the inverter output is switched off.
 - * If Pr.292 = "8" (mechanical brake opening completion signal not input), this time is the time after the brake opening request signal is output.

1) Pr.292 = "7" (brake opening completion signal input)

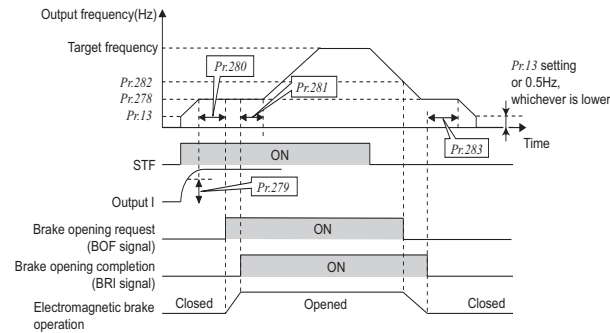

2) Pr.292 = "8" (brake opening completion signal not input)

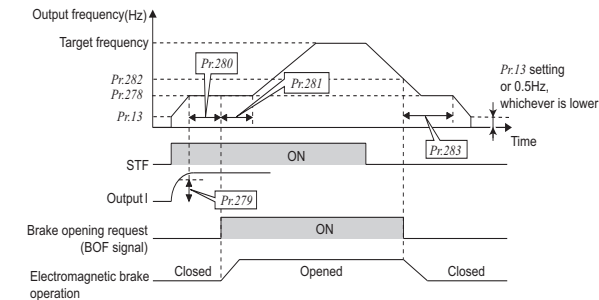

Pr. Number	Setting Range	Description
278	0 to 30Hz	Set to the rated slip frequency of the motor + about 1.0Hz. This parameter may be only set if Pr.278 ≤ Pr.282.
279	0 to 220%	Generally, set this parameter to about 50 to 90%. If the setting is too low, the load is liable to drop due to gravity at start. Suppose that the rated inverter current is 100%.
280	0 to 2s	Generally, set this parameter to about 0.1 to 0.3s.
281	0 to 5s	Pr.292 = 7: Set the mechanical delay time until the brake is loosened. Pr.292 = 8: Set the mechanical delay time until the brake is loosened+about 0.1 to 0.2s.
282	0 to 30Hz	At this frequency, the brake opening request signal (BOF) is switched off. Generally, set this parameter to the Pr.278 setting + 3 to 4Hz. This parameter may only be set if Pr.282 ≥ Pr.278.
283	0 to 5s	Pr.292 = 7: Set the mechanical delay time until the brake is closed + 0.1s. Pr.292 = 8: Set the mechanical delay time until the brake is closed + 0.2 to 0.3s.
284	0 (initial value)	Deceleration is not detected.
	1	If deceleration is not normal during deceleration operation, the inverter alarm (E.MB2) is provided to shut off the output and turn off the brake opening request signal (BOF).
285	0 to 30Hz	When brake sequence function is made valid under encoder feedback control If (detected frequency) - (output frequency) > Pr.285 the inverter alarm (E.MB1) is provided to shut off the output and turn off the brake opening request signal (BOF).
	9999 (initial value)	Overspeed is not detected.
292	0, 1, 3, 5 to 8, 11	Brake sequence function is made valid when a setting is "7" or "8".

Pr. 285, 853
Speed deviation excess detection Vector

Pr.285 Speed deviation excess detection frequency	Pr.853 Speed deviation time
---	-----------------------------

- If the difference (absolute value) between the speed command value and actual speed exceeds the Pr. 285 Speed deviation excess detection frequency setting for longer than the time set in Pr. 853 Speed deviation time during speed control under vector control, speed deviation excessive occurs and error "E. OSD" appears, resulting in a stop.

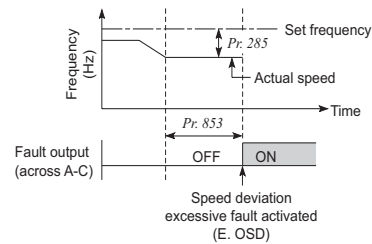

- Features
- Peripheral Devices
- Standard Specifications
- Outline Dimension Drawings
- Terminal Connection Diagram Terminal Specification Explanation
- Operation Panel
- Parameter List
- Explanations of Parameters
- Protective Functions
- Options
- Instructions
- Motor
- Compatibility
- Warranty
- Inquiry

Pr. 286 to 288

Drrop control Magnetic flux Sensorless Vector

Pr.286 Droop gain *Pr.287 Droop filter time constant*
Pr.288 Droop function activation selection

This function is designed to balance the load in proportion to the load torque to provide the speed drooping characteristic. This function is effective for balancing the load when using multiple inverters

Pr. Number	Setting Range	Description
286	0 (initial value)	Droop control is invalid
	0.1 to 100%	Set the drooping amount at the rated torque as a percentage with respect to the rated motor frequency.
287	0.00 to 1.00s	Set the time constant of the filter applied on the torque amount current.
288	Advanced magnetic flux vector control	
	Real sensor less vector / vector control	
	0 (initial value), 10	Droop control is not exercised during acceleration/deceleration. (When Pr.288 = 10, droop compensation amount is determined using the motor speed as reference.)
	1, 11	Droop control is always exercised during operation. (with 0 limit) (When Pr.288 = 11, droop compensation amount is determined using the motor speed as reference.)
	2	Droop control is always exercised during operation. (without 0 limit)

- Droop control
This control is valid when a value other than "0" is set in Pr.286 under advanced magnetic flux vector control, real sensorless vector control and vector control. The maximum droop compensation frequency is 120Hz.

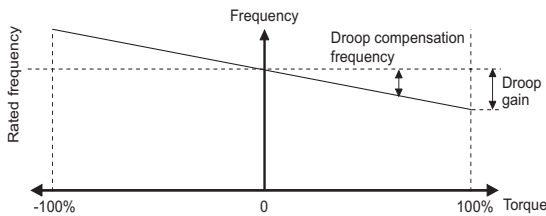

Pr. 291, 384 to 386

Pulse train I/O

Pr.291 Pulse train I/O selection *Pr.384 Input pulse division scaling factor*
Pr.385 Frequency for zero input pulse *Pr.386 Frequency for maximum input pulse*

The inverter speed can be set by inputting pulse train from terminal JOG. In addition, pulse train can be output as open collector from terminal FM. Synchronous speed operation of inverters can be performed by combining pulse train I/O.

Pr.291 Setting	Input	Output
0 (initial value)	JOG terminal	FM output
1	Pulse train input	FM output
10	JOG terminal	Pulse train output (50%Duty)
11	Pulse train input	
20	JOG terminal	Pulse train output (ON width is always same)
21	Pulse train input	
100	Pulse train input	Pulse train output (ON width is always same)*

* The inverter outputs the signal input as pulse train as it is regardless of the Pr.54 setting.

- Change the frequency at pulse train input. (Pr.385, Pr.386)

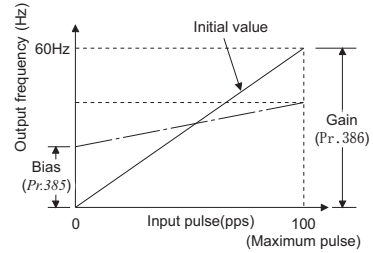

- Calculation method of input pulse division scaling factor (Pr.384)
Maximum number of input pulses (PPS)=Pr.384 × 400
(maximum permissible pulses=100kpps)
- When Pr.419 Position command source selection ="2" (conditional pulse train position command), JOG terminal serves as conditional position pulse train input terminal regardless of the Pr.291 Pulse train I/O selection setting.

Pr. 292, 293 ➔ Refer to the section about Pr.61.

Pr. 294 ➔ Refer to the section about Pr.261.

Pr. 299 ➔ Refer to the section about Pr.57.

Pr. 331 to 337 ➔ Refer to the section about Pr.117.

Pr. 338, 339, 550, 551

Operation command source and speed command source during communication operation

Pr.338 Communication operation command source *Pr.339 Communication speed command source*
Pr.550 NET mode operation command source selection
Pr.551PU mode operation command source selection

When the RS-485 terminals or communication option is used, the external operation command and speed command can be made valid. Operation command source in the PU operation mode can be selected.

Pr. Number	Setting Range	Description
338	0 (initial value)	Operation command source communication
	1	Operation command source external
339	0 (initial value)	Speed command source communication
	1	Speed command source external (Frequency setting from communication is invalid, terminal 2 and 1 setting from external is valid)
	2	Speed command source external (Frequency setting from communication is valid, terminal 2 and 1 setting from external is invalid)
550*	0	Communication option is valid
	1	RS-485 terminals are valid
	9999 (initial value)	Automatic recognition of the communication option Normally, the RS-485 terminals are valid. When a communication option is mounted, the communication option is valid.
551*	1	Select the RS-485 terminals as the PU operation mode control source
	2 (initial value)	Select the PU connector as the PU operation mode control source
	3	Select the USB connector as the PU operation mode control source

* Pr.550 and Pr.551 are always write-enabled.

Pr. 340 ➔ Refer to the section about Pr.79.

Pr. 341 to 343 ➔ Refer to the section about Pr.117.

Pr. 350 to 366, 369, 393, 396 to 399
Orientation control
 V/F Magnetic flux Vector

Pr.350 Stop position command selection	Pr.351 Orientation speed
Pr.352 Creep speed	Pr.353 Creep switchover position
Pr.354 Position loop switchover position	Pr.355 DC injection brake start position
Pr.356 Internal stop position command	Pr.357 Orientation in-position zone
Pr.358 Servo torque selection	Pr.359 Encoder rotation direction
Pr.360 16 bit data selection	Pr.361 Position shift
Pr.362 Orientation position loop gain	Pr.363 Completion signal output delay time
Pr.364 Encoder stop check time	Pr.365 Orientation limit
Pr.366 Recheck time	Pr.369 Number of encoder pulses
Pr.393 Orientation selection	Pr.396 Orientation speed gain (P term)
Pr.397 Orientation speed integral time	Pr.398 Orientation speed gain (D term)
Pr.399 Orientation deceleration ratio	

This function is used with a position detector (encoder) installed to the spindle of a machine tool, etc. to allow a rotation shaft to be stopped at the specified position (oriented).

- Plug-in option FR-A7AP is necessary.
- Internal stop position command
 When "0" is set in Pr.350 Stop position command selection, the inverter operates in the internal stop position command mode. In the internal stop position command mode, the setting value of Pr.356 Internal stop position command becomes a stop position.
- External stop position command
 When 1 is set in Pr.350 Stop position command selection and the option FR-A7AX is mounted, set a stop position using 16-bit data.
- Action time chart

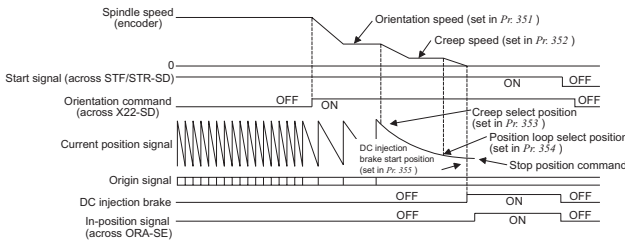

Pr. 359, 367 to 369
Encoder feedback control
 V/F Magnetic flux

Pr.359 Encoder rotation direction	Pr.367 Speed feedback range
Pr.368 Feedback gain	Pr.369 Number of encoder pulses

This controls the inverter output frequency so that the motor speed is constant to the load variation by detecting the motor speed with the speed detector (encoder) to feed it back to the inverter.

- Option FR-A7AP is necessary.
- Set the rotation direction of the encoder using Pr.359 Encoder rotation direction and Pr.369 Number of encoder pulses.
- When a value other than "9999" is set in Pr.367 Speed feedback range, encoder feedback control is valid. Using the set point (frequency at which stable speed operation is performed) as reference, set the higher and lower setting range. Normally, set the frequency converted from the slip amount (r/min) of the rated motor speed (rated load). If the setting is too large, response becomes slow.

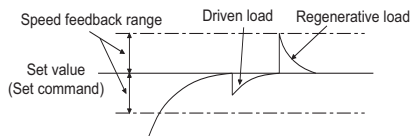

- Set Pr.368 Feedback gain when the rotation is unstable or response is slow.

Pr.368 Setting	Description
Pr.368 > 1	Although the response becomes faster, overcurrent or unstable rotation is liable to occur.
1 < Pr.368	Although the response becomes slower, the motor rotation becomes stable.

Pr. 374
Overspeed detection
 V/F Magnetic flux Vector

Pr.374 Overspeed detection level

When the motor speed reaches or exceeds the speed set in Pr.374 during encoder feedback control or vector control, overspeed (E.OS) occurs and stops the inverter output.

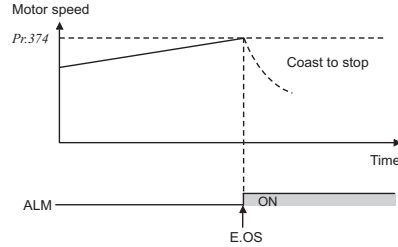

Pr. 376
Encoder signal cable breakage detection
 V/F Magnetic flux Vector

Pr.376 Encoder signal loss detection enable/disable selection

When the cable of the encoder signal is broken during encoder feedback control, orientation control, or vector control, open cable detection (E.ECT) is activated to stop the inverter output.

- Pr. 380 to 383 ➤ Refer to the section about Pr.29.
- Pr. 384 to 386 ➤ Refer to the section about Pr.291.

Features
 Peripheral Devices
 Standard Specifications
 Outline Dimension Drawings
 Terminal Connection Diagram Terminal Specification Explanation
 Operation Panel
 Parameter List
 Explanations of Parameters
 Protective Functions
 Options
 Instructions
 Motor
 Compatibility
 Warranty
 Inquiry

Pr. 419, 464 to 494
Conditional position feed by contact input
 Vector

Pr.419 Position command source selection	Pr.464 Digital position control sudden stop deceleration time
Pr.465 First position feed amount lower 4 digits	Pr.466 First position feed amount upper 4 digits
Pr.467 Second position feed amount lower 4 digits	Pr.468 Second position feed amount upper 4 digits
Pr.469 Third position feed amount lower 4 digits	Pr.470 Third position feed amount upper 4 digits
Pr.471 Fourth position feed amount lower 4 digits	Pr.472 Fourth position feed amount upper 4 digits
Pr.473 Fifth position feed amount lower 4 digits	Pr.474 Fifth position feed amount upper 4 digits
Pr.475 Sixth position feed amount lower 4 digits	Pr.476 Sixth position feed amount upper 4 digits
Pr.477 Seventh position feed amount lower 4 digits	Pr.478 Seventh position feed amount upper 4 digits
Pr.479 Eighth position feed amount lower 4 digits	Pr.480 Eighth position feed amount upper 4 digits
Pr.481 Ninth position feed amount lower 4 digits	Pr.482 Ninth position feed amount upper 4 digits
Pr.483 Tenth position feed amount lower 4 digits	Pr.484 Tenth position feed amount upper 4 digits
Pr.485 Eleventh position feed amount lower 4 digits	Pr.486 Eleventh position feed amount upper 4 digits
Pr.487 Twelfth position feed amount lower 4 digits	Pr.488 Twelfth position feed amount upper 4 digits
Pr.489 Thirteenth position feed amount lower 4 digits	Pr.490 Thirteenth position feed amount upper 4 digits
Pr.491 Fourteenth position feed amount lower 4 digits	Pr.492 Fourteenth position feed amount upper 4 digits
Pr.493 Fifteenth position feed amount lower 4 digits	Pr.494 Fifteenth position feed amount upper 4 digits

Inputting the number of pulses (positions) in the parameters and setting multi-speed and forward (reverse) commands enable position control during servo operation. This position feed function does not return to the home position.

- Set position command using any two of Pr. 465 to Pr. 494 (position feed amount).

Resolution of encoder × speed × 4

(When stopping the motor after 100 rotations using the FR-V5RU)
 2048 (pulse/rev) × 100 (speed) × 4 = 819200 (feed amount)

Setting of the first feed amount 819200

Pr.466 (upper) = "0081" Pr.465 (lower) = "9200" (decimal)

<Position feed data setting parameters>

Parameter	Name	(lower digits) (upper digits)	Selection Method				Position Feed Speed
			RE X	RH	RM	RL	
465	First position feed amount	(lower digits)	OFF	ON	OFF	OFF	High speed (Pr.4)
466		(upper digits)	OFF	ON	OFF	OFF	
467	Second position feed amount	(lower digits)	OFF	OFF	ON	OFF	Middle speed (Pr.5)
468		(upper digits)	OFF	OFF	ON	OFF	
469	Third position feed amount	(lower digits)	OFF	OFF	OFF	ON	Low speed (Pr.6)
470		(upper digits)	OFF	OFF	OFF	ON	
471	Fourth position feed amount	(lower digits)	OFF	OFF	ON	ON	Speed 4 (Pr.24)
472		(upper digits)	OFF	OFF	ON	ON	
473	Fifth position feed amount	(lower digits)	OFF	ON	OFF	ON	Speed 5 (Pr.25)
474		(upper digits)	OFF	ON	OFF	ON	
475	Sixth position feed amount	(lower digits)	OFF	ON	ON	OFF	Speed 6 (Pr.26)
476		(upper digits)	OFF	ON	ON	OFF	
477	Seventh position feed amount	(lower digits)	OFF	ON	ON	ON	Speed 7 (Pr.27)
478		(upper digits)	OFF	ON	ON	ON	
479	Eighth position feed amount	(lower digits)	ON	OFF	OFF	OFF	Speed 8 (Pr.232)
480		(upper digits)	ON	OFF	OFF	OFF	
481	Ninth position feed amount	(lower digits)	ON	OFF	OFF	ON	Speed 9 (Pr.233)
482		(upper digits)	ON	OFF	OFF	ON	
483	Tenth position feed amount	(lower digits)	ON	OFF	ON	OFF	Speed 10 (Pr.234)
484		(upper digits)	ON	OFF	ON	OFF	
485	Eleventh position feed amount	(lower digits)	ON	OFF	ON	ON	Speed 11 (Pr.235)
486		(upper digits)	ON	OFF	ON	ON	
487	Twelfth position feed amount	(lower digits)	ON	ON	OFF	OFF	Speed 12 (Pr.236)
488		(upper digits)	ON	ON	OFF	OFF	
489	Thirteenth position feed amount	(lower digits)	ON	ON	OFF	ON	Speed 13 (Pr.237)
490		(upper digits)	ON	ON	OFF	ON	

Parameter	Name	(lower digits) (upper digits)	Selection Method				Position Feed Speed
			RE X	RH	RM	RL	
491	Fourteenth position feed amount	(lower digits)	ON	ON	ON	OFF	Speed 14 (Pr.238)
492		(upper digits)	ON	ON	ON	OFF	
493	Fifteenth position feed amount	(lower digits)	ON	ON	ON	ON	Speed 15 (Pr.239)
494		(upper digits)	ON	ON	ON	ON	

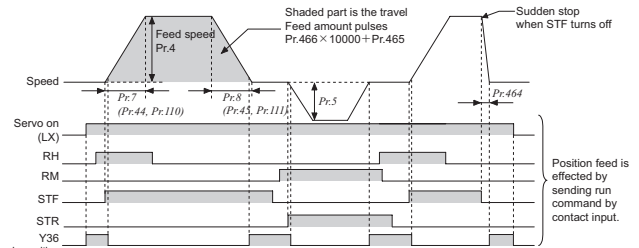

Pr. 419, 428 to 430
Position control by pulse train input of the inverter
 Vector

Pr.419 Position command source selection	Pr.428 Command pulse selection
Pr.429 Clear signal selection	Pr.430 Pulse monitor selection

Conditional position pulse train command can be input by pulse train input and sign signal (NP) from the JOG terminal.

- When 2 is set in Pr.419, conditional pulse train position command is selected.
- Select command pulse train using Pr.428.
- Turning on (short the terminal LX-SD) the servo on signal cancels the base circuit shut-off. When the terminal STF (forward rotation stroke end signal) or terminal STR (reverse rotation stroke end signal) and terminal SD are shorted at this time, the motor starts rotating in accordance with the command pulses. When the forward (reverse) rotation stroke end signal is opened, the motor does not run in the corresponding direction.

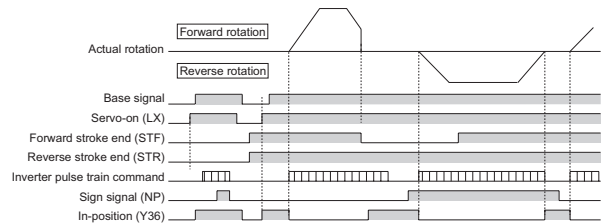

Pr. 420, 421, 424
Set the electronic gear for position control
 Vector

Pr.420 Command pulse scaling factor numerator	Pr.421 Command pulse scaling factor denominator
Pr.424 Position command acceleration/deceleration time constant	

Set the ratio of the machine side gear and the motor side gear.

Pr. Number	Setting Range	Description
420	0 to 32767	Set the electronic gear. Pr. 420 is a numerator and Pr. 421 is a denominator.
421		
424	0 to 50s	Used when rotation has become unsmooth at a large electronic gear ratio (about 10 times or more) and low speed.

Pr. 422, 423, 425
Gain adjustment of position control
 Vector

Pr.422 Position loop gain Pr.423 Position feed forward gain
 Pr.425 Position feed forward command filter

- Make adjustment of Pr.422 when any of such phenomena as unusual vibration, noise and overcurrent of the motor/machine occurs. Increasing the setting improves response for the position command and also improves servo rigidity at a stop, but oppositely makes an overshoot and vibration more liable to occur.
- Function of Pr.423 is designed to cancel a delay caused by the droop pulses of the deviation counter. Primary delay filter relative to the feed forward command can be input in Pr.425.

Pr. 426, 427
Positioning adjustment parameter
 Vector

Pr.426 In-position width Pr.427 Excessive level error

- When the number of droop pulses has fallen below the value set in Pr.426, the in-position signal (Y36) turns on.
- When droop pulses exceed the value set in Pr.427, position error large occurs and displays an error (E.OD) to stop the inverter.

- Pr. 450 ➔ Refer to the section about Pr.71.
- Pr. 451 ➔ Refer to the section about Pr.80.
- Pr. 453, 454 ➔ Refer to the section about Pr.80.
- Pr. 455 to 463 ➔ Refer to the section about Pr.82.

Pr. 495 to 497
Remote output function (REM signal)

Pr.495 Remote output selection Pr.496 Remote output data 1
 Pr.497 Remote output data 2

You can utilize the on/off of the inverter's output signals instead of the remote output terminal of the programmable logic controller.

Pr. Number	Setting Range	Description
420	0 (Initial Value)	Remote output data clear at powering off
	1	Remote output data retention even at powering off
	10	Remote output data clear at powering off
	11	Remote output data retention even at powering off
421	0 to 4095	Refer to the following diagram.
424	0 to 4095	

* The above parameters allow its setting to be changed during operation in any operation mode even if "0" (initial value) is set in Pr. 77 Parameter write selection.

<Remote output data>
 Pr. 496

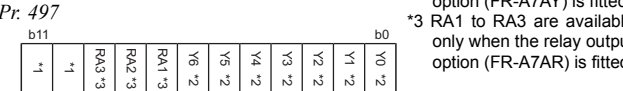
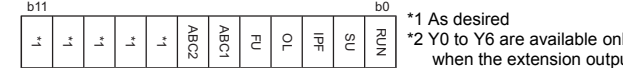

- *1 As desired
- *2 Y0 to Y6 are available only when the extension output option (FR-A7AY) is fitted
- *3 RA1 to RA3 are available only when the relay output option (FR-A7AR) is fitted

Pr. 503, 504
Maintenance of parts

Pr.503 Maintenance timer Pr.504 Maintenance timer alarm output set time

When the cumulative energization time of the inverter reaches the parameter set time, the maintenance timer output signal (Y95) is output. (MT) is displayed on the operation panel (FR-DU07).

This can be used as a guideline for the maintenance time of peripheral devices.

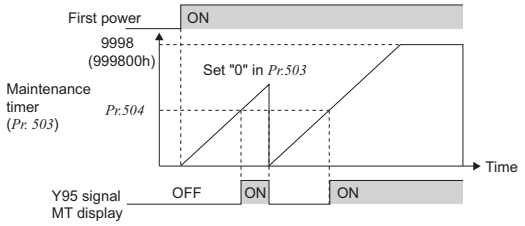

- The cumulative energization time of the inverter is stored into the EEPROM every hour and indicated in Pr.503 Maintenance timer in 100h increments. Pr.503 is clamped at 9998 (999800h).

Pr. 516 to 519 ➔ Refer to the section about Pr.29.

Pr. 547, 548, 551
Inverter setup using USB communication

Pr.547 USB communication station number Pr.548 USB communication check time interval
 Pr.551 PU mode operation command source selection

Inverter setup with setup software (FR Configurator) can be easily performed by USB communication. When performing parameter setting with setup software, set "3" in Pr.551 PU mode operation command source selection.

Pr. Number	Setting Range	Description
547	0 (initial value)	Set the station number of USB device (inverter) within the range "0 to 31".
	1 to 31	
548	0 to 999.8	Set the communication check time interval of USB communication. If data is not received within the time set in Pr.548, EUSB (E.USB) is displayed.
	9999 (initial value)	Communication time interval is not checked.

Pr. 549 ➔ Refer to the section about Pr.117.

Pr. 550, 551 ➔ Refer to the section about Pr.338.

- Features
- Peripheral Devices
- Standard Specifications
- Outline Dimension Drawings
- Terminal Connection Diagram Terminal Specification Explanation
- Operation Panel
- Parameter List
- Explanations of Parameters
- Protective Functions
- Options
- Instructions
- Motor
- Compatibility
- Warranty
- Inquiry

Pr. 555 to 557

Current average value monitor signal

Pr.555 Current average time Pr.556 Data output mask time
Pr.557 Current average value monitor signal output reference current

The average value of the output current during constant speed operation and the maintenance timer value are output as a pulse to the current average value monitor signal (Y93).

The pulse width output to the I/O module of the programmable controller or the like can be used as a guideline due to abrasion of machines and elongation of belt and for aged deterioration of devices to know the maintenance time.

The current average value monitor signal (Y93) is output as pulse for 20s as 1 cycle and repeatedly output during constant speed operation.

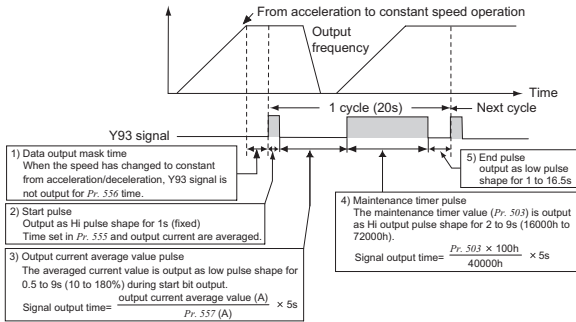

Pr. 563, 564 ➤ Refer to the section about Pr.52.

Pr. 569 ➤ Refer to the section about Pr.80.

Pr. 571 ➤ Refer to the section about Pr.13.

Pr. 575 to 577 ➤ Refer to the section about Pr.127.

Pr. 611 ➤ Refer to the section about Pr.57.

Pr. 665 ➤ Refer to the section about Pr.882.

Pr. 684 ➤ Refer to the section about Pr.82.

Pr. 800 ➤ Refer to the section about Pr.80.

Pr. 802 ➤ Refer to the section about Pr.10.

Pr. 803 ➤ Refer to the section about Pr.22.

Pr. 804 to 806

Torque command source selection

Sensorless Vector

Pr.804 Torque command source selection Pr.805 Torque command value (RAM)
Pr.806 Torque command value (RAM,EEPROM)

When you selected torque control, you can choose the torque command.

Pr. Number	Setting Range	Description
804	0 (initial value)	Torque command by terminal 1 analog input
	1	Torque command by parameter Pr.805 or Pr.806 setting (-400% to 400%)
	3	Torque command by CC-Link communication (FR-A7NC) Refer to the instruction manual of the option "FR-A7NC (option)" for details.
	4	Digital input from the option (FR-A7AX) Refer to the instruction manual of "FR-A7AX (option)" for details.
	5	Torque command by CC-Link communication (FR-A7NC) Refer to the instruction manual of the option "FR-A7NC (option)" for details.
	6	Torque command by CC-Link communication (FR-A7NC) Refer to the instruction manual of the option "FR-A7NC (option)" for details.
805	600 to 1400%	Digital setting of the torque command can be made by setting Pr.805 (RAM) or Pr.806 (RAM, EEPROM). (Setting from communication option, etc. can be made.)
806	600 to 1400%	In this case, set the speed limit value to an appropriate value to prevent overspeed.

- Torque command by terminal1 analog input
The torque command value for the analog input of the terminal 1 varies with C16, C17(Pr.919), C18, C19 (Pr.920) as shown below.

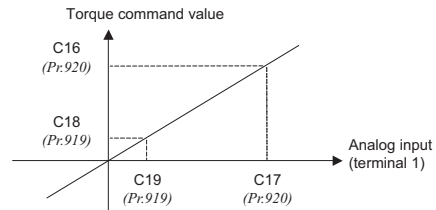

- Torque command by parameter
The relationship between the Pr.805 or Pr.806 setting and actual torque command value at this time is shown below. On the assumption that 1000% is 0%, the torque command is indicated by an offset from 1000%.

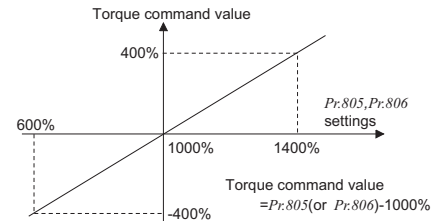

Pr 807 to 809
Speed limit during torque control
 Sensorless Vector

Pr.807 Speed limit selection Pr.808 Forward rotation speed limit
 Pr.809 Reverse rotation speed limit

When you selected torque control, set the speed limit value to prevent the load torque from becoming less than the torque command value, resulting in motor overspeed.

- Select the speed limit input method using Pr.807 .

Pr.807 Setting	Description
0 (initial value)	Use the speed command value during speed control as speed limit.
1	According to Pr.808 and Pr.809, set the speed limit in forward and reverse rotation directions individually. When the reverse rotation speed limit is 9999, the setting is the same as that of the torque limit in forward rotation direction.
2	The analog voltage of the terminal 1 input is used to make speed limit. For 0 to 10V input, set the forward rotation speed limit. (The reverse rotation speed limit is Pr.1 Maximum frequency .) For -10 to 0V input, set the reverse rotation speed limit. (The forward rotation speed limit is Pr.1 Maximum frequency .) The maximum frequency of both the forward and reverse rotations is Pr.1 Maximum frequency.

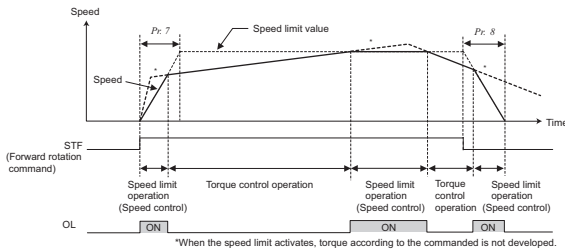

Pr 810, 812 to 817 ➔ Refer to the section about Pr.22.

Pr 818, 819
Easy gain tuning selection
 Sensorless Vector

Pr.818 Easy gain tuning response level setting Pr.819 Easy gain tuning selection

The ratio of the load inertia to the motor inertia (load inertia moment ratio) is estimated in real time from the torque command and speed during motor operation to automatically set gain (Pr.422, Pr.820, Pr.821, Pr.828) for each control from that ratio and response level setting (Pr.818).

Manually input the load inertia ratio during real sensorless vector control.

Time and effort of making gain adjustment can be reduced.

- Set the response level for finding each control gain from the load inertia ratio.

Pr.818 Setting Range	Description
1 to 15	1: Slow response ↓ 15: Fast response

- Valid/invalid of easy gain tuning can be selected.

Pr.819 Setting Range	Description
0	No tuning
1	With load estimation (only under vector control)
2	With tuning (manual load input)

When setting parameters, refer to the instruction manual (applied) and understand instructions.

Pr 820, 830
Speed loop proportional gain setting
 Sensorless Vector

Pr.820 Speed control P gain 1 Pr.830 Speed control P gain 2

- Set the proportional gain of the speed loop. Increasing the gain enhances the speed response level and decreases the speed fluctuation relative to disturbance, but a too large gain will produce vibration and/or sound.
- The setting range of Pr.820 Speed control P gain 1 and Pr.830 Speed control P gain 2 is 0 to 1000% and the initial value is 60%. For general adjustment, set them within the range 20 to 200%.

Pr 821, 831
Speed control integral time setting
 Sensorless Vector

Pr.821 Speed control integral time 1 Pr.831 Speed control integral time 2

- Set the integral compensation time of the speed loop. If speed fluctuation occurs relative to disturbance, decreasing the value shortens the recovery time, but a too small value will cause a speed overshoot. A large value improves stability but increases the recovery time (response time) and may cause an undershoot.

Pr 822 ➔ Refer to the section about Pr.74.

Pr 823, 833
Speed detection filter function
 Vector

Pr.823 Speed detection filter 1 Pr.833 Speed detection filter 2

- Set the time constant of the primary delay filter relative to the speed feedback signal. Since this function reduces the speed loop response, use it with the initial value. Set the time constant when speed ripples occur due to harmonic disturbance. Note that a too large value will run the motor unstably.

Pr 824, 834
Current loop proportional gain setting
 Sensorless Vector

Pr.824 Torque control P gain 1 Pr.834 Torque control P gain 2

- Set the proportional gain for torque control. Increasing the value improves response in response to a current command change and reduces current variation with disturbance. However, a too large gain will cause instability, generating harmonic torque pulsation.
- The setting range of Pr.824 Torque control P gain 1 and Pr.825 Torque control integral time 1 is 0 to 200% and the initial value is 100%. For general adjustment, set them within the range of 50 to 200%.

Pr 825, 835
Current control integral time setting
 Sensorless Vector

Pr.825 Torque control integral time 1 Pr.835 Torque control integral time 2

- Set the integral time of current control during torque control.
- A small value enhances the torque response level, but a too small value will cause current fluctuation.
- Decreasing the value shortens the time taken to return to the original torque if current variation with disturbance occurs.

Pr 826 ➔ Refer to the section about Pr.74.

Features
 Peripheral Devices
 Standard Specifications
 Outline Dimension Drawings
 Terminal Connection Diagram Terminal Specification Explanation
 Operation Panel
 Parameter List
 Explanations of Parameters
 Protective Functions
 Options
 Instructions
 Motor
 Compatibility
 Warranty
 Inquiry

Pr. 827, 837
Torque detection filter function
 Sensorless Vector

Pr.827 Torque detection filter 1 Pr.837 Torque detection filter 2

- Set the time constant of the primary delay filter relative to the torque feedback signal.
- Since the current loop response reduces, use it with the initial value.

Pr. 828, 877 to 881
Speed feed forward control, model adaptive speed control
 Sensorless Vector

Pr.828 Model speed control gain
 Pr.877 Speed feed forward control/model adaptive speed control selection
 Pr.878 Speed feed forward filter Pr.879 Speed feed forward torque limit
 Pr.880 Load inertia ratio Pr.881 Speed feed forward gain

- By making parameter setting, select the speed feed forward control or model adaptive speed control.
 The speed feed forward control enhances the response of the motor in response to a speed command change.
 The model adaptive speed control enables individual adjustment of speed response and motor disturbance torque response.

Pr.877 Setting	Description
0 (initial value)	Normal speed control is exercised.
1	Speed feed forward control is exercised.
2	Model adaptive speed control is enabled.

(1) Speed feed forward control

- Calculate required torque in response to the acceleration/deceleration command for the inertia ratio set in Pr.880 and generate torque immediately.
- When inertia ratio estimation has been made by easy gain tuning, the inertia ratio estimation result becomes the Pr.880 setting value from which speed feed forward is computed.
- When the speed feed forward gain is 100%, the calculation result of the speed feed forward is reflected as-is.
- If the speed command changes suddenly, large torque is generated due to the speed feed forward calculation. The maximum value of the speed feed forward is limited using Pr.879.
- Using Pr.878, the speed feed forward result can be dulled by the primary delay filter.

(2) Model adaptive speed control

- The motor's model speed is calculated to feed back the model side speed controller. This model speed is also used as the actual speed controller command.
- The inertia ratio in Pr. 880 is used for calculation of the torque current command value given by the model side speed controller.
 When inertia ratio estimation has been made by easy gain tuning, Pr. 880 is overwritten by the inertia ratio estimation result, and that value is used to calculate the torque current command value.
- The torque current command value of the model side speed controller is added to the output of the actual speed controller, and the result is used as the iq current control input.
- Pr.828 is used for model side speed control (P control), and the first gain in Pr. 820 is used for the actual speed controller. The model adaptive speed control is valid for the first motor only.
- When Pr.877 = 2, switching to the second motor handles the second motor as Pr.877 = 0.

- Pr. 830 ➤ Refer to the section about Pr.820.
- Pr. 831 ➤ Refer to the section about Pr.821.
- Pr. 832 ➤ Refer to the section about Pr. 74.
- Pr. 833 ➤ Refer to the section about Pr.823.
- Pr. 834 ➤ Refer to the section about Pr.824.

- Pr. 835 ➤ Refer to the section about Pr.825.
- Pr. 836 ➤ Refer to the section about Pr.74.
- Pr. 837 ➤ Refer to the section about Pr.827.

Pr. 840 to 848
Torque bias function
 Vector

Pr.840 Torque bias selection Pr.841 Torque bias 1
 Pr.842 Torque bias 2 Pr.843 Torque bias 3
 Pr.844 Torque bias filter Pr.845 Torque bias operation time
 Pr.846 Torque bias balance compensation Pr.847 Fall-time torque bias terminal 1 bias
 Pr.848 Fall-time torque bias terminal 1 gain

- This function accelerates the rise of the torque at a start. Adjust the torque at a motor start using the contact signals or analog signals.

Pr.840 Setting	Description
0	Set the contact signal (X42, X43) based-torque bias amount using Pr.841 to Pr.843.
1	Set the terminal 1-based torque bias amount as desired in C16 to C19. (forward rotation)
2	Set the terminal 1-based torque bias amount as desired in C16 to C19. (reverse rotation)
3	The terminal 1-based torque bias amount can be set automatically in C16 to C19, Pr.846 according to the load.
9999(initial value)	Without torque bias, rated torque 100%

- Pr.841 Torque bias 1, Pr.842 Torque bias 2, Pr.843 Torque bias 3
 On the assumption that the rated torque is 100%, the torque bias setting of 1000% is the center value of torque and the bias value is "0".
- Pr.844 Torque bias filter
 You can make a torque rise gentler. At this time, the torque rises according to the time constant of the primary delay filter.
- Pr.845 Torque bias operation time
 Set the time for output torque be maintained with the torque bias command value alone.
- Pr.846 Torque bias balance compensation
 Set the voltage of the torque bias analog input value input to the terminal 1 to compensate for the balance of the torque bias amount.
- Pr.847 Fall-time torque bias terminal 1 bias
 Set the torque bias amount at a fall time (when the motor runs in the reverse rotation direction).
- Pr.848 Fall-time torque bias terminal 1 gain
 Set the torque bias amount at a fall time.

- Pr. 849 ➤ Refer to the section about Pr.74.
- Pr. 850 ➤ Refer to the section about Pr.10.
- Pr. 853 ➤ Refer to the section about Pr.285.

Pr. 854
Excitation ratio
 Sensorless Vector

Pr.854 Excitation ratio

- Decrease the excitation ratio when you want to improve efficiency under light load. (motor magnetic noise decreases)
- Note that the rise of output torque becomes slow if excitation ratio is decreased.
 This function is appropriate for applications as machine tools which repeat rapid acceleration/deceleration up to high speed.

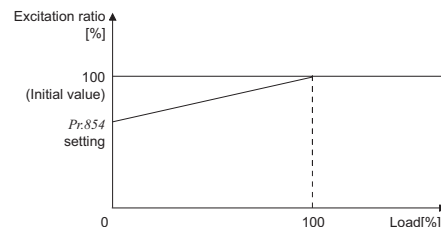

Pr. 858, 868

Function assignment of analog input terminal

Pr.858 Terminal 4 function assignment | Pr.868 Terminal 1 function assignment

Function assignment of terminal 1 and terminal 4 of analog input can be selected and changed by parameter.

- Terminal 1 function according to control

Pr.868 Setting	V/F Control Magnetic Flux Vector Control	Real Sensorless Vector Control /Vector Control		
		Speed control	Torque control	Position control*
0(initial value)	Frequency setting auxiliary	Speed setting auxiliary	Speed limit auxiliary	—
1	—	Magnetic flux command	Magnetic flux command	Magnetic flux command
2	—	Regenerative torque limit (Pr.810 = 1)	—	Regenerative torque limit (Pr.810 = 1)
3	—	—	Torque command (Pr.804 = 0)	—
4	Stall prevention operation level input(Pr.810 = 1)	Torque limit (Pr.810 = 1)	Torque command (Pr.804 = 0)	Torque limit (Pr.810 = 1)
5	—	—	Forward/reverse rotation speed limit	—
6	—	Torque bias input (Pr.840=1,2,3)	—	—
9999	—	—	—	—

* Position control is valid only during vector control

- Terminal 4 function according to control

Pr.858 Setting	V/F Control Magnetic Flux Vector Control	Real Sensorless Vector Control /vector Control		
		Speed control	Torque control	Position control*
0 (initial value)	Frequency command (AU signal-ON)	Speed command (AU signal-ON)	Speed limit (AU signal-ON)	—
1	—	Magnetic flux command	Magnetic flux command	Magnetic flux command
4	Stall prevention operation level input (Pr.810 = 1)	Torque limit (Pr.810 = 1)	—	Torque limit (Pr.810 = 1)
9999	—	—	—	—

* Position control is valid only during vector control

—:No function

Pr. 859, 860 ➤ Refer to the section about Pr.82.

Pr. 862, 863

Notch filter Sensorless Vector

Pr.862 Notch filter time constant | Pr.863 Notch filter depth

- You can reduce the response level of speed control in the resonance frequency band of the mechanical system to avoid mechanical resonance.
- Pr.862 Notch filter time constant

Setting	0	1	2	3	4	5	6	7	8	9
Frequency	Invalid	1000	500	333.3	250	200	166.7	142.9	125	111.1
Setting	10	11	12	13	14	15	16	17	18	19
Frequency	100	90.9	83.3	76.9	71.4	66.7	62.5	58.8	55.6	52.6
Setting	20	21	22	23	24	25	26	27	28	29
Frequency	50	47.6	45.5	43.5	41.7	40	38.5	37	35.7	34.5
Setting	30	31	32	33	34	35	36	37	38	39
Frequency	33.3	32.3	31.3	30.3	29.4	28.6	27.8	27.0	26.3	25.6
Setting	40	41	42	43	44	45	46	47	48	49
Frequency	25.0	24.4	23.8	23.3	22.7	22.2	21.7	21.3	20.8	20.4
Setting	50	51	52	53	54	55	56	57	58	59
Frequency	20.0	19.6	19.2	18.9	18.5	18.2	17.9	17.5	17.2	16.9

Setting	60
Frequency	16.7

- Pr.863 Notch filter depth

Setting	0	1	2	3
Depth	Deep	←	→	Shallow
Gain	-40dB	-14dB	-8dB	-4dB

When setting parameters, refer to the instruction manual (applied) and understand instructions.

Pr. 864

Torque detection Magnetic flux Sensorless Vector

Pr.864 Torque detection

- This function outputs a signal if the motor torque rises to or above the Pr.864 setting.
- The signal is used as operation and open signal for an electromagnetic brake.

The signal turns on when the output torque rises to or above the detection torque value set in Pr.864. It turns off when the torque falls below the detection torque value.

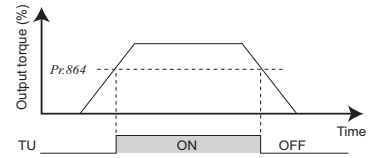

Pr. 865 ➤ Refer to the section about Pr.41.

Pr. 866 ➤ Refer to the section about Pr.55.

Pr. 867 ➤ Refer to the section about Pr.52.

Pr. 868 ➤ Refer to the section about Pr.858.

Pr. 872 ➤ Refer to the section about Pr.251.

Pr. 873

Speed limit during speed control Vector

Pr.873 Speed limit

- Frequency is limited at the set frequency + Pr.873 during vector control.

Pr. 874 ➤ Refer to the section about Pr.22.

Pr. 875

Fault definition

Pr.875 Fault definition

When the electronic thermal function is activated, the motor decelerates to a stop and the base circuit is shut off.

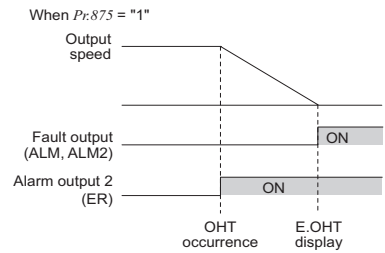

Pr.875 Setting	Operation	Description
0 (initial value)	Normal operation	At occurrence of any alarm, the base circuit is shut off immediately. At this time, the alarm output also turns on.
1	Fault definition	At occurrence of external thermal operation (OHT), electronic thermal relay function (THM) or PTC thermistor function (PTC) alarm, the motor is decelerated to a stop and the base circuit is shut off. At occurrence of an alarm other than OHT, THM and PTC, the base circuit is shut off immediately. Same operation as when "0" is set is performed under position control.

Pr. 877 to 881 ➤ Refer to the section about Pr.828.

- Features
- Peripheral Devices
- Standard Specifications
- Outline Dimension Drawings
- Terminal Connection Diagram Terminal Specification Explanation
- Operation Panel
- Parameter List
- Explanations of Parameters
- Protective Functions
- Options
- Instructions
- Motor
- Compatibility
- Warranty
- Inquiry

Pr. 882 to 886, 665
Regeneration avoidance function

Pr.882 Regeneration avoidance operation selection | Pr.883 Regeneration avoidance operation level
 Pr.884 Regeneration avoidance at deceleration detection sensitivity
 Pr.885 Regeneration avoidance compensation frequency limit value
 Pr.886 Regeneration avoidance voltage gain | Pr.665 Regeneration avoidance frequency gain

This function detects a regeneration status and increases the frequency to avoid the regeneration status.

- Possible to avoid regeneration by automatically increasing the frequency and continue operation if the fan happens to rotate faster than the set speed due to the effect of another fan in the same duct.

Pr. Number	Setting Range	Description
882	0 (initial value)	Regeneration avoidance function invalid
	1	Regeneration avoidance function is always valid
	2	Regeneration avoidance function is valid only during a constant speed operation
883	300 to 800V	Set the bus voltage level at which regeneration avoidance operates. When the bus voltage level is set to low, overvoltage error will be less apt to occur. However, the actual deceleration time increases. The set value must be higher than the "power supply voltage $\times \sqrt{2}$ ".
884	0 (initial value)	Regeneration avoidance by bus voltage change ratio is invalid
	1 to 5	Set sensitivity to detect the bus voltage change ratio. Setting 1 \rightarrow 5 Detection sensitivity low \rightarrow high
885	0 to 10Hz	Set the limit value of frequency which rises at activation of regeneration avoidance function.
	9999	Frequency limit invalid
886	0 to 200%	Adjust responsiveness at activation of regeneration avoidance. A larger setting will improve responsiveness to the bus voltage change. However, the output frequency could become unstable. When the load inertia of the motor is large, decrease the Pr. 886 setting. When vibration is not suppressed by decreasing the Pr.886 setting, set a smaller value in Pr.665.
665	0 to 200%	

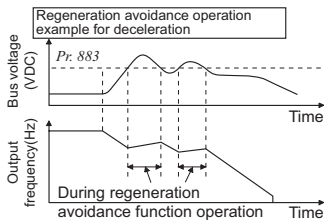

Pr. 888, 889
Free parameter

Pr.888 Free parameter 1 | Pr.889 Free parameter 2

Parameters you can use for your own purposes. You can input any number within the setting range 0 to 9999. For example, the number can be used:

- As a unit number when multiple units are used.
- As a pattern number for each operation application when multiple units are used.
- As the year and month of introduction or inspection.

Pr. 891 \rightarrow Refer to the section about Pr.52.

Pr. 892 to 899
Energy saving monitor

Pr.892 Load factor
 Pr.893 Energy saving monitor reference (motor capacity)
 Pr.894 Control selection during commercial power-supply operation
 Pr.895 Power saving rate reference value
 Pr.896 Power unit cost | Pr.897 Power saving monitor average time
 Pr.898 Power saving cumulative monitor clear | Pr.899 Operation time rate (estimated value)

From the power consumption estimated value during commercial power supply operation, the energy saving effect by use of the inverter can be monitored/output.

- The following provides the items that can be monitored by the power saving monitor (Pr.52, Pr.54, Pr.158 = "50")
 (Only power saving and power saving average value can be output to Pr.54 (terminal FM) and Pr.158 (terminal AM))

Energy Saving Monitor Item	Description and Formula	Increments
Power savings	Difference between the estimated value of power necessary for commercial power supply operation and the input power calculated by the inverter Power during commercial power supply operation - input power monitor	0.01kW /0.1kW*
Power saving rate	Ratio of power saving on the assumption that power during commercial power supply operation is 100% Power savings $\frac{\text{Power during commercial power supply}}{\text{Power during commercial power supply}} \times 100$	0.1%
	Ratio of power saving on the assumption that Pr.893 is 100% Power savings $\frac{\text{Pr.893}}{\text{Pr.893}} \times 100$	
Power savings average value	Average value of power saving amount per hour during predetermined time (Pr.897) $\frac{\sum (\text{Power saving} \times \Delta t)}{\text{Pr.897}}$	0.01kWh /0.1kWh*
Power saving rate average value	Ratio of power saving average value on the assumption that the value during commercial power supply operation is 100% $\frac{\sum (\text{Power saving rate} \times \Delta t)}{\text{Pr.897}} \times 100$	0.1%
	Ratio of power saving average value on the assumption that Pr.893 is 100% Energy saving average $\frac{\text{Pr.893}}{\text{Pr.893}} \times 100$	
Power saving charge average value	Power saving average value represented in terms of charge Power saving average value \times Pr.896	0.01/0.1*

- The following shows the items which can be monitored by the cumulative saving power monitor (Pr.52 = "51").
 (The cumulative power monitor data digit can be shifted to the right by the number set in Pr. 891 Cumulative power monitor digit shifted times.)

Energy Saving Monitor Item	Description and Formula	Increments
Power saving amount	Power saving is added up per hour $\sum (\text{Power saving} \times \Delta t)$	0.01kWh/ 0.1kWh*
Power saving amount charge	Power saving average value represented in terms of charge Power saving amount \times Pr.896	0.01/0.1*
Annual power saving amount	Estimated value of annual power saving amount $\frac{\text{Power saving amount}}{\text{Operation time during}} \times 24 \times 365 \times \frac{\text{Pr.899}}{100}$	0.01kWh/ 0.1kWh*
Annual power saving amount charge	Annual power saving amount represented in terms of charge Annual power saving amount \times Pr.896	0.01/0.1*

* The increments differ according to the inverter capacity. (55K or less/75K or more)

Pr C0(900), C1(901)
Adjustment of terminal FM and AM output (calibration)

C0 (Pr.900) FM terminal calibration C1 (Pr.901) AM terminal calibration

By using the operation panel or parameter unit, you can calibrate terminal FM and terminal AM to full scale deflection.

(1) FM terminal calibration (C0 (Pr.900))

- The terminal FM is preset to output pulses. By setting the calibration parameter C0 (Pr.900), the meter connected to the inverter can be calibrated by parameter setting without use of a calibration resistor.
- Using the pulse train output of the terminal FM, a digital display can be provided by a digital counter. The monitor value is 1440 pulses/s output at the full-scale value of Pr.54 FM terminal function selection.

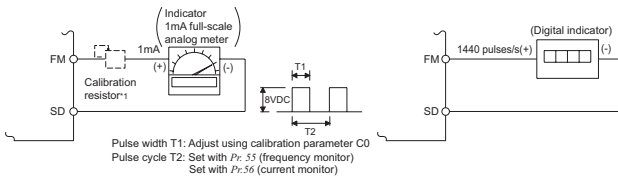

*1 Not needed when the operation panel (FR-DU07) or parameter unit (FR-PU04/FR-PU07) is used for calibration. Used when calibration must be made near the frequency meter for such a reason as a remote frequency meter. However, the frequency meter needle may not deflect to full-scale if the calibration resistor is connected. In this case, use this resistor and operation panel or parameter unit together.

- When the FM terminal is set to the open collector output using Pr.291 Pulse train I/O selection, pulse train output can not be calibrated using Pr.900.

(2)AM terminal calibration (C1 (Pr.901))

- The AM terminal is factory-set to output 10VDC in the full-scale state of each monitor item. By setting the AM terminal calibration C1(Pr.901), the ratio (gain) of the output voltage can be adjusted to the meter scale. Note that the maximum output voltage is 10VDC.

Pr C2(902) to C7(905), C12(917) to C19(920), C38(932) to C41(933)

➤ Refer to the section about Pr.125.

Pr 989, CL, ALLC, Er.CL, PCPY
Parameter clear, parameter copy

Pr.989 Parameter copy alarm release ALLC All parameter clear
 Pr.CL Parameter clear PCPY Parameter copy
 Er.CL Fault history clear

- Set "1" in Pr.CL Parameter clear to initialize all parameters. (Calibration parameters are not cleared.)*
- Set "1" in ALLC All parameter clear to initialize all parameters.*
- Set "1" in Er.CL Fault history clear to clear alarm history.
- Parameter settings can be copied to multiple inverters by using PCPY.

When parameters are copied to the 75K or more inverter from the 55K or less inverter or vice versa, an alarm CP appears on the operation panel.

For the parameters whose setting range differ, set Pr.989 as below after reset.

	55K or less	75K or more
Pr.989 setting	10	100

PCPY Setting	Description
0	Cancel
1	Copy the source parameters to the operation panel.
2	Write the parameters copied to the operation panel to the destination inverter.
3	Verify parameters in the inverter and operation panel.

* Parameters are not cleared when "1" is set in Pr.77 Parameter write selection.

Pr 990
Buzzer control of the operation panel

Pr.990 PU buzzer control

You can make the buzzer "beep" when you press key of the operation panel (FR-DU07) and parameter unit (FR-PU04/FR-PU07)

Pr.990 Setting	Description
0	Without buzzer
1 (initial value)	With buzzer

Pr 991
PU contrast adjustment

Pr.991 PU contrast adjustment

Contrast adjustment of the LCD of the parameter unit (FR-PU04/FR-PU07) can be performed.

Decreasing the setting value makes contrast light.

Pr.991 Setting	Description
0 to 63	0: Light ↓ 63: Dark

Protective Functions

When an alarm occurs in the inverter, the protective function is activated bringing the inverter to an alarm stop and the PU display automatically changes to any of the following error (alarm) indications.

	Function Name	Description	Display
Error Message *2	Operation panel lock	Appears when operation was tried during operation panel lock.	HOLD
	Parameter write error	Appears when an error occurred during parameter writing.	Er1 to Er4
	Copy operation error	Appears when an error occurred during parameter copying.	rEr1 to rEr4
	Error	Appears when the RES signal is on or the PU and inverter can not make normal communication.	Err.
Warnings *3	Stall prevention (overcurrent)	Appears during overcurrent stall prevention.	OL
	Stall prevention (overvoltage)	Appears during overvoltage stall prevention. Appears while the regeneration avoidance function is activated.	oL
	Regenerative brake prealarm *8	Appears if the regenerative brake duty reaches or exceeds 85% of the Pr.70 Special regenerative brake duty value. If the regenerative brake duty reaches 100%, a regenerative overvoltage (E.OV_) occurs.	rb
	Electronic thermal relay function prealarm	Appears when the electronic thermal O/L relay has reached 85% of the specified value.	rH
	PU stop	Appears when  on the operation panel was pressed during external operation.	PS
	Maintenance signal output *8	Appears when the cumulative energization time has exceeded the maintenance output timer set value.	nr
	Parameter copy	Appears when parameters are copied between models with capacities of 55K or less and 75K or more.	CP
	Speed limit display (output during speed limit)	Display if the speed limit level is exceeded during torque control.	SL
Minor failure *4	Fan fault	Appears when the cooling fan remains stopped when operation is required or when the speed has decreased.	Fn
Major failures *5	Overcurrent shutoff during acceleration	Appears when an overcurrent occurred during acceleration.	EOC1
	Overcurrent shutoff during constant speed	Appears when an overcurrent occurred during constant speed operation.	EOC2
	Overcurrent shut-off during deceleration or stop	Appears when an overcurrent occurred during deceleration and at a stop.	EOC3
	Regenerative overvoltage shut-off during acceleration	Appears when an overvoltage occurred during acceleration.	EOv1
	Regenerative overvoltage shut-off during constant speed	Appears when an overvoltage occurred during constant speed operation.	EOv2
	Regenerative overvoltage shut-off during deceleration or stop	Appears when an overvoltage occurred during deceleration and at a stop.	EOv3
	Inverter overload shut-off (Electronic thermal relay function) *1	Appears when the electronic thermal relay function for inverter element protection was activated.	EΓHF
	Motor overload shut-off (Electronic thermal relay function) *1	Appears when the electronic thermal relay function for motor protection was activated.	EΓHN
	Fin overheat	Appears when the heatsink overheated.	EFl n
	Instantaneous power failure	Appears when an instantaneous power failure occurred at an input power supply.	EIPF
	Undervoltage	Appears when the main circuit DC voltage became low.	EUvF
	Input phase loss *8	Appears if one of the three phases on the inverter input side opened.	EILF
	Stall prevention	Appears when the output frequency drops to 0.5Hz as a result of deceleration due to the excess motor load.	EOLr
	Brake transistor alarm detection	This function stops the inverter output if an alarm occurs in the brake circuit, e.g. damaged brake transistors. In this case, the inverter must be powered off immediately.	E.bE
	Output side earth (ground) fault overcurrent	Appears when an earth (ground) fault occurred on the Inverter's output side.	E.GF
	Output phase loss	Appears if one of the three phases on the inverter output side opened.	E.LF
	External thermal relay operation *6 *8	Appears when the external thermal relay connected to the terminal OH is activated.	EOHF
	PTC thermistor operation *8	Appears when the motor overheat status is detected for 10s or more by the external PTC thermistor input connected to the terminal AU.	EPTC

Function Name	Description	Display
Option alarm	Appears when torque command by the plug-in option is selected using <i>Pr. 804</i> when no plug-in option is mounted or an AC power supply is connected to the R/L1, S/L2, T/L3 when the high power factor converter and power regeneration common converter connection setting (<i>Pr.30 =2</i>) is selected.	<i>EOPr</i>
Communication option alarm	Appears when a communication line error occurs in the communication option.	<i>EOP3</i>
Option alarm	Appears if a contact fault or the like of the connector between the inverter and communication option occurs or if a communication option is fitted to the connector 1 or 2. (1 to 3 indicate connector numbers for connection of the plug-in option .	<i>E. 1</i> to <i>E. 3</i>
Parameter storage device alarm	Appears when operation of the element where parameters stored became abnormal. (control board)	<i>E. PE</i>
PU disconnection	Appears when a communication error between the PU and inverter occurred, the communication interval exceeded the permissible time during the RS-485 communication with the PU connector, or communication errors exceeded the number of retries during the RS-485 communication.	<i>EPUE</i>
Retry count excess *8	Appears when the operation was not restarted within the set number of retries.	<i>E.rEr</i>
Parameter storage device alarm	Appears when operation of the element where parameters stored became abnormal. (main circuit board)	<i>EPE2</i>
CPU error	Appears during the CPU and peripheral circuit errors occurred.	<i>E. 61</i> <i>E. 71</i> <i>ECPU</i>
Operation panel power supply short circuit RS-485 terminals power supply short circuit	Appears when the RS-485 terminal power supply or operation panel power supply was shorted.	<i>EEFE</i>
24VDC power output short circuit	Appears when terminals PC-SD were shorted.	<i>EP24</i>
Output current detection value excess *8	Appears when output current exceeded the output current detection level set by the parameter.	<i>EEOd</i>
Inrush resistor overheat	Appears when the resistor of the inrush current limit circuit overheated.	<i>E1OH</i>
Communication alarm (inverter)	Appears when a communication error occurred during the RS-485 communication with the RS-485 terminals.	<i>ESEr</i>
Analog input error	Appears when 30mA or more is input or a voltage (7.5V or more) is input with the terminal 2/4 set to current input.	<i>ERIE</i>
Overspeed occurrence *7 *8	Indicates that the motor speed has exceeded the overspeed setting level (<i>Pr.374</i>).	<i>E. OS</i>
Speed deviation excess detection *7 *8	Stops the inverter output if the motor speed is increased or decreased under the influence of the load etc. during vector control and cannot be controlled in accordance with the speed command value.	<i>EOSd</i>
Open cable detection *7 *8	Stops the inverter output if the encoder signal is shut off.	<i>EECr</i>
Position error large *7 *8	Indicates that the difference between the position command and position feedback exceeded the reference.	<i>E. Od</i>
Brake sequence error *8	The inverter output is stopped when a sequence error occurs during use of the brake sequence function (<i>Pr.278 to Pr.285</i>).	<i>ENb 1</i> to <i>ENb7</i>
Encoder phase error *7 *8	When the rotation command of the inverter differs from the actual motor rotation direction detected from the encoder, the inverter output is stopped. (detected only during tuning is performed in the "rotation mode" of offline auto tuning)	<i>EEP</i>
Internal circuit error	Appears when an internal circuit error occurred.	<i>E. 13</i>
USB error	Appears when USB communication error occurred.	<i>EUSB</i>
Opposite rotation deceleration alarm *8	The speed may not decelerate during low speed operation if the rotation direction of the speed command and the estimated speed differ when the rotation is changing from forward to reverse or from reverse to forward under real sensorless vector control. At this time, the inverter output is stopped if the rotation direction will not change, causing overload.	<i>E. 11</i>

- *1. Resetting the inverter initializes the internal thermal integrated data of the electronic thermal relay function.
- *2. The error message shows an operational error. The inverter output is not shut off.
- *3. Warnings are messages given before major failures occur. The inverter output is not shut off.
- *4. Minor failure warns the operator of failures with output signals. The inverter output is not shut off.
- *5. When major failures occur, the protective functions are activated to shut off the inverter output and output the alarms.
- *6. The external thermal operates only when the OH signal is set in *Pr.178 to Pr.189* (input terminal function selection).
- *7. Appears when the FR-A7AP (option) is fitted.
- *8. This protective function does not function in the initial status.

- Features
- Peripheral Devices
- Standard Specifications
- Outline Dimension Drawings
- Terminal Connection Diagram Terminal Specification Explanation
- Operation Panel
- Parameter List
- Explanations of Parameters
- Protective Functions
- Options
- Instructions
- Motor
- Compatibility
- Warranty
- Inquiry

Option and Peripheral Devices

Option List

By fitting the following options to the inverter, the inverter is provided with more functions.

Three plug-in options can be fitted at a time. (more than two same options and communication options can not be fitted)

Name		Type	Applications, Specifications, etc.	Applicable Inverter	
Plug-in Type	Vector control	FR-A7AP	Vector control with encoder can be performed.	Shared among all models	
	Orientation/encoder		The main spindle can be stopped at a fixed position (orientation) in combination with a pulse encoder. The motor speed is sent back and the speed is maintained constant.		
	16-bit digital input	FR-A7AX	<ul style="list-style-type: none"> This input interface sets the high frequency accuracy of the inverter using an external BCD or binary digital signal. BCD code 3 digits (maximum 999) BCD code 4 digits (maximum 9999) Binary 12 bits (maximum FFFH) Binary 16 bits (maximum FFFFH) 		
	Digital output Extension analog output	FR-A7AY	<ul style="list-style-type: none"> Output signals provided with the inverter as standard are selected to output from the open collector. This option adds 2 different signals that can be monitored at the terminals AM0 and AM1, such as the output frequency, output voltage and output current. 20mADC or 10VDC meter can be connected. 		
	Relay output		FR-A7AR		Output any three output signals available with the inverter as standard from the relay contact terminals.
	Communication	CC-Link communication	FR-A7NC		<ul style="list-style-type: none"> This option allows the inverter to be operated or monitored or the parameter setting to be changed from a computer or programmable controller. *For the FR-A7NC (CC-Link), the above operations can be done from the programmable controller only.
		LONWORKS communication	FR-A7NL		
DeviceNet communication		FR-A7ND			
PROFIBUS-DP communication		FR-A7NP			
Stand-alone Shared	Parameter unit (8 languages)	FR-PU07 FR-PU04	Interactive parameter unit with LCD display	Shared among all models	
	Parameter unit connection cable	FR-CB20□	Cable for connection of operation panel or parameter unit □ indicates a cable length. (1m, 3m, 5m)		
	Operation panel connection connector	FR-ADP	Connector to connect the operation panel (FR-DU07) and connection cable		
	Cable for encoder Mitsubishi vector control dedicated motor (SF-V5RU)	FR-V7CBL□□	Connection cable for the inverter and encoder for Mitsubishi vector control dedicated motor (SF-V5RU). □ indicates a cable length. (5m, 15m, 30m)		
	Heatsink protrusion attachment	FR-A7CN01 to 11	The inverter heatsink section can be protruded outside of the rear of the enclosure. For a panel cut dimension drawing, refer to <i>page 19</i> .	FR-A720-1.5K to 90K FR-A740-0.4K to 132K According to capacities	
	Intercompatibility attachment	FR-AAT24	Attachment for replacing with the A700 series using the installation holes of the FR-A500 series.	FR-A740-11K, 15K	
		FR-A5AT	Attachment for replacing with the FR-A700 series using the installation holes of the FR-A100<Excellent> and FR-A200<Excellent>	According to capacities	
	AC reactor	FR-HAL	For harmonic suppression measures and improvement of inverter input power factor (total power factor approx. 88%)	According to capacities	
	DC reactor	FR-HEL	For harmonic suppression measures and improvement of inverter input power factor (total power factor approx. 93%)	Compatible with the 55K or less	
	Line noise filter	FR-BSF01 FR-BLF	For line noise reduction	Shared among all models	
	High-duty brake resistor	FR-ABR	For improvement of braking capability of the built-in brake of the inverter	Compatible with the 22K or less	
	BU type brake unit	BU	For increasing the braking capability of the inverter (for high-inertia load or negative load)	Compatible with the 55K or less	
Brake unit Resistor unit	FR-BU FR-BR	For increasing the braking capability of the inverter (for high-inertia load or negative load) Brake unit and resistor unit are used in combination	Compatible with the 55K or less		
	MT-BU5 MT-BR5		Compatible with the 75K or more		

	Name		Type	Applications, Specifications, etc.	Applicable Inverter
Stand-alone Shared	Power regeneration common converter Stand-alone reactor dedicated for the FR-CV		FR-CV FR-CVL	Unit which can return motor-generated braking energy back to the power supply in common converter system	Compatible with the 55K or less
	Power regeneration converter		MT-RC	Energy saving type high performance brake unit which can regenerate the braking energy generated by the motor to the power supply.	Compatible with the 75K or more
	High power factor converter		FR-HC	The high power factor converter switches the converter section on/off to reshape an input current waveform into a sine wave, greatly suppressing harmonics. (Used in combination with the standard accessory.)	Compatible with the 55K or less
			MT-HC		Compatible with the 75K or more
	Surge voltage suppression filter		FR-ASF	Filter for suppressing surge voltage on motor	Compatible with the 400V class 55K or less
Sine wave filter	Reactor	MT-BSL (-HC)	Reduce the motor noise during inverter driving Use in combination with a reactor and a capacitor	Compatible with the 75K or more	
	Capacitor	MT-BSC			
FR Series Manual Controller/Speed Controller	Manual controller		FR-AX	For independent operation. With frequency meter, frequency potentiometer and start switch.	Shared among all models
	DC tach. follower		FR-AL	For synchronous operation (1VA) by external signal (0 to 5V, 0 to 10V DC) *	
	Three speed selector		FR-AT	For three speed switching, among high, middle and low speed operation (1.5VA) *	
	Motorized speed setter		FR-FK	For remote operation. Allows operation to be controlled from several places (5VA) *	
	Ratio setter		FR-FH	For ratio operation. Allows ratios to be set to five inverters. (3VA)*	
	Speed detector		FR-FP	For tracking operation by a pilot generator (PG) signal (3VA) *	
	Master controller		FR-FG	Master controller (5VA) for parallel operation of multiple (maximum 35) inverters. *	
	Soft starter		FR-FC	For soft start and stop. Enables acceleration/ deceleration in parallel operation (3VA) *	
	Deviation detector		FR-FD	For continuous speed control operation. Used in combination with a deviation sensor or synchro (5VA) *	
	Pre-amplifier		FR-FA	Used as an A/V converter or arithmetic amplifier (3VA) *	
Others	Pilot generator		QVAH-10	For tracking operation. 70V/35VAC 500Hz (at 2500r/min)	
	Deviation sensor		YVGC-500W-NS	For continuous speed control operation (mechanical deviation detection) Output 90VAC/90°	
	Frequency setting potentiometer		WA2W 1kΩ	For frequency setting. Wire-wound 2W 1kΩ type B characteristic	
	Analog frequency meter (64mm × 60mm)		YM206NRI 1mA	Dedicated frequency meter (graduated to 120Hz). Moving-coil type DC ammeter	
	Calibration resistor		RV24YN 10kΩ	For frequency meter calibration. Carbon film type B characteristic	
	Inverter setup software (FR Configurator)		FR-SW3-SETUP-WE	Supports an inverter startup to maintenance.	

* Rated power consumption. The power supply specifications of the FR series manual controllers and speed controllers are 200VAC 50Hz, 220V/220VAC 60Hz, and 115VAC 60Hz.

- Features
- Peripheral Devices
- Standard Specifications
- Outline Dimension Drawings
- Terminal Connection Diagram Terminal Specification Explanation
- Operation Panel
- Parameter List
- Explanations of Parameters
- Protective Functions
- Options
- Instructions
- Motor
- Compatibility
- Warranty
- Inquiry

Stand-alone Option

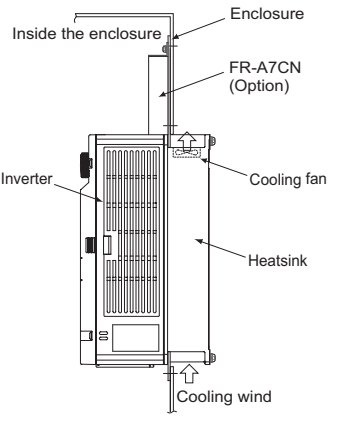
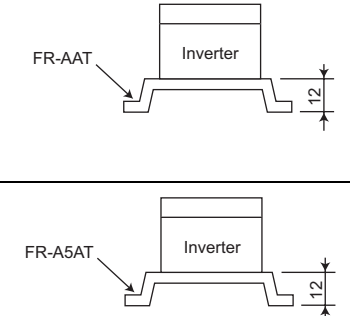
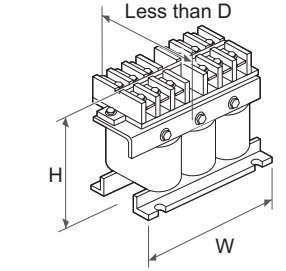
Name (type)	Specifications, Structure, etc.																																																																																																																																																																																																																																					
Heatsink protrusion attachment FR-A7CN□□	<ul style="list-style-type: none"> With this attachment the heatsink which is the exothermic section of the inverter can be placed on the rear of the enclosure. Since the heat generated in the inverter can be radiated to the rear of the enclosure, the enclosure can be downsized. The use of this attachment requires more installation area. For installation, refer to the drawing after attachment installation (page 19). For a panel cutting drawing, refer to page 19. <table border="1" data-bbox="359 414 997 728"> <thead> <tr> <th rowspan="2">Type</th> <th colspan="2">Applied Inverter</th> </tr> <tr> <th>200V Class</th> <th>400V Class</th> </tr> </thead> <tbody> <tr> <td>FR-A7CN01</td> <td>FR-A720-1.5K to 3.7K</td> <td>FR-A740-0.4K to 3.7K</td> </tr> <tr> <td>FR-A7CN02</td> <td>FR-A720-5.5K, 7.5K</td> <td>FR-A740-5.5K, 7.5K</td> </tr> <tr> <td>FR-A7CN03</td> <td>FR-A720-11K</td> <td>FR-A740-11K, 15K</td> </tr> <tr> <td>FR-A7CN04</td> <td>FR-A720-15K to 22K</td> <td>FR-A740-18.5K, 22K</td> </tr> <tr> <td>FR-A7CN05</td> <td>FR-A720-30K</td> <td>—</td> </tr> <tr> <td>FR-A7CN06</td> <td>—</td> <td>FR-A740-30K</td> </tr> <tr> <td>FR-A7CN07</td> <td>FR-A720-37K, 45K</td> <td>FR-A740-37K to 55K</td> </tr> <tr> <td>FR-A7CN08</td> <td>—</td> <td>FR-A740-75K</td> </tr> <tr> <td>FR-A7CN09</td> <td>—</td> <td>FR-A740-90K</td> </tr> <tr> <td>FR-A7CN10</td> <td>FR-A720-75K, 90K</td> <td>FR-A740-110K, 132K</td> </tr> <tr> <td>FR-A7CN11</td> <td>FR-A720-55K</td> <td>—</td> </tr> </tbody> </table>	Type	Applied Inverter		200V Class	400V Class	FR-A7CN01	FR-A720-1.5K to 3.7K	FR-A740-0.4K to 3.7K	FR-A7CN02	FR-A720-5.5K, 7.5K	FR-A740-5.5K, 7.5K	FR-A7CN03	FR-A720-11K	FR-A740-11K, 15K	FR-A7CN04	FR-A720-15K to 22K	FR-A740-18.5K, 22K	FR-A7CN05	FR-A720-30K	—	FR-A7CN06	—	FR-A740-30K	FR-A7CN07	FR-A720-37K, 45K	FR-A740-37K to 55K	FR-A7CN08	—	FR-A740-75K	FR-A7CN09	—	FR-A740-90K	FR-A7CN10	FR-A720-75K, 90K	FR-A740-110K, 132K	FR-A7CN11	FR-A720-55K	—																																																																																																																																																																																															
Type	Applied Inverter																																																																																																																																																																																																																																					
	200V Class	400V Class																																																																																																																																																																																																																																				
FR-A7CN01	FR-A720-1.5K to 3.7K	FR-A740-0.4K to 3.7K																																																																																																																																																																																																																																				
FR-A7CN02	FR-A720-5.5K, 7.5K	FR-A740-5.5K, 7.5K																																																																																																																																																																																																																																				
FR-A7CN03	FR-A720-11K	FR-A740-11K, 15K																																																																																																																																																																																																																																				
FR-A7CN04	FR-A720-15K to 22K	FR-A740-18.5K, 22K																																																																																																																																																																																																																																				
FR-A7CN05	FR-A720-30K	—																																																																																																																																																																																																																																				
FR-A7CN06	—	FR-A740-30K																																																																																																																																																																																																																																				
FR-A7CN07	FR-A720-37K, 45K	FR-A740-37K to 55K																																																																																																																																																																																																																																				
FR-A7CN08	—	FR-A740-75K																																																																																																																																																																																																																																				
FR-A7CN09	—	FR-A740-90K																																																																																																																																																																																																																																				
FR-A7CN10	FR-A720-75K, 90K	FR-A740-110K, 132K																																																																																																																																																																																																																																				
FR-A7CN11	FR-A720-55K	—																																																																																																																																																																																																																																				
Intercompatibility attachment FR-AAT24 FR-A5AT□□	<ul style="list-style-type: none"> FR-A500 series intercompatibility attachment The FR-A700 series inverter can be installed using installation holes of the conventional FR-A500 series with this attachment. This attachment is useful for replacing the conventional model with the FR-A700 series. *The depth increases after installation of the inverter when the attachment is used. <table border="1" data-bbox="359 884 726 940"> <thead> <tr> <th>Type</th> <th>Applicable Inverter</th> </tr> </thead> <tbody> <tr> <td>FR-AAT24</td> <td>FR-A740-11K, 15K</td> </tr> </tbody> </table> <ul style="list-style-type: none"> FR-A200E/A100E series intercompatibility attachment The FR-A700 series inverter can be installed using installation holes of the conventional FR-A200E/A100E series with this attachment. This attachment is useful for replacing the conventional model with the FR-A700 series. *The depth increases after installation of the inverter when the attachment is used. <table border="1" data-bbox="359 1086 1428 1310"> <thead> <tr> <th rowspan="2">Type</th> <th colspan="3">Mountable Models</th> <th colspan="4">Compatible Former Models</th> </tr> <tr> <th>A720</th> <th>A740</th> <th>A220E</th> <th>A240E</th> <th>A120E</th> <th>A140E</th> </tr> </thead> <tbody> <tr> <td>A5AT01</td> <td>0.4K, 0.75K</td> <td>—</td> <td>0.4K, 0.75K</td> <td>—</td> <td>0.75K</td> <td>—</td> </tr> <tr> <td>A5AT02</td> <td>0.4K, 0.75K, 1.5K, 2.2K, 3.7K</td> <td>0.4K, 0.75K, 1.5K, 2.2K, 3.7K</td> <td>1.5K, 2.2K, 3.7K</td> <td>0.4K, 0.75K, 1.5K, 2.2K, 3.7K</td> <td>1.5K, 2.2K, 3.7K</td> <td>0.75K, 1.5K, 2.2K, 3.7K</td> </tr> <tr> <td>A5AT03</td> <td>1.5K, 2.2K, 3.7K, 5.5K, 7.5K</td> <td>0.4K, 0.75K, 1.5K, 2.2K, 3.7K, 5.5K, 7.5K</td> <td>5.5K, 7.5K, 11K</td> <td>5.5K, 7.5K</td> <td>5.5K, 7.5K, 11K</td> <td>5.5K, 7.5K, 11K</td> </tr> <tr> <td>A5AT04</td> <td>11K, 15K, 18.5K, 22K</td> <td>11K, 15K, 18.5K, 22K</td> <td>18.5K, 22K</td> <td>18.5K, 22K</td> <td>22K</td> <td>22K</td> </tr> <tr> <td>A5AT05</td> <td>37K, 45K</td> <td>37K, 45K, 55K</td> <td>—</td> <td>55K</td> <td>—</td> <td>55K</td> </tr> </tbody> </table>	Type	Applicable Inverter	FR-AAT24	FR-A740-11K, 15K	Type	Mountable Models			Compatible Former Models				A720	A740	A220E	A240E	A120E	A140E	A5AT01	0.4K, 0.75K	—	0.4K, 0.75K	—	0.75K	—	A5AT02	0.4K, 0.75K, 1.5K, 2.2K, 3.7K	0.4K, 0.75K, 1.5K, 2.2K, 3.7K	1.5K, 2.2K, 3.7K	0.4K, 0.75K, 1.5K, 2.2K, 3.7K	1.5K, 2.2K, 3.7K	0.75K, 1.5K, 2.2K, 3.7K	A5AT03	1.5K, 2.2K, 3.7K, 5.5K, 7.5K	0.4K, 0.75K, 1.5K, 2.2K, 3.7K, 5.5K, 7.5K	5.5K, 7.5K, 11K	5.5K, 7.5K	5.5K, 7.5K, 11K	5.5K, 7.5K, 11K	A5AT04	11K, 15K, 18.5K, 22K	11K, 15K, 18.5K, 22K	18.5K, 22K	18.5K, 22K	22K	22K	A5AT05	37K, 45K	37K, 45K, 55K	—	55K	—	55K																																																																																																																																																																																
Type	Applicable Inverter																																																																																																																																																																																																																																					
FR-AAT24	FR-A740-11K, 15K																																																																																																																																																																																																																																					
Type	Mountable Models			Compatible Former Models																																																																																																																																																																																																																																		
	A720	A740	A220E	A240E	A120E	A140E																																																																																																																																																																																																																																
A5AT01	0.4K, 0.75K	—	0.4K, 0.75K	—	0.75K	—																																																																																																																																																																																																																																
A5AT02	0.4K, 0.75K, 1.5K, 2.2K, 3.7K	0.4K, 0.75K, 1.5K, 2.2K, 3.7K	1.5K, 2.2K, 3.7K	0.4K, 0.75K, 1.5K, 2.2K, 3.7K	1.5K, 2.2K, 3.7K	0.75K, 1.5K, 2.2K, 3.7K																																																																																																																																																																																																																																
A5AT03	1.5K, 2.2K, 3.7K, 5.5K, 7.5K	0.4K, 0.75K, 1.5K, 2.2K, 3.7K, 5.5K, 7.5K	5.5K, 7.5K, 11K	5.5K, 7.5K	5.5K, 7.5K, 11K	5.5K, 7.5K, 11K																																																																																																																																																																																																																																
A5AT04	11K, 15K, 18.5K, 22K	11K, 15K, 18.5K, 22K	18.5K, 22K	18.5K, 22K	22K	22K																																																																																																																																																																																																																																
A5AT05	37K, 45K	37K, 45K, 55K	—	55K	—	55K																																																																																																																																																																																																																																
AC reactor (for power coordination) FR-HAL-(H)□□K	<ul style="list-style-type: none"> Outline dimension <p style="text-align: right;">(Unit: mm)</p> <table border="1" data-bbox="343 1377 1061 1937"> <thead> <tr> <th rowspan="2">Model</th> <th rowspan="2">W</th> <th rowspan="2">D</th> <th rowspan="2">H</th> <th rowspan="2">Mass (kg)</th> <th rowspan="2">Model</th> <th rowspan="2">W</th> <th rowspan="2">D</th> <th rowspan="2">H</th> <th rowspan="2">Mass (kg)</th> </tr> <tr> <th colspan="4">200V</th> <th colspan="4">400V</th> </tr> </thead> <tbody> <tr><td>0.4K</td><td>104</td><td>72</td><td>99</td><td>0.6</td><td>H0.4K</td><td>135</td><td>59.6</td><td>115</td><td>1.5</td></tr> <tr><td>0.75K</td><td>104</td><td>74</td><td>99</td><td>0.8</td><td>H0.75K</td><td>135</td><td>59.6</td><td>115</td><td>1.5</td></tr> <tr><td>1.5K</td><td>104</td><td>77</td><td>99</td><td>1.1</td><td>H1.5K</td><td>135</td><td>59.6</td><td>115</td><td>1.5</td></tr> <tr><td>2.2K</td><td>115</td><td>77</td><td>115</td><td>1.5</td><td>H2.2K</td><td>135</td><td>59.6</td><td>115</td><td>1.5</td></tr> <tr><td>3.7K</td><td>115</td><td>83</td><td>115</td><td>2.2</td><td>H3.7K</td><td>135</td><td>70.6</td><td>115</td><td>2.5</td></tr> <tr><td>5.5K</td><td>115</td><td>83</td><td>115</td><td>2.3</td><td>H5.5K</td><td>160</td><td>72</td><td>142</td><td>3.5</td></tr> <tr><td>7.5K</td><td>130</td><td>100</td><td>135</td><td>4.2</td><td>H7.5K</td><td>160</td><td>91</td><td>142</td><td>5.0</td></tr> <tr><td>11K</td><td>160</td><td>111</td><td>164</td><td>5.2</td><td>H11K</td><td>160</td><td>91</td><td>146</td><td>6.0</td></tr> <tr><td>15K</td><td>160</td><td>126</td><td>167</td><td>7.0</td><td>H15K</td><td>220</td><td>105</td><td>195</td><td>9.0</td></tr> <tr><td>18.5K</td><td>160</td><td>175</td><td>128</td><td>7.1</td><td>H18.5K</td><td>220</td><td>170</td><td>215</td><td>9.0</td></tr> <tr><td>22K</td><td>185</td><td>158</td><td>150</td><td>9.0</td><td>H22K</td><td>220</td><td>170</td><td>215</td><td>9.5</td></tr> <tr><td>30K</td><td>185</td><td>168</td><td>150</td><td>9.7</td><td>H30K</td><td>220</td><td>170</td><td>215</td><td>11</td></tr> <tr><td>37K</td><td>210</td><td>174</td><td>175</td><td>12.9</td><td>H37K</td><td>220</td><td>170</td><td>214</td><td>12.5</td></tr> <tr><td>45K</td><td>210</td><td>191</td><td>175</td><td>16.4</td><td>H45K</td><td>280</td><td>165</td><td>245</td><td>15</td></tr> <tr><td>55K</td><td>210</td><td>201</td><td>175</td><td>17.4</td><td>H55K</td><td>280</td><td>170</td><td>245</td><td>18</td></tr> <tr><td>75K</td><td>240</td><td>213</td><td>210</td><td>23</td><td>H75K</td><td>205</td><td>208</td><td>170</td><td>20</td></tr> <tr><td>110K</td><td>330</td><td>258</td><td>325</td><td>40</td><td>H110K</td><td>240</td><td>220</td><td>225</td><td>28</td></tr> <tr><td></td><td></td><td></td><td></td><td></td><td>H185K</td><td>330</td><td>270</td><td>325</td><td>55</td></tr> <tr><td></td><td></td><td></td><td></td><td></td><td>H280K</td><td>330</td><td>320</td><td>325</td><td>80</td></tr> <tr><td></td><td></td><td></td><td></td><td></td><td>H355K</td><td>330</td><td>340</td><td>325</td><td>80</td></tr> <tr><td></td><td></td><td></td><td></td><td></td><td>H560K</td><td>450</td><td>635</td><td>540</td><td>190</td></tr> </tbody> </table>	Model	W	D	H	Mass (kg)	Model	W	D	H	Mass (kg)	200V				400V				0.4K	104	72	99	0.6	H0.4K	135	59.6	115	1.5	0.75K	104	74	99	0.8	H0.75K	135	59.6	115	1.5	1.5K	104	77	99	1.1	H1.5K	135	59.6	115	1.5	2.2K	115	77	115	1.5	H2.2K	135	59.6	115	1.5	3.7K	115	83	115	2.2	H3.7K	135	70.6	115	2.5	5.5K	115	83	115	2.3	H5.5K	160	72	142	3.5	7.5K	130	100	135	4.2	H7.5K	160	91	142	5.0	11K	160	111	164	5.2	H11K	160	91	146	6.0	15K	160	126	167	7.0	H15K	220	105	195	9.0	18.5K	160	175	128	7.1	H18.5K	220	170	215	9.0	22K	185	158	150	9.0	H22K	220	170	215	9.5	30K	185	168	150	9.7	H30K	220	170	215	11	37K	210	174	175	12.9	H37K	220	170	214	12.5	45K	210	191	175	16.4	H45K	280	165	245	15	55K	210	201	175	17.4	H55K	280	170	245	18	75K	240	213	210	23	H75K	205	208	170	20	110K	330	258	325	40	H110K	240	220	225	28						H185K	330	270	325	55						H280K	330	320	325	80						H355K	330	340	325	80						H560K	450	635	540	190	 <p>(Note) 1. Make selection according to the applied motor capacity. (When the inverter capacity is larger than the motor capacity, make selection according to the motor capacity)</p> <p>2. Power factor improving reactor (FR-BAL) can be used. Power factor improving effect FR-BAL approx. 90% FR-HAL approx. 88%</p> <p>3. Outline dimension drawing shown is a one of a typical model. The shape differs according to each models.</p> <p>4. Install AC reactor (FR-HAL) as follows. (H)55K or less : horizontal plane installation or vertical plane installation (H)75K or more : horizontal plane installation</p>
Model	W											D	H	Mass (kg)	Model	W	D	H	Mass (kg)																																																																																																																																																																																																																			
		200V				400V																																																																																																																																																																																																																																
0.4K	104	72	99	0.6	H0.4K	135	59.6	115	1.5																																																																																																																																																																																																																													
0.75K	104	74	99	0.8	H0.75K	135	59.6	115	1.5																																																																																																																																																																																																																													
1.5K	104	77	99	1.1	H1.5K	135	59.6	115	1.5																																																																																																																																																																																																																													
2.2K	115	77	115	1.5	H2.2K	135	59.6	115	1.5																																																																																																																																																																																																																													
3.7K	115	83	115	2.2	H3.7K	135	70.6	115	2.5																																																																																																																																																																																																																													
5.5K	115	83	115	2.3	H5.5K	160	72	142	3.5																																																																																																																																																																																																																													
7.5K	130	100	135	4.2	H7.5K	160	91	142	5.0																																																																																																																																																																																																																													
11K	160	111	164	5.2	H11K	160	91	146	6.0																																																																																																																																																																																																																													
15K	160	126	167	7.0	H15K	220	105	195	9.0																																																																																																																																																																																																																													
18.5K	160	175	128	7.1	H18.5K	220	170	215	9.0																																																																																																																																																																																																																													
22K	185	158	150	9.0	H22K	220	170	215	9.5																																																																																																																																																																																																																													
30K	185	168	150	9.7	H30K	220	170	215	11																																																																																																																																																																																																																													
37K	210	174	175	12.9	H37K	220	170	214	12.5																																																																																																																																																																																																																													
45K	210	191	175	16.4	H45K	280	165	245	15																																																																																																																																																																																																																													
55K	210	201	175	17.4	H55K	280	170	245	18																																																																																																																																																																																																																													
75K	240	213	210	23	H75K	205	208	170	20																																																																																																																																																																																																																													
110K	330	258	325	40	H110K	240	220	225	28																																																																																																																																																																																																																													
					H185K	330	270	325	55																																																																																																																																																																																																																													
					H280K	330	320	325	80																																																																																																																																																																																																																													
					H355K	330	340	325	80																																																																																																																																																																																																																													
					H560K	450	635	540	190																																																																																																																																																																																																																													

Name (type)	Specifications, Structure, etc.																																																																																																																																																																																																							
DC reactor (for power coordination) FR-HEL-(H)□□K	●Outline dimension (Unit: mm)																																																																																																																																																																																																							
	<table border="1"> <thead> <tr> <th rowspan="2">Model</th> <th rowspan="2">W</th> <th rowspan="2">D</th> <th rowspan="2">H</th> <th rowspan="2">Mass (kg)</th> <th rowspan="2">Model</th> <th rowspan="2">W</th> <th rowspan="2">D</th> <th rowspan="2">H</th> <th rowspan="2">Mass (kg)</th> </tr> <tr> <th>Model</th> <th>W</th> <th>D</th> <th>H</th> <th>Mass (kg)</th> </tr> </thead> <tbody> <tr><td rowspan="13">200V</td><td>0.4K</td><td>70</td><td>61</td><td>71</td><td>0.4</td><td>H0.4K</td><td>90</td><td>60</td><td>78</td><td>0.6</td></tr> <tr><td>0.75K</td><td>85</td><td>61</td><td>81</td><td>0.5</td><td>H0.75K</td><td>66</td><td>70</td><td>100</td><td>0.8</td></tr> <tr><td>1.5K</td><td>85</td><td>70</td><td>81</td><td>0.8</td><td>H1.5K</td><td>66</td><td>80</td><td>100</td><td>1</td></tr> <tr><td>2.2K</td><td>85</td><td>70</td><td>81</td><td>0.9</td><td>H2.2K</td><td>76</td><td>80</td><td>110</td><td>1.3</td></tr> <tr><td>3.7K</td><td>77</td><td>82</td><td>92</td><td>1.5</td><td>H3.7K</td><td>86</td><td>95</td><td>120</td><td>2.3</td></tr> <tr><td>5.5K</td><td>77</td><td>92</td><td>92</td><td>1.9</td><td>H5.5K</td><td>96</td><td>100</td><td>128</td><td>3</td></tr> <tr><td>7.5K</td><td>86</td><td>98</td><td>113</td><td>2.5</td><td>H7.5K</td><td>96</td><td>105</td><td>128</td><td>3.5</td></tr> <tr><td>11K</td><td>105</td><td>112</td><td>133</td><td>3.3</td><td>H11K</td><td>105</td><td>110</td><td>137</td><td>4.5</td></tr> <tr><td>15K</td><td>105</td><td>115</td><td>133</td><td>4.1</td><td>H15K</td><td>105</td><td>125</td><td>152</td><td>5</td></tr> <tr><td>18.5K</td><td>105</td><td>165</td><td>93</td><td>4.7</td><td>H18.5K</td><td>114</td><td>120</td><td>162</td><td>5</td></tr> <tr><td>22K</td><td>105</td><td>175</td><td>93</td><td>5.6</td><td>H22K</td><td>133</td><td>120</td><td>178</td><td>6</td></tr> <tr><td>30K</td><td>114</td><td>200</td><td>100</td><td>7.8</td><td>H30K</td><td>133</td><td>120</td><td>178</td><td>6.5</td></tr> <tr><td>37K</td><td>133</td><td>195</td><td>117</td><td>10</td><td>H37K</td><td>133</td><td>155</td><td>187</td><td>8.5</td></tr> <tr><td>45K</td><td>133</td><td>205</td><td>117</td><td>11</td><td>H45K</td><td>133</td><td>170</td><td>187</td><td>10</td></tr> <tr><td>55K</td><td>153</td><td>209</td><td>132</td><td>12.6</td><td>H55K</td><td>152</td><td>170</td><td>206</td><td>11.5</td></tr> </tbody> </table>	Model	W	D	H	Mass (kg)	Model	W	D	H	Mass (kg)	Model	W	D	H	Mass (kg)	200V	0.4K	70	61	71	0.4	H0.4K	90	60	78	0.6	0.75K	85	61	81	0.5	H0.75K	66	70	100	0.8	1.5K	85	70	81	0.8	H1.5K	66	80	100	1	2.2K	85	70	81	0.9	H2.2K	76	80	110	1.3	3.7K	77	82	92	1.5	H3.7K	86	95	120	2.3	5.5K	77	92	92	1.9	H5.5K	96	100	128	3	7.5K	86	98	113	2.5	H7.5K	96	105	128	3.5	11K	105	112	133	3.3	H11K	105	110	137	4.5	15K	105	115	133	4.1	H15K	105	125	152	5	18.5K	105	165	93	4.7	H18.5K	114	120	162	5	22K	105	175	93	5.6	H22K	133	120	178	6	30K	114	200	100	7.8	H30K	133	120	178	6.5	37K	133	195	117	10	H37K	133	155	187	8.5	45K	133	205	117	11	H45K	133	170	187	10	55K	153	209	132	12.6	H55K	152	170	206	11.5																																	
Model	W											D	H	Mass (kg)	Model	W		D	H	Mass (kg)																																																																																																																																																																																				
		Model	W	D	H	Mass (kg)																																																																																																																																																																																																		
200V	0.4K	70	61	71	0.4	H0.4K	90	60	78	0.6																																																																																																																																																																																														
	0.75K	85	61	81	0.5	H0.75K	66	70	100	0.8																																																																																																																																																																																														
	1.5K	85	70	81	0.8	H1.5K	66	80	100	1																																																																																																																																																																																														
	2.2K	85	70	81	0.9	H2.2K	76	80	110	1.3																																																																																																																																																																																														
	3.7K	77	82	92	1.5	H3.7K	86	95	120	2.3																																																																																																																																																																																														
	5.5K	77	92	92	1.9	H5.5K	96	100	128	3																																																																																																																																																																																														
	7.5K	86	98	113	2.5	H7.5K	96	105	128	3.5																																																																																																																																																																																														
	11K	105	112	133	3.3	H11K	105	110	137	4.5																																																																																																																																																																																														
	15K	105	115	133	4.1	H15K	105	125	152	5																																																																																																																																																																																														
	18.5K	105	165	93	4.7	H18.5K	114	120	162	5																																																																																																																																																																																														
	22K	105	175	93	5.6	H22K	133	120	178	6																																																																																																																																																																																														
	30K	114	200	100	7.8	H30K	133	120	178	6.5																																																																																																																																																																																														
	37K	133	195	117	10	H37K	133	155	187	8.5																																																																																																																																																																																														
45K	133	205	117	11	H45K	133	170	187	10																																																																																																																																																																																															
55K	153	209	132	12.6	H55K	152	170	206	11.5																																																																																																																																																																																															
<p>(Note) 1. Be sure to remove the jumper across the inverter terminals P/+P1. (A failure to do so will produce no power factor improving effect)</p> <p>2. The wiring length between the reactor and inverter should be within 5m.</p> <p>3. The size of the cables used should be equal to or larger than that of the power supply cables (R/L1, S/L2, T/L3).</p> <p>4. Make selection according to the motor capacity. (When the inverter capacity is larger than the motor capacity, make selection according to the motor capacity)</p> <p>5. Power factor improving reactor (FR-BEL) can be used. Power factor improving effect FR-BEL approx.95% FR-HEL approx.93%</p> <p>6. A DC reactor for the 75K or more is supplied with the inverter.</p> <p>7. Outline dimension drawing shown is a one of a typical model. The shape differs according to each models.</p> <p>8. Install DC reactor (FR-HEL) as follows. (H)55K or less : horizontal plane installation or vertical plane installation (H)75K or more : horizontal plane installation</p>																																																																																																																																																																																																								
Line noise filter FR-BSF01...for small capacities FR- BLF	●Outline dimension FR-BSF01 FR-BLF <p>(Note) 1. Each phase should be wound at least 3 times (4T, 4 turns) in the same direction. (The greater the number of turns, the more effective result is obtained.)</p> <p>2. When the thickness of the wire prevents winding, use at least 4 in series and ensure that the current passes through each phase in the same direction.</p> <p>3. Can be used on the output side in the same way as the input side.</p> <p>4. Please use FR-BSF01 for inverters with small capacities of 3.7K or less. Thick wires (38mm² or more) can not be used. In such cases, use the FR-BLF.</p>																																																																																																																																																																																																							
High-duty brake resistor FR-ABR-(H)□□	●Outline dimension (Unit: mm) <table border="1"> <thead> <tr> <th rowspan="2">Brake Resistor Type</th> <th rowspan="2">Permissible Brake Duty</th> <th colspan="4">Outline Dimension</th> <th rowspan="2">Resistance Value (Ω)</th> <th rowspan="2">Approx Mass (kg)</th> <th rowspan="2">Brake Resistor Type</th> <th rowspan="2">Permissible Brake Duty</th> <th colspan="4">Outline Dimension</th> <th rowspan="2">Resistance Value (Ω)</th> <th rowspan="2">Approx Mass (kg)</th> </tr> <tr> <th>W</th> <th>W1</th> <th>D</th> <th>H</th> <th>W</th> <th>W1</th> <th>D</th> <th>H</th> </tr> </thead> <tbody> <tr><td rowspan="9">200V</td><td>FR-ABR-0.4K</td><td>10%</td><td>140</td><td>500</td><td>40</td><td>21</td><td>200</td><td>0.2</td><td rowspan="9">400V</td><td>FR-ABR-H0.4K</td><td>10%</td><td>115</td><td>500</td><td>40</td><td>21</td><td>1200</td><td>0.2</td></tr> <tr><td>FR-ABR-0.75K</td><td>10%</td><td>215</td><td>500</td><td>40</td><td>21</td><td>100</td><td>0.4</td><td>FR-ABR-H0.75K</td><td>10%</td><td>140</td><td>500</td><td>40</td><td>21</td><td>700</td><td>0.2</td></tr> <tr><td>FR-ABR-2.2K*1</td><td>10%</td><td>240</td><td>500</td><td>50</td><td>26</td><td>60</td><td>0.5</td><td>FR-ABR-H1.5K</td><td>10%</td><td>215</td><td>500</td><td>40</td><td>21</td><td>350</td><td>0.4</td></tr> <tr><td>FR-ABR-3.7K</td><td>10%</td><td>215</td><td>500</td><td>61</td><td>33</td><td>40</td><td>0.8</td><td>FR-ABR-H2.2K</td><td>10%</td><td>240</td><td>500</td><td>50</td><td>26</td><td>250</td><td>0.5</td></tr> <tr><td>FR-ABR-5.5K</td><td>10%</td><td>335</td><td>500</td><td>61</td><td>33</td><td>25</td><td>1.3</td><td>FR-ABR-H3.7K</td><td>10%</td><td>215</td><td>500</td><td>61</td><td>33</td><td>150</td><td>0.8</td></tr> <tr><td>FR-ABR-7.5K</td><td>10%</td><td>400</td><td>500</td><td>80</td><td>40</td><td>20</td><td>2.2</td><td>FR-ABR-H5.5K</td><td>10%</td><td>335</td><td>500</td><td>61</td><td>33</td><td>110</td><td>1.3</td></tr> <tr><td>FR-ABR-11K</td><td>6%</td><td>400</td><td>700</td><td>100</td><td>50</td><td>13</td><td>3.5</td><td>FR-ABR-H7.5K</td><td>10%</td><td>400</td><td>500</td><td>80</td><td>40</td><td>75</td><td>2.2</td></tr> <tr><td>FR-ABR-15K*2</td><td>6%</td><td>300</td><td>700</td><td>100</td><td>50</td><td>18 (×1/2)</td><td>2.4 (×2)</td><td>FR-ABR-H11K</td><td>6%</td><td>400</td><td>700</td><td>100</td><td>50</td><td>52</td><td>3.2</td></tr> <tr><td>FR-ABR-22K*3</td><td>6%</td><td>400</td><td>700</td><td>100</td><td>50</td><td>13 (×1/2)</td><td>3.3 (×2)</td><td>FR-ABR-H15K*4</td><td>6%</td><td>300</td><td>700</td><td>100</td><td>50</td><td>18 (×2)</td><td>2.4 (×2)</td></tr> <tr><td></td><td></td><td></td><td></td><td></td><td></td><td></td><td></td><td>FR-ABR-H22K*5</td><td>6%</td><td>450</td><td>700</td><td>100</td><td>50</td><td>52 (×1/2)</td><td>3.3 (×2)</td></tr> </tbody> </table> <p>*1. For the 1.5K and 2.2K inverter. *2. For the 15K brake resistor, configure so that two 18Ω resistors are connected in parallel. *3. For the 22K brake resistor, configure so that two 13Ω resistors are connected in parallel. *4. For the H15K brake resistor, configure so that two 18Ω resistors are connected in series. FR-ABR-15K is indicated on the resistor. (same resistor as the 200V class 15K) *5. For the H22K brake resistor, configure so that two 52Ω resistors are connected in parallel.</p> <p>(Note) 1. When using the FR-ABR type brake resistor, remove the jumper across terminal PR-PX. Failure to remove will cause the brake resistor to overheat.</p> <p>2. The regenerative brake duty setting should be less than permissible brake duty in the table above.</p> <p>3. The temperature of the brake resistor becomes 300°C or more depending on the operation frequency, care must be taken for installation and heat dissipation.</p> <p>4. MYS type resistor can be also used. Note the permissible brake duty.</p> <p>5. Do not remove a jumper across terminal P/+ and P1 except when connecting a DC reactor.</p> <p>6. Install a thermal relay to prevent an overheat and burnout of the brake resistor.</p>														Brake Resistor Type	Permissible Brake Duty	Outline Dimension				Resistance Value (Ω)	Approx Mass (kg)	Brake Resistor Type	Permissible Brake Duty	Outline Dimension				Resistance Value (Ω)	Approx Mass (kg)	W	W1	D	H	W	W1	D	H	200V	FR-ABR-0.4K	10%	140	500	40	21	200	0.2	400V	FR-ABR-H0.4K	10%	115	500	40	21	1200	0.2	FR-ABR-0.75K	10%	215	500	40	21	100	0.4	FR-ABR-H0.75K	10%	140	500	40	21	700	0.2	FR-ABR-2.2K*1	10%	240	500	50	26	60	0.5	FR-ABR-H1.5K	10%	215	500	40	21	350	0.4	FR-ABR-3.7K	10%	215	500	61	33	40	0.8	FR-ABR-H2.2K	10%	240	500	50	26	250	0.5	FR-ABR-5.5K	10%	335	500	61	33	25	1.3	FR-ABR-H3.7K	10%	215	500	61	33	150	0.8	FR-ABR-7.5K	10%	400	500	80	40	20	2.2	FR-ABR-H5.5K	10%	335	500	61	33	110	1.3	FR-ABR-11K	6%	400	700	100	50	13	3.5	FR-ABR-H7.5K	10%	400	500	80	40	75	2.2	FR-ABR-15K*2	6%	300	700	100	50	18 (×1/2)	2.4 (×2)	FR-ABR-H11K	6%	400	700	100	50	52	3.2	FR-ABR-22K*3	6%	400	700	100	50	13 (×1/2)	3.3 (×2)	FR-ABR-H15K*4	6%	300	700	100	50	18 (×2)	2.4 (×2)									FR-ABR-H22K*5	6%	450	700	100	50	52 (×1/2)	3.3 (×2)
Brake Resistor Type	Permissible Brake Duty	Outline Dimension				Resistance Value (Ω)	Approx Mass (kg)	Brake Resistor Type	Permissible Brake Duty	Outline Dimension				Resistance Value (Ω)			Approx Mass (kg)																																																																																																																																																																																							
		W	W1	D	H					W	W1	D	H																																																																																																																																																																																											
200V	FR-ABR-0.4K	10%	140	500	40	21	200	0.2	400V	FR-ABR-H0.4K	10%	115	500	40	21	1200	0.2																																																																																																																																																																																							
	FR-ABR-0.75K	10%	215	500	40	21	100	0.4		FR-ABR-H0.75K	10%	140	500	40	21	700	0.2																																																																																																																																																																																							
	FR-ABR-2.2K*1	10%	240	500	50	26	60	0.5		FR-ABR-H1.5K	10%	215	500	40	21	350	0.4																																																																																																																																																																																							
	FR-ABR-3.7K	10%	215	500	61	33	40	0.8		FR-ABR-H2.2K	10%	240	500	50	26	250	0.5																																																																																																																																																																																							
	FR-ABR-5.5K	10%	335	500	61	33	25	1.3		FR-ABR-H3.7K	10%	215	500	61	33	150	0.8																																																																																																																																																																																							
	FR-ABR-7.5K	10%	400	500	80	40	20	2.2		FR-ABR-H5.5K	10%	335	500	61	33	110	1.3																																																																																																																																																																																							
	FR-ABR-11K	6%	400	700	100	50	13	3.5		FR-ABR-H7.5K	10%	400	500	80	40	75	2.2																																																																																																																																																																																							
	FR-ABR-15K*2	6%	300	700	100	50	18 (×1/2)	2.4 (×2)		FR-ABR-H11K	6%	400	700	100	50	52	3.2																																																																																																																																																																																							
	FR-ABR-22K*3	6%	400	700	100	50	13 (×1/2)	3.3 (×2)		FR-ABR-H15K*4	6%	300	700	100	50	18 (×2)	2.4 (×2)																																																																																																																																																																																							
								FR-ABR-H22K*5	6%	450	700	100	50	52 (×1/2)	3.3 (×2)																																																																																																																																																																																									

Features
Peripheral Devices
Standard Specifications
Outline Dimension Drawings
Terminal Connection Diagram Terminal Specification Explanation
Operation Panel
Parameter List
Explanations of Parameters
Protective Functions
Options
Instructions
Motor
Compatibility
Warranty
Inquiry

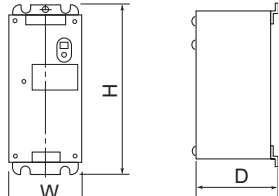
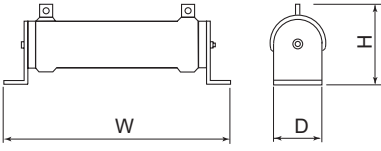
Name (type)	Specifications, Structure, etc.																																																																																											
Brake unit BU-(H)□□ Electrical-discharge resistor GZG type GRZG type	<ul style="list-style-type: none"> ● A brake unit is an option that fully enhances the regenerative braking capability of the inverter, and should be used with an electrical-discharge resistor. ● Brake units should be selected according to the required braking torque. 																																																																																											
	● Brake unit selection table																																																																																											
	<table border="1"> <thead> <tr> <th data-bbox="338 318 414 365">Voltage</th> <th data-bbox="418 318 555 365">Motor(kW) Braking torque</th> <th data-bbox="558 318 619 365">0.4 0.75</th> <th data-bbox="622 318 683 365">1.5</th> <th data-bbox="686 318 746 365">2.2</th> <th data-bbox="750 318 810 365">3.7</th> <th data-bbox="813 318 874 365">5.5</th> <th data-bbox="877 318 938 365">7.5</th> <th data-bbox="941 318 1002 365">11</th> <th data-bbox="1005 318 1066 365">15</th> <th data-bbox="1069 318 1129 365">18.5</th> <th data-bbox="1133 318 1193 365">22</th> <th data-bbox="1197 318 1257 365">30</th> <th data-bbox="1260 318 1321 365">37</th> <th data-bbox="1324 318 1385 365">45</th> <th data-bbox="1388 318 1449 365">55</th> </tr> </thead> <tbody> <tr> <td data-bbox="338 380 414 414" rowspan="2">200V output</td> <td data-bbox="418 380 555 414">50% 30s</td> <td colspan="2" data-bbox="558 380 683 414">BU-1500</td> <td colspan="2" data-bbox="686 380 810 414">BU-3700</td> <td colspan="2" data-bbox="813 380 938 414">BU-7.5K</td> <td colspan="2" data-bbox="941 380 1066 414">BU-15K</td> <td colspan="3" data-bbox="1069 380 1193 414">2×BU-15K</td> <td colspan="2" data-bbox="1197 380 1321 414">3×BU-15K</td> <td colspan="1" data-bbox="1324 380 1449 414">4×BU-15K</td> </tr> <tr> <td data-bbox="418 418 555 452">100% 30s</td> <td data-bbox="558 418 619 452">BU-1500</td> <td data-bbox="622 418 683 452">BU-3700</td> <td colspan="2" data-bbox="686 418 810 452">BU-7.5K</td> <td colspan="2" data-bbox="813 418 938 452">BU-15K</td> <td colspan="2" data-bbox="941 418 1066 452">2×BU-15K</td> <td colspan="2" data-bbox="1069 418 1193 452">3×BU-15K</td> <td colspan="1" data-bbox="1197 418 1257 452">4×BU-15K</td> <td colspan="1" data-bbox="1260 418 1321 452">5×BU-15K</td> <td colspan="1" data-bbox="1324 418 1385 452">6×BU-15K</td> <td colspan="1" data-bbox="1388 418 1449 452">7×BU-15K</td> </tr> <tr> <td data-bbox="338 456 414 490" rowspan="2">400V output</td> <td data-bbox="418 456 555 490">50% 30s</td> <td colspan="2" data-bbox="558 456 683 490">*</td> <td colspan="4" data-bbox="686 456 938 490">BU-H7.5K</td> <td colspan="2" data-bbox="941 456 1066 490">BU-H15K</td> <td colspan="3" data-bbox="1069 456 1193 490">BU-H30K</td> <td colspan="3" data-bbox="1197 456 1449 490">2×BU-H30K</td> </tr> <tr> <td data-bbox="418 495 555 528">100% 30s</td> <td colspan="2" data-bbox="558 495 683 528">*</td> <td colspan="2" data-bbox="686 495 810 528">BU-H7.5K</td> <td colspan="2" data-bbox="813 495 938 528">BU-H15K</td> <td colspan="2" data-bbox="941 495 1066 528">BU-H30K</td> <td colspan="2" data-bbox="1069 495 1193 528">2×BU-H30K</td> <td colspan="2" data-bbox="1197 495 1321 528">3×BU-H30K</td> <td colspan="1" data-bbox="1324 495 1449 528">4×BU-H30K</td> </tr> </tbody> </table>															Voltage	Motor(kW) Braking torque	0.4 0.75	1.5	2.2	3.7	5.5	7.5	11	15	18.5	22	30	37	45	55	200V output	50% 30s	BU-1500		BU-3700		BU-7.5K		BU-15K		2×BU-15K			3×BU-15K		4×BU-15K	100% 30s	BU-1500	BU-3700	BU-7.5K		BU-15K		2×BU-15K		3×BU-15K		4×BU-15K	5×BU-15K	6×BU-15K	7×BU-15K	400V output	50% 30s	*		BU-H7.5K				BU-H15K		BU-H30K			2×BU-H30K			100% 30s	*		BU-H7.5K		BU-H15K		BU-H30K		2×BU-H30K		3×BU-H30K		4×BU-H30K
	Voltage	Motor(kW) Braking torque	0.4 0.75	1.5	2.2	3.7	5.5	7.5	11	15	18.5	22	30	37	45	55																																																																												
	200V output	50% 30s	BU-1500		BU-3700		BU-7.5K		BU-15K		2×BU-15K			3×BU-15K		4×BU-15K																																																																												
		100% 30s	BU-1500	BU-3700	BU-7.5K		BU-15K		2×BU-15K		3×BU-15K		4×BU-15K	5×BU-15K	6×BU-15K	7×BU-15K																																																																												
	400V output	50% 30s	*		BU-H7.5K				BU-H15K		BU-H30K			2×BU-H30K																																																																														
		100% 30s	*		BU-H7.5K		BU-H15K		BU-H30K		2×BU-H30K		3×BU-H30K		4×BU-H30K																																																																													
	* The inverter of 1.5K or less with 400V output can not be used in combination with a brake unit. To use in combination with a brake unit, use the inverter of 2.2K or more.																																																																																											
	● Combination of brake unit and electrical discharge resistor																																																																																											
<table border="1"> <thead> <tr> <th data-bbox="338 645 414 678">Voltage</th> <th data-bbox="418 645 526 678">Brake Unit</th> <th data-bbox="529 645 746 678">Resistor Type</th> <th data-bbox="750 645 874 678">Used Cable (P, N)</th> <th data-bbox="877 645 954 678">Voltage</th> <th data-bbox="957 645 1066 678">Brake Unit</th> <th data-bbox="1069 645 1286 678">Resistor Type</th> <th data-bbox="1289 645 1414 678">Used Cable (P, N)</th> </tr> </thead> <tbody> <tr> <td data-bbox="338 694 414 840" rowspan="4">200V output</td> <td data-bbox="418 694 526 728">BU-1500</td> <td data-bbox="529 694 746 728">GZG300W-50Ω (one)</td> <td data-bbox="750 694 874 728">2mm²</td> <td data-bbox="877 694 954 840" rowspan="4">400V output</td> <td data-bbox="957 694 1066 728">BU-H7.5K</td> <td data-bbox="1069 694 1286 728">GRZG200-10Ω (six in series)</td> <td data-bbox="1289 694 1414 728">2mm²</td> </tr> <tr> <td data-bbox="418 732 526 766">BU-3700</td> <td data-bbox="529 732 746 766">GRZG200-10Ω (three in series)</td> <td data-bbox="750 732 874 766">2mm²</td> <td data-bbox="957 732 1066 766">BU-H15K</td> <td data-bbox="1069 732 1286 766">GRZG300-5Ω (eight in series)</td> <td data-bbox="1289 732 1414 766">3.5mm²</td> </tr> <tr> <td data-bbox="418 770 526 804">BU-7.5K</td> <td data-bbox="529 770 746 804">GRZG300-5Ω (four in series)</td> <td data-bbox="750 770 874 804">3.5mm²</td> <td data-bbox="957 770 1066 804">BU-H30K</td> <td data-bbox="1069 770 1286 804">GRZG400-10Ω (twelve in series)</td> <td data-bbox="1289 770 1414 804">3.5mm²</td> </tr> <tr> <td data-bbox="418 808 526 842">BU-15K</td> <td data-bbox="529 808 746 842">GRZG400-2Ω (six in series)</td> <td data-bbox="750 808 874 842">3.5mm²</td> <td></td> <td></td> <td></td> </tr> </tbody> </table>															Voltage	Brake Unit	Resistor Type	Used Cable (P, N)	Voltage	Brake Unit	Resistor Type	Used Cable (P, N)	200V output	BU-1500	GZG300W-50Ω (one)	2mm ²	400V output	BU-H7.5K	GRZG200-10Ω (six in series)	2mm ²	BU-3700	GRZG200-10Ω (three in series)	2mm ²	BU-H15K	GRZG300-5Ω (eight in series)	3.5mm ²	BU-7.5K	GRZG300-5Ω (four in series)	3.5mm ²	BU-H30K	GRZG400-10Ω (twelve in series)	3.5mm ²	BU-15K	GRZG400-2Ω (six in series)	3.5mm ²																																															
Voltage	Brake Unit	Resistor Type	Used Cable (P, N)	Voltage	Brake Unit	Resistor Type	Used Cable (P, N)																																																																																					
200V output	BU-1500	GZG300W-50Ω (one)	2mm ²	400V output	BU-H7.5K	GRZG200-10Ω (six in series)	2mm ²																																																																																					
	BU-3700	GRZG200-10Ω (three in series)	2mm ²		BU-H15K	GRZG300-5Ω (eight in series)	3.5mm ²																																																																																					
	BU-7.5K	GRZG300-5Ω (four in series)	3.5mm ²		BU-H30K	GRZG400-10Ω (twelve in series)	3.5mm ²																																																																																					
	BU-15K	GRZG400-2Ω (six in series)	3.5mm ²																																																																																									
● Brake unit																																																																																												
																																																																																												
● Electrical-discharge resistor																																																																																												
 <table border="1" data-bbox="375 1182 798 1276"> <thead> <tr> <th>Type</th> <th>W</th> <th>D</th> <th>H</th> </tr> </thead> <tbody> <tr> <td>BU-1500,3700,7.5K,15K</td> <td>100</td> <td>128</td> <td>240</td> </tr> <tr> <td>BU-H7.5K,H15K,H30K</td> <td>160</td> <td>145</td> <td>240</td> </tr> </tbody> </table> <table border="1" data-bbox="933 1131 1316 1288"> <thead> <tr> <th>Type</th> <th>W</th> <th>D</th> <th>H</th> </tr> </thead> <tbody> <tr> <td>GZG300W</td> <td>335</td> <td>40</td> <td>78</td> </tr> <tr> <td>GRZG200</td> <td>306</td> <td>26</td> <td>55</td> </tr> <tr> <td>GRZG300</td> <td>334</td> <td>40</td> <td>79</td> </tr> <tr> <td>GRZG400</td> <td>411</td> <td>40</td> <td>79</td> </tr> </tbody> </table>															Type	W	D	H	BU-1500,3700,7.5K,15K	100	128	240	BU-H7.5K,H15K,H30K	160	145	240	Type	W	D	H	GZG300W	335	40	78	GRZG200	306	26	55	GRZG300	334	40	79	GRZG400	411	40	79																																														
Type	W	D	H																																																																																									
BU-1500,3700,7.5K,15K	100	128	240																																																																																									
BU-H7.5K,H15K,H30K	160	145	240																																																																																									
Type	W	D	H																																																																																									
GZG300W	335	40	78																																																																																									
GRZG200	306	26	55																																																																																									
GRZG300	334	40	79																																																																																									
GRZG400	411	40	79																																																																																									
(Note) 1. Connect so that the terminal symbols of the inverter and brake unit match with each other. Incorrect connection will damage the inverter. 2. Minimize the cable length between the inverter and brake unit and the electrical-discharge resistor and brake unit. Use a twisted cable when the wiring length exceeds 2m. (If twisted cables are used, the wiring length should be within 5m.)																																																																																												
● Handling precautions																																																																																												
1. The thermal relay in the brake unit will trip if the rated torque is continuously output. After a trip, reset the inverter and increase its deceleration time setting. 2. The maximum temperature rise of the electrical-discharge resistor is 100°C. Use heat-resistant wires and wire to avoid contact with resistors.																																																																																												

Name (type)		Specifications, Structure, etc.																																																																																																																																																																																																																	
Brake unit FR-BU-(H)□□□ Resistor unit FR-BR-(H)□□□	<ul style="list-style-type: none"> ● A brake unit and resistor unit are options that will fully exhibit the regenerative braking capability of the inverter and are always used as a set. ● There are six different brake units as in the following table, from which make selection according to the necessary braking torque and deceleration time. ● The brake unit is equipped with a seven-segment LED that displays the duty (%ED) and alarm. ● Brake unit selection table <ul style="list-style-type: none"> ● %ED at short-time rating when braking torque is 100% <table border="1"> <thead> <tr> <th>Motor Capacity</th> <th>5.5kW</th> <th>7.5kW</th> <th>11kW</th> <th>15kW</th> <th>18.5kW</th> <th>22kW</th> <th>30kW</th> <th>37kW</th> <th>45kW</th> <th>55kW</th> </tr> </thead> <tbody> <tr> <td rowspan="2">Inverter</td> <td>200V</td> <td>5.5K</td> <td>7.5K</td> <td>11K</td> <td>15K</td> <td>18.5K</td> <td>22K</td> <td>30K</td> <td>37K</td> <td>45K</td> <td>55K</td> </tr> <tr> <td>400V</td> <td>5.5K</td> <td>7.5K</td> <td>11K</td> <td>15K</td> <td>18.5K</td> <td>22K</td> <td>30K</td> <td>37K</td> <td>45K</td> <td>55K</td> </tr> <tr> <td rowspan="6">Brake unit</td> <td rowspan="3">200V</td> <td>FR-BU-15K</td> <td>%ED</td> <td>80</td> <td>40</td> <td>15</td> <td>10</td> <td>—</td> <td>—</td> <td>—</td> <td>—</td> </tr> <tr> <td>FR-BU-30K</td> <td>%ED</td> <td>—</td> <td>—</td> <td>65</td> <td>30</td> <td>25</td> <td>15</td> <td>10</td> <td>—</td> </tr> <tr> <td>FR-BU-55K</td> <td>%ED</td> <td>—</td> <td>—</td> <td>—</td> <td>—</td> <td>90</td> <td>60</td> <td>30</td> <td>20</td> <td>15</td> </tr> <tr> <td rowspan="3">400V</td> <td>FR-BU-H15K</td> <td>%ED</td> <td>80</td> <td>40</td> <td>15</td> <td>10</td> <td>—</td> <td>—</td> <td>—</td> <td>—</td> </tr> <tr> <td>FR-BU-H30K</td> <td>%ED</td> <td>—</td> <td>—</td> <td>65</td> <td>30</td> <td>25</td> <td>15</td> <td>10</td> <td>—</td> </tr> <tr> <td>FR-BU-H55K</td> <td>%ED</td> <td>—</td> <td>—</td> <td>—</td> <td>—</td> <td>90</td> <td>60</td> <td>30</td> <td>20</td> <td>15</td> </tr> </tbody> </table> ● Braking torque (%) at short-time rating when 10%ED is 15s <table border="1"> <thead> <tr> <th>Motor Capacity</th> <th>5.5kW</th> <th>7.5kW</th> <th>11kW</th> <th>15kW</th> <th>18.5kW</th> <th>22kW</th> <th>30kW</th> <th>37kW</th> <th>45kW</th> <th>55kW</th> </tr> </thead> <tbody> <tr> <td rowspan="2">Inverter</td> <td>200V</td> <td>5.5K</td> <td>7.5K</td> <td>11K</td> <td>15K</td> <td>18.5K</td> <td>22K</td> <td>30K</td> <td>37K</td> <td>45K</td> <td>55K</td> </tr> <tr> <td>400V</td> <td>5.5K</td> <td>7.5K</td> <td>11K</td> <td>15K</td> <td>18.5K</td> <td>22K</td> <td>30K</td> <td>37K</td> <td>45K</td> <td>55K</td> </tr> <tr> <td rowspan="6">Brake unit</td> <td rowspan="3">200V</td> <td>FR-BU-15K</td> <td>Braking Torque (%)</td> <td>280</td> <td>200</td> <td>120</td> <td>100</td> <td>80</td> <td>70</td> <td>—</td> <td>—</td> </tr> <tr> <td>FR-BU-30K</td> <td>Braking Torque (%)</td> <td>—</td> <td>—</td> <td>260</td> <td>180</td> <td>160</td> <td>130</td> <td>100</td> <td>80</td> <td>70</td> </tr> <tr> <td>FR-BU-55K</td> <td>Braking Torque (%)</td> <td>—</td> <td>—</td> <td>—</td> <td>—</td> <td>300</td> <td>250</td> <td>180</td> <td>150</td> <td>120</td> </tr> <tr> <td rowspan="3">400V</td> <td>FR-BU-H15K</td> <td>Braking Torque (%)</td> <td>280</td> <td>200</td> <td>120</td> <td>100</td> <td>80</td> <td>70</td> <td>—</td> <td>—</td> </tr> <tr> <td>FR-BU-H30K</td> <td>Braking Torque (%)</td> <td>—</td> <td>—</td> <td>260</td> <td>180</td> <td>160</td> <td>130</td> <td>100</td> <td>80</td> <td>70</td> </tr> <tr> <td>FR-BU-H55K</td> <td>Braking Torque (%)</td> <td>—</td> <td>—</td> <td>—</td> <td>—</td> <td>300</td> <td>250</td> <td>180</td> <td>150</td> <td>120</td> </tr> </tbody> </table> 											Motor Capacity	5.5kW	7.5kW	11kW	15kW	18.5kW	22kW	30kW	37kW	45kW	55kW	Inverter	200V	5.5K	7.5K	11K	15K	18.5K	22K	30K	37K	45K	55K	400V	5.5K	7.5K	11K	15K	18.5K	22K	30K	37K	45K	55K	Brake unit	200V	FR-BU-15K	%ED	80	40	15	10	—	—	—	—	FR-BU-30K	%ED	—	—	65	30	25	15	10	—	FR-BU-55K	%ED	—	—	—	—	90	60	30	20	15	400V	FR-BU-H15K	%ED	80	40	15	10	—	—	—	—	FR-BU-H30K	%ED	—	—	65	30	25	15	10	—	FR-BU-H55K	%ED	—	—	—	—	90	60	30	20	15	Motor Capacity	5.5kW	7.5kW	11kW	15kW	18.5kW	22kW	30kW	37kW	45kW	55kW	Inverter	200V	5.5K	7.5K	11K	15K	18.5K	22K	30K	37K	45K	55K	400V	5.5K	7.5K	11K	15K	18.5K	22K	30K	37K	45K	55K	Brake unit	200V	FR-BU-15K	Braking Torque (%)	280	200	120	100	80	70	—	—	FR-BU-30K	Braking Torque (%)	—	—	260	180	160	130	100	80	70	FR-BU-55K	Braking Torque (%)	—	—	—	—	300	250	180	150	120	400V	FR-BU-H15K	Braking Torque (%)	280	200	120	100	80	70	—	—	FR-BU-H30K	Braking Torque (%)	—	—	260	180	160	130	100	80	70	FR-BU-H55K	Braking Torque (%)	—	—	—	—	300	250	180	150	120
	Motor Capacity	5.5kW	7.5kW	11kW	15kW	18.5kW	22kW	30kW	37kW	45kW	55kW																																																																																																																																																																																																								
	Inverter	200V	5.5K	7.5K	11K	15K	18.5K	22K	30K	37K	45K	55K																																																																																																																																																																																																							
		400V	5.5K	7.5K	11K	15K	18.5K	22K	30K	37K	45K	55K																																																																																																																																																																																																							
	Brake unit	200V	FR-BU-15K	%ED	80	40	15	10	—	—	—	—																																																																																																																																																																																																							
			FR-BU-30K	%ED	—	—	65	30	25	15	10	—																																																																																																																																																																																																							
			FR-BU-55K	%ED	—	—	—	—	90	60	30	20	15																																																																																																																																																																																																						
		400V	FR-BU-H15K	%ED	80	40	15	10	—	—	—	—																																																																																																																																																																																																							
			FR-BU-H30K	%ED	—	—	65	30	25	15	10	—																																																																																																																																																																																																							
			FR-BU-H55K	%ED	—	—	—	—	90	60	30	20	15																																																																																																																																																																																																						
Motor Capacity	5.5kW	7.5kW	11kW	15kW	18.5kW	22kW	30kW	37kW	45kW	55kW																																																																																																																																																																																																									
Inverter	200V	5.5K	7.5K	11K	15K	18.5K	22K	30K	37K	45K	55K																																																																																																																																																																																																								
	400V	5.5K	7.5K	11K	15K	18.5K	22K	30K	37K	45K	55K																																																																																																																																																																																																								
Brake unit	200V	FR-BU-15K	Braking Torque (%)	280	200	120	100	80	70	—	—																																																																																																																																																																																																								
		FR-BU-30K	Braking Torque (%)	—	—	260	180	160	130	100	80	70																																																																																																																																																																																																							
		FR-BU-55K	Braking Torque (%)	—	—	—	—	300	250	180	150	120																																																																																																																																																																																																							
	400V	FR-BU-H15K	Braking Torque (%)	280	200	120	100	80	70	—	—																																																																																																																																																																																																								
		FR-BU-H30K	Braking Torque (%)	—	—	260	180	160	130	100	80	70																																																																																																																																																																																																							
		FR-BU-H55K	Braking Torque (%)	—	—	—	—	300	250	180	150	120																																																																																																																																																																																																							
<ul style="list-style-type: none"> ● Outline dimension <table border="1"> <thead> <tr> <th rowspan="2"></th> <th colspan="4">Brake Unit</th> <th colspan="4">Resistor Unit</th> </tr> <tr> <th>Type</th> <th>W</th> <th>H</th> <th>D</th> <th>Type</th> <th>W</th> <th>H</th> <th>D</th> </tr> </thead> <tbody> <tr> <td rowspan="3">200V</td> <td>FR-BU-15K</td> <td>100</td> <td>240</td> <td>128</td> <td>FR-BR-15K</td> <td>170</td> <td>450</td> <td>220</td> </tr> <tr> <td>FR-BU-30K</td> <td>160</td> <td>240</td> <td>128</td> <td>FR-BR-30K</td> <td>340</td> <td>600</td> <td>220</td> </tr> <tr> <td>FR-BU-55K</td> <td>265</td> <td>240</td> <td>128</td> <td>FR-BR-55K</td> <td>480</td> <td>700</td> <td>450</td> </tr> <tr> <td rowspan="3">400V</td> <td>FR-BU-H15K</td> <td>160</td> <td>240</td> <td>128</td> <td>FR-BR-H15K</td> <td>170</td> <td>450</td> <td>220</td> </tr> <tr> <td>FR-BU-H30K</td> <td>160</td> <td>240</td> <td>128</td> <td>FR-BR-H30K</td> <td>340</td> <td>600</td> <td>220</td> </tr> <tr> <td>FR-BU-H55K</td> <td>265</td> <td>240</td> <td>128</td> <td>FR-BR-H55K</td> <td>480</td> <td>700</td> <td>450</td> </tr> </tbody> </table> 												Brake Unit				Resistor Unit				Type	W	H	D	Type	W	H	D	200V	FR-BU-15K	100	240	128	FR-BR-15K	170	450	220	FR-BU-30K	160	240	128	FR-BR-30K	340	600	220	FR-BU-55K	265	240	128	FR-BR-55K	480	700	450	400V	FR-BU-H15K	160	240	128	FR-BR-H15K	170	450	220	FR-BU-H30K	160	240	128	FR-BR-H30K	340	600	220	FR-BU-H55K	265	240	128	FR-BR-H55K	480	700	450																																																																																																																																						
	Brake Unit				Resistor Unit																																																																																																																																																																																																														
	Type	W	H	D	Type	W	H	D																																																																																																																																																																																																											
200V	FR-BU-15K	100	240	128	FR-BR-15K	170	450	220																																																																																																																																																																																																											
	FR-BU-30K	160	240	128	FR-BR-30K	340	600	220																																																																																																																																																																																																											
	FR-BU-55K	265	240	128	FR-BR-55K	480	700	450																																																																																																																																																																																																											
400V	FR-BU-H15K	160	240	128	FR-BR-H15K	170	450	220																																																																																																																																																																																																											
	FR-BU-H30K	160	240	128	FR-BR-H30K	340	600	220																																																																																																																																																																																																											
	FR-BU-H55K	265	240	128	FR-BR-H55K	480	700	450																																																																																																																																																																																																											
<ul style="list-style-type: none"> ● Brake unit and resistor unit combinations and used wires <table border="1"> <thead> <tr> <th></th> <th>Brake Unit Type</th> <th>Resistor Unit Type</th> <th>Wire (P/+ -P/+ , N-/N- , P/+ -P , PR-PR)</th> </tr> </thead> <tbody> <tr> <td rowspan="3">200V</td> <td>FR-BU-15K</td> <td>FR-BR-15K</td> <td>3.5mm²</td> </tr> <tr> <td>FR-BU-30K</td> <td>FR-BR-30K</td> <td>5.5mm²</td> </tr> <tr> <td>FR-BU-55K</td> <td>FR-BR-55K</td> <td>14mm²</td> </tr> <tr> <td rowspan="3">400V</td> <td>FR-BU-H15K</td> <td>FR-BR-H15K</td> <td>3.5mm²</td> </tr> <tr> <td>FR-BU-H30K</td> <td>FR-BR-H30K</td> <td>3.5mm²</td> </tr> <tr> <td>FR-BU-H55K</td> <td>FR-BR-H55K</td> <td>5.5mm²</td> </tr> </tbody> </table> <p>(Note) 1. The maximum temperature rise of the resistor unit is 100°C. Therefore, use heat-resistant wires (such as glass wires).</p> <p>Use the wires of the above recommended size or larger.</p> 												Brake Unit Type	Resistor Unit Type	Wire (P/+ -P/+ , N-/N- , P/+ -P , PR-PR)	200V	FR-BU-15K	FR-BR-15K	3.5mm ²	FR-BU-30K	FR-BR-30K	5.5mm ²	FR-BU-55K	FR-BR-55K	14mm ²	400V	FR-BU-H15K	FR-BR-H15K	3.5mm ²	FR-BU-H30K	FR-BR-H30K	3.5mm ²	FR-BU-H55K	FR-BR-H55K	5.5mm ²																																																																																																																																																																																	
	Brake Unit Type	Resistor Unit Type	Wire (P/+ -P/+ , N-/N- , P/+ -P , PR-PR)																																																																																																																																																																																																																
200V	FR-BU-15K	FR-BR-15K	3.5mm ²																																																																																																																																																																																																																
	FR-BU-30K	FR-BR-30K	5.5mm ²																																																																																																																																																																																																																
	FR-BU-55K	FR-BR-55K	14mm ²																																																																																																																																																																																																																
400V	FR-BU-H15K	FR-BR-H15K	3.5mm ²																																																																																																																																																																																																																
	FR-BU-H30K	FR-BR-H30K	3.5mm ²																																																																																																																																																																																																																
	FR-BU-H55K	FR-BR-H55K	5.5mm ²																																																																																																																																																																																																																
<ul style="list-style-type: none"> ● Connection example 																																																																																																																																																																																																																			
<ul style="list-style-type: none"> ● Connection example <p>Minimize the cable length between the inverter and brake unit and the resistor unit and brake unit. Use a twisted cable when the wiring length exceeds 5m. (If twisted wires are used, the distance should be within 10m.) Use the wires of the above recommended size or larger.</p>																																																																																																																																																																																																																			
<ul style="list-style-type: none"> *1. Connect the inverter terminals (P, N) and brake unit (FR-BU (H)) terminals so that their terminal signals match with each other. (Incorrect connection will damage the inverter.) *2. When the power supply is 400V class, install a step-down transformer. *3. Be sure to remove a jumper across terminal PR-PX when using the FR-BU with the inverter of 7.5K or less. Do not remove a jumper across terminal P/+ and P1 except when connecting a DC reactor. 																																																																																																																																																																																																																			

- Features
- Peripheral Devices
- Standard Specifications
- Outline Dimension Drawings
- Terminal Connection Diagram Terminal Specification Explanation
- Operation Panel
- Parameter List
- Explanations of Parameters
- Protective Functions
- Options
- Instructions
- Motor
- Compatibility
- Warranty
- Inquiry

Name (type)	Specifications, Structure, etc.																																																																																																																									
Brake unit MT-BU5-(H)□□K Resistor unit MT-BR5-(H)□□K	<ul style="list-style-type: none"> The brake unit and resistor unit are options that will fully exhibit the regenerative braking capability of the inverter. Use them as a set. There are six different brake units as in the following table, from which make selection according to the deceleration time. When the brake unit duty (%ED) excess and an alarm occur, errors appear in the inverter. 																																																																																																																									
	<ul style="list-style-type: none"> Brake unit selection table %ED at short-time rating when braking torque is 100% 																																																																																																																									
	<table border="1" style="width:100%; border-collapse: collapse; text-align: center;"> <thead> <tr> <th colspan="2">Motor Capacity</th> <th>75 kW</th> <th>90 kW</th> <th>110 kW</th> <th>132 kW</th> <th>160 kW</th> <th>185 kW</th> <th>220 kW</th> <th>280 kW</th> <th>375 kW</th> </tr> </thead> <tbody> <tr> <td rowspan="2">Inverter</td> <td>200V</td> <td>75K</td> <td>90K</td> <td>110K</td> <td>—</td> <td>—</td> <td>—</td> <td>—</td> <td>—</td> <td>—</td> </tr> <tr> <td>400V</td> <td>75K</td> <td>90K</td> <td>110K</td> <td>132K</td> <td>160K</td> <td>185K</td> <td>220K</td> <td>280K</td> <td>375K</td> </tr> <tr> <td rowspan="6">Brake unit</td> <td rowspan="2">200V</td> <td>MT-BU5-55K</td> <td>5</td> <td>—</td> <td>—</td> <td>—</td> <td>—</td> <td>—</td> <td>—</td> <td>—</td> </tr> <tr> <td>MT-BU5-110K</td> <td>20</td> <td>15</td> <td>10</td> <td>—</td> <td>—</td> <td>—</td> <td>—</td> <td>—</td> </tr> <tr> <td rowspan="4">400V</td> <td>MT-BU5-H75K</td> <td>10</td> <td>5</td> <td>—</td> <td>—</td> <td>—</td> <td>—</td> <td>—</td> <td>—</td> </tr> <tr> <td>MT-BU5-H150K</td> <td>40</td> <td>25</td> <td>20</td> <td>10</td> <td>5</td> <td>5</td> <td>—</td> <td>—</td> </tr> <tr> <td>MT-BU5-H220K</td> <td>80</td> <td>60</td> <td>40</td> <td>25</td> <td>15</td> <td>10</td> <td>10</td> <td>5</td> </tr> <tr> <td>MT-BU5-H280K</td> <td>—</td> <td>80</td> <td>65</td> <td>40</td> <td>30</td> <td>20</td> <td>15</td> <td>10</td> </tr> <tr> <td>MT-BU5-H375K</td> <td>—</td> <td>—</td> <td>—</td> <td>80</td> <td>50</td> <td>40</td> <td>20</td> <td>15</td> <td>10</td> </tr> </tbody> </table>	Motor Capacity		75 kW	90 kW	110 kW	132 kW	160 kW	185 kW	220 kW	280 kW	375 kW	Inverter	200V	75K	90K	110K	—	—	—	—	—	—	400V	75K	90K	110K	132K	160K	185K	220K	280K	375K	Brake unit	200V	MT-BU5-55K	5	—	—	—	—	—	—	—	MT-BU5-110K	20	15	10	—	—	—	—	—	400V	MT-BU5-H75K	10	5	—	—	—	—	—	—	MT-BU5-H150K	40	25	20	10	5	5	—	—	MT-BU5-H220K	80	60	40	25	15	10	10	5	MT-BU5-H280K	—	80	65	40	30	20	15	10	MT-BU5-H375K	—	—	—	80	50	40	20	15	10																						
	Motor Capacity		75 kW	90 kW	110 kW	132 kW	160 kW	185 kW	220 kW	280 kW	375 kW																																																																																																															
	Inverter	200V	75K	90K	110K	—	—	—	—	—	—																																																																																																															
		400V	75K	90K	110K	132K	160K	185K	220K	280K	375K																																																																																																															
	Brake unit	200V	MT-BU5-55K	5	—	—	—	—	—	—	—																																																																																																															
			MT-BU5-110K	20	15	10	—	—	—	—	—																																																																																																															
		400V	MT-BU5-H75K	10	5	—	—	—	—	—	—																																																																																																															
			MT-BU5-H150K	40	25	20	10	5	5	—	—																																																																																																															
MT-BU5-H220K			80	60	40	25	15	10	10	5																																																																																																																
MT-BU5-H280K			—	80	65	40	30	20	15	10																																																																																																																
MT-BU5-H375K	—	—	—	80	50	40	20	15	10																																																																																																																	
<ul style="list-style-type: none"> Brake unit and resistor unit combinations and cables 																																																																																																																										
<table border="1" style="width:100%; border-collapse: collapse; text-align: center;"> <thead> <tr> <th>Brake Unit Type</th> <th>Resistor Unit Type</th> <th>Cable</th> </tr> </thead> <tbody> <tr> <td rowspan="2">200V</td> <td>MT-BU5-55K</td> <td>MT-BR5-55K</td> <td>14mm²</td> </tr> <tr> <td>MT-BU5-110K</td> <td>2×MT-BR5-55K</td> <td>2×14mm²</td> </tr> <tr> <td rowspan="5">400V</td> <td>MT-BU5-H75K</td> <td>MT-BR5-H75K</td> <td>14mm²</td> </tr> <tr> <td>MT-BU5-H150K</td> <td>2×MT-BR5-H75K</td> <td>2×14mm²</td> </tr> <tr> <td>MT-BU5-H220K</td> <td>3×MT-BR5-H75K</td> <td>3×14mm²</td> </tr> <tr> <td>MT-BU5-H280K</td> <td>4×MT-BR5-H75K</td> <td>4×14mm²</td> </tr> <tr> <td>MT-BU5-H375K</td> <td>5×MT-BR5-H75K</td> <td>5×14mm²</td> </tr> </tbody> </table>	Brake Unit Type	Resistor Unit Type	Cable	200V	MT-BU5-55K	MT-BR5-55K	14mm ²	MT-BU5-110K	2×MT-BR5-55K	2×14mm ²	400V	MT-BU5-H75K	MT-BR5-H75K	14mm ²	MT-BU5-H150K	2×MT-BR5-H75K	2×14mm ²	MT-BU5-H220K	3×MT-BR5-H75K	3×14mm ²	MT-BU5-H280K	4×MT-BR5-H75K	4×14mm ²	MT-BU5-H375K	5×MT-BR5-H75K	5×14mm ²																																																																																																
Brake Unit Type	Resistor Unit Type	Cable																																																																																																																								
200V	MT-BU5-55K	MT-BR5-55K	14mm ²																																																																																																																							
	MT-BU5-110K	2×MT-BR5-55K	2×14mm ²																																																																																																																							
400V	MT-BU5-H75K	MT-BR5-H75K	14mm ²																																																																																																																							
	MT-BU5-H150K	2×MT-BR5-H75K	2×14mm ²																																																																																																																							
	MT-BU5-H220K	3×MT-BR5-H75K	3×14mm ²																																																																																																																							
	MT-BU5-H280K	4×MT-BR5-H75K	4×14mm ²																																																																																																																							
	MT-BU5-H375K	5×MT-BR5-H75K	5×14mm ²																																																																																																																							
<ul style="list-style-type: none"> Braking torque (%) at short-time rating when 100% ED is 15s 																																																																																																																										
<table border="1" style="width:100%; border-collapse: collapse; text-align: center;"> <thead> <tr> <th colspan="2">Motor Capacity</th> <th>75 kW</th> <th>90 kW</th> <th>110 kW</th> <th>132 kW</th> <th>160 kW</th> <th>185 kW</th> <th>220 kW</th> <th>280 kW</th> <th>375 kW</th> </tr> </thead> <tbody> <tr> <td rowspan="2">Inverter</td> <td>200V</td> <td>75K</td> <td>90K</td> <td>110K</td> <td>—</td> <td>—</td> <td>—</td> <td>—</td> <td>—</td> <td>—</td> </tr> <tr> <td>400V</td> <td>75K</td> <td>90K</td> <td>110K</td> <td>132K</td> <td>160K</td> <td>185K</td> <td>220K</td> <td>280K</td> <td>375K</td> </tr> <tr> <td rowspan="6">Brake unit</td> <td rowspan="2">200V</td> <td>MT-BU5-55K</td> <td>braking torque (%)</td> <td>70</td> <td>60</td> <td>50</td> <td>—</td> <td>—</td> <td>—</td> <td>—</td> </tr> <tr> <td>MT-BU5-110K</td> <td>150</td> <td>120</td> <td>100</td> <td>—</td> <td>—</td> <td>—</td> <td>—</td> <td>—</td> </tr> <tr> <td rowspan="4">400V</td> <td>MT-BU5-H75K</td> <td>100</td> <td>80</td> <td>70</td> <td>55</td> <td>45</td> <td>40</td> <td>35</td> <td>25</td> </tr> <tr> <td>MT-BU5-H150K</td> <td>150</td> <td>150</td> <td>135</td> <td>110</td> <td>90</td> <td>80</td> <td>70</td> <td>50</td> </tr> <tr> <td>MT-BU5-H220K</td> <td>150</td> <td>150</td> <td>150</td> <td>150</td> <td>135</td> <td>115</td> <td>100</td> <td>80</td> </tr> <tr> <td>MT-BU5-H280K</td> <td>150</td> <td>150</td> <td>150</td> <td>150</td> <td>150</td> <td>150</td> <td>125</td> <td>100</td> </tr> <tr> <td>MT-BU5-H375K</td> <td>150</td> <td>150</td> <td>150</td> <td>150</td> <td>150</td> <td>150</td> <td>150</td> <td>130</td> </tr> </tbody> </table>	Motor Capacity		75 kW	90 kW	110 kW	132 kW	160 kW	185 kW	220 kW	280 kW	375 kW	Inverter	200V	75K	90K	110K	—	—	—	—	—	—	400V	75K	90K	110K	132K	160K	185K	220K	280K	375K	Brake unit	200V	MT-BU5-55K	braking torque (%)	70	60	50	—	—	—	—	MT-BU5-110K	150	120	100	—	—	—	—	—	400V	MT-BU5-H75K	100	80	70	55	45	40	35	25	MT-BU5-H150K	150	150	135	110	90	80	70	50	MT-BU5-H220K	150	150	150	150	135	115	100	80	MT-BU5-H280K	150	150	150	150	150	150	125	100	MT-BU5-H375K	150	150	150	150	150	150	150	130																								
Motor Capacity		75 kW	90 kW	110 kW	132 kW	160 kW	185 kW	220 kW	280 kW	375 kW																																																																																																																
Inverter	200V	75K	90K	110K	—	—	—	—	—	—																																																																																																																
	400V	75K	90K	110K	132K	160K	185K	220K	280K	375K																																																																																																																
Brake unit	200V	MT-BU5-55K	braking torque (%)	70	60	50	—	—	—	—																																																																																																																
		MT-BU5-110K	150	120	100	—	—	—	—	—																																																																																																																
	400V	MT-BU5-H75K	100	80	70	55	45	40	35	25																																																																																																																
		MT-BU5-H150K	150	150	135	110	90	80	70	50																																																																																																																
		MT-BU5-H220K	150	150	150	150	135	115	100	80																																																																																																																
		MT-BU5-H280K	150	150	150	150	150	150	125	100																																																																																																																
MT-BU5-H375K	150	150	150	150	150	150	150	130																																																																																																																		
<p>* To obtain a large braking torque, the motor has to have a torque characteristic that meets the braking torque. Check the torque characteristic of the motor.</p>																																																																																																																										
<ul style="list-style-type: none"> Outline dimension drawings 																																																																																																																										
<table border="1" style="width:100%; border-collapse: collapse; text-align: center;"> <thead> <tr> <th>Brake Unit Type</th> <th>A</th> <th>AA</th> <th>AB</th> <th>B</th> <th>BA</th> <th>C</th> <th>Lc</th> <th>LP</th> <th>LN</th> <th>N</th> <th>Approx. mass</th> <th>X</th> <th>Y</th> <th>Z</th> </tr> </thead> <tbody> <tr> <td rowspan="2">200V class</td> <td>MT-BU5-55K</td> <td>118</td> <td>102</td> <td>90</td> <td>200</td> <td>100</td> <td>256.5</td> <td>550</td> <td>1740</td> <td>1740</td> <td>1</td> <td>1.5</td> <td>14</td> <td>12</td> <td>8</td> </tr> <tr> <td>MT-BU5-110K</td> <td>188</td> <td>172</td> <td>160</td> <td>200</td> <td>100</td> <td>256.5</td> <td>550</td> <td>2000</td> <td>2000</td> <td>2</td> <td>3.0</td> <td>22</td> <td>12</td> <td>8</td> </tr> <tr> <td rowspan="4">400V class</td> <td>MT-BU5-H75K</td> <td>118</td> <td>102</td> <td>90</td> <td>200</td> <td>100</td> <td>256.5</td> <td>550</td> <td>1740</td> <td>1740</td> <td>1</td> <td>1.5</td> <td>14</td> <td>12</td> <td>8</td> </tr> <tr> <td>MT-BU5-H150K</td> <td>188</td> <td>172</td> <td>160</td> <td>200</td> <td>100</td> <td>256.5</td> <td>550</td> <td>2000</td> <td>2000</td> <td>2</td> <td>3.0</td> <td>22</td> <td>12</td> <td>8</td> </tr> <tr> <td>MT-BU5-H220K</td> <td>258</td> <td>242</td> <td>230</td> <td>200</td> <td>100</td> <td>256.5</td> <td>550</td> <td>2000</td> <td>2000</td> <td>3</td> <td>4.5</td> <td>38</td> <td>12</td> <td>8</td> </tr> <tr> <td>MT-BU5-H280K</td> <td>328</td> <td>312</td> <td>300</td> <td>200</td> <td>100</td> <td>256.5</td> <td>550</td> <td>2330</td> <td>2330</td> <td>4</td> <td>6.0</td> <td>60</td> <td>12</td> <td>10</td> </tr> <tr> <td>MT-BU5-H375K</td> <td>398</td> <td>382</td> <td>370</td> <td>200</td> <td>100</td> <td>256.5</td> <td>550</td> <td>2330</td> <td>2330</td> <td>5</td> <td>7.5</td> <td>60</td> <td>12</td> <td>10</td> </tr> </tbody> </table>	Brake Unit Type	A	AA	AB	B	BA	C	Lc	LP	LN	N	Approx. mass	X	Y	Z	200V class	MT-BU5-55K	118	102	90	200	100	256.5	550	1740	1740	1	1.5	14	12	8	MT-BU5-110K	188	172	160	200	100	256.5	550	2000	2000	2	3.0	22	12	8	400V class	MT-BU5-H75K	118	102	90	200	100	256.5	550	1740	1740	1	1.5	14	12	8	MT-BU5-H150K	188	172	160	200	100	256.5	550	2000	2000	2	3.0	22	12	8	MT-BU5-H220K	258	242	230	200	100	256.5	550	2000	2000	3	4.5	38	12	8	MT-BU5-H280K	328	312	300	200	100	256.5	550	2330	2330	4	6.0	60	12	10	MT-BU5-H375K	398	382	370	200	100	256.5	550	2330	2330	5	7.5	60	12	10
Brake Unit Type	A	AA	AB	B	BA	C	Lc	LP	LN	N	Approx. mass	X	Y	Z																																																																																																												
200V class	MT-BU5-55K	118	102	90	200	100	256.5	550	1740	1740	1	1.5	14	12	8																																																																																																											
	MT-BU5-110K	188	172	160	200	100	256.5	550	2000	2000	2	3.0	22	12	8																																																																																																											
400V class	MT-BU5-H75K	118	102	90	200	100	256.5	550	1740	1740	1	1.5	14	12	8																																																																																																											
	MT-BU5-H150K	188	172	160	200	100	256.5	550	2000	2000	2	3.0	22	12	8																																																																																																											
	MT-BU5-H220K	258	242	230	200	100	256.5	550	2000	2000	3	4.5	38	12	8																																																																																																											
	MT-BU5-H280K	328	312	300	200	100	256.5	550	2330	2330	4	6.0	60	12	10																																																																																																											
MT-BU5-H375K	398	382	370	200	100	256.5	550	2330	2330	5	7.5	60	12	10																																																																																																												
<table border="1" style="width:100%; border-collapse: collapse; text-align: center;"> <thead> <tr> <th>Resistor Unit Type</th> <th>Resistance Value</th> <th>Mass</th> </tr> </thead> <tbody> <tr> <td>200V class MT-BR5-55K</td> <td>2.0Ω</td> <td>50kg</td> </tr> <tr> <td>400V class MT-BR5-H75K</td> <td>6.5Ω</td> <td>70kg</td> </tr> </tbody> </table>	Resistor Unit Type	Resistance Value	Mass	200V class MT-BR5-55K	2.0Ω	50kg	400V class MT-BR5-H75K	6.5Ω	70kg																																																																																																																	
Resistor Unit Type	Resistance Value	Mass																																																																																																																								
200V class MT-BR5-55K	2.0Ω	50kg																																																																																																																								
400V class MT-BR5-H75K	6.5Ω	70kg																																																																																																																								
<ul style="list-style-type: none"> External connection diagram 																																																																																																																										
<p>(Caution 1) For wiring of the brake unit and inverter, use an accessory cable supplied with the brake unit. Connect the main circuit cable to the terminals P/+ and N/- and connect the control circuit cable to the connector (CN8) inside by making cuts in the rubber bush at the top of the inverter.</p> <p>(Caution 2) The brake unit which uses multiple resistor units has terminals equal to the number of resistor units. Connect one resistor unit to one pair of terminals (P, PR).</p>																																																																																																																										
<div style="text-align: center;"> </div>																																																																																																																										
<p>*1 When the power supply is 400V class, install a step-down transformer. *2 The wiring length between the resistor unit and brake resistor should be 10m maximum when wires are twisted and 5m maximum when wires are not twisted.</p>																																																																																																																										

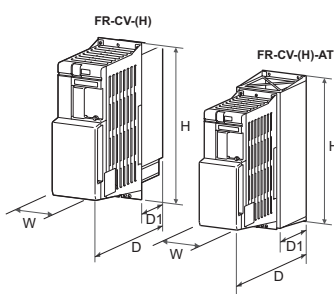
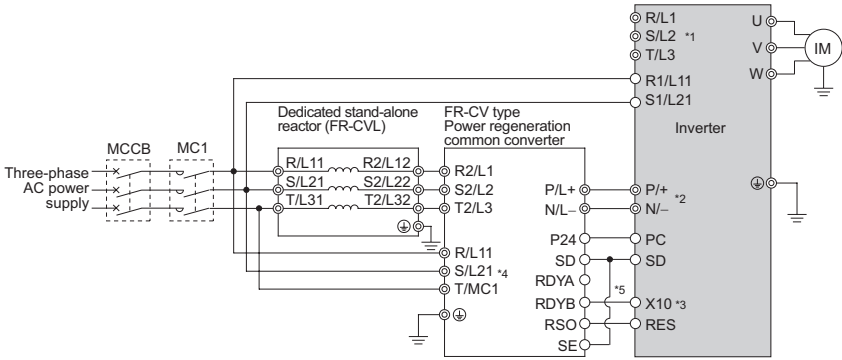
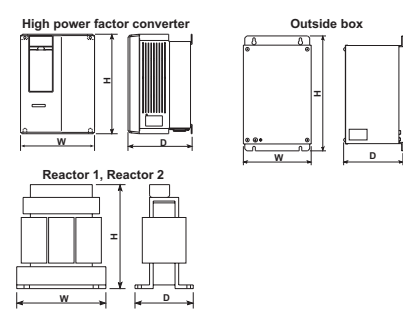
Name (type)	Specifications, Structure, etc.																																																																																																																																													
Power regeneration common converter FR-CV-(H)□□K	<ul style="list-style-type: none"> Enables 100%-torque continuous regeneration to support continuous regenerative operation for line control, etc. Eliminates the need to use a brake unit with each inverter, reducing total space and total cost. Saves energy since regeneration energy is used for the other inverters and excess energy is returned to the power supply. 																																																																																																																																													
	FR-CV-(H) (Unit mm) <table border="1" data-bbox="343 324 1029 481"> <thead> <tr> <th rowspan="2">Voltage/Capacity</th> <th colspan="4">200V</th> <th colspan="4">400V</th> </tr> <tr> <th>W</th> <th>D</th> <th>D1</th> <th>H</th> <th>W</th> <th>D</th> <th>D1</th> <th>H</th> </tr> </thead> <tbody> <tr> <td>7.5K/11K</td> <td>90</td> <td>303</td> <td>103</td> <td>300</td> <td>120</td> <td>305</td> <td>105</td> <td>300</td> </tr> <tr> <td>15K</td> <td>120</td> <td>305</td> <td>105</td> <td>300</td> <td>150</td> <td>305</td> <td>105</td> <td>380</td> </tr> <tr> <td>22K/30K</td> <td>150</td> <td>322</td> <td>122</td> <td>380</td> <td>400</td> <td>250</td> <td>135</td> <td>620</td> </tr> <tr> <td>37K/55K</td> <td>400</td> <td>250</td> <td>135</td> <td>620</td> <td></td> <td></td> <td></td> <td></td> </tr> </tbody> </table> 											Voltage/Capacity	200V				400V				W	D	D1	H	W	D	D1	H	7.5K/11K	90	303	103	300	120	305	105	300	15K	120	305	105	300	150	305	105	380	22K/30K	150	322	122	380	400	250	135	620	37K/55K	400	250	135	620																																																																																		
	Voltage/Capacity	200V				400V																																																																																																																																								
		W	D	D1	H	W	D	D1	H																																																																																																																																					
7.5K/11K	90	303	103	300	120	305	105	300																																																																																																																																						
15K	120	305	105	300	150	305	105	380																																																																																																																																						
22K/30K	150	322	122	380	400	250	135	620																																																																																																																																						
37K/55K	400	250	135	620																																																																																																																																										
FR-CV-(H)-AT (Unit mm) <table border="1" data-bbox="343 504 1029 638"> <thead> <tr> <th rowspan="2">Voltage/Capacity</th> <th colspan="4">200V</th> <th colspan="4">400V</th> </tr> <tr> <th>W</th> <th>D</th> <th>D1</th> <th>H</th> <th>W</th> <th>D</th> <th>D1</th> <th>H</th> </tr> </thead> <tbody> <tr> <td>7.5K/11K</td> <td>110</td> <td>315</td> <td>115</td> <td>330</td> <td>130</td> <td>320</td> <td>120</td> <td>330</td> </tr> <tr> <td>15K</td> <td>130</td> <td>320</td> <td>120</td> <td>330</td> <td>160</td> <td>350</td> <td>150</td> <td>410</td> </tr> <tr> <td>22K/30K</td> <td>160</td> <td>350</td> <td>150</td> <td>410</td> <td></td> <td></td> <td></td> <td></td> </tr> </tbody> </table>											Voltage/Capacity	200V				400V				W	D	D1	H	W	D	D1	H	7.5K/11K	110	315	115	330	130	320	120	330	15K	130	320	120	330	160	350	150	410	22K/30K	160	350	150	410																																																																																												
Voltage/Capacity	200V				400V																																																																																																																																									
	W	D	D1	H	W	D	D1	H																																																																																																																																						
7.5K/11K	110	315	115	330	130	320	120	330																																																																																																																																						
15K	130	320	120	330	160	350	150	410																																																																																																																																						
22K/30K	160	350	150	410																																																																																																																																										
<ul style="list-style-type: none"> Connection example  <p>*1. Remove the jumpers across terminals R/L1-R1/L11 and S/L2-S1/L21 of the inverter, and connect the control circuit power supply across terminals R1/L11-S1/L21. Always keep the power input terminals R/L1, S/L2, T/L3 open. Incorrect connection will damage the inverter. Opposite polarity of terminals N/-, P/+ will damage the inverter.</p> <p>*2. Do not insert an MCCB between the terminals P/+N/- (between P/L+-P/+), between N/L-N/-). Do not remove a jumper across terminal P/+ and P1 except when connecting a DC reactor.</p> <p>*3. Assign the terminal for X10 signal using any of Pr. 178 to Pr. 189 (input terminal function selection).</p> <p>*4. Always connect the power supply and terminals R/L11, S/L21, T/MC1. If the inverter is operated without connection, the power regeneration common converter will be damaged.</p>																																																																																																																																														
High power factor converter FR-HC-(H)□□K	<ul style="list-style-type: none"> Substantially suppresses power harmonics to realize the equivalent capacity conversion coefficient K5=0 in the Japanese "Harmonic suppression guideline for consumers who receive high voltage or special high voltage". Has the power regeneration function as standard. Connects multiple inverters to enable common converter system operation. 																																																																																																																																													
	<ul style="list-style-type: none"> Specifications 																																																																																																																																													
	<table border="1" data-bbox="343 1359 1428 1545"> <thead> <tr> <th rowspan="2">Type FR-HC□□</th> <th colspan="4">200V</th> <th colspan="4">400V</th> </tr> <tr> <th>7.5K</th> <th>15K</th> <th>30K</th> <th>55K</th> <th>H7.5K</th> <th>H15K</th> <th>H30K</th> <th>H55K</th> </tr> </thead> <tbody> <tr> <td>Applicable inverter capacity *1</td> <td>3.7K to 7.5K</td> <td>7.5K to 15K</td> <td>15K to 30K</td> <td>30K to 55K</td> <td>3.7K to 7.5K</td> <td>7.5K to 15K</td> <td>15K to 30K</td> <td>30K to 55K</td> </tr> <tr> <td>Rated input voltage/frequency</td> <td colspan="4">Three-phase 200V to 220V 50Hz 200V to 230V 60Hz</td> <td colspan="4">Three-phase 380V to 460V 50/60Hz</td> </tr> <tr> <td>Rated input current (A)</td> <td>33</td> <td>61</td> <td>115</td> <td>215</td> <td>17</td> <td>31</td> <td>57</td> <td>110</td> </tr> <tr> <td>Rated output voltage (V) *2</td> <td colspan="4">293V to 335VDC</td> <td colspan="4">558V to 670VDC</td> </tr> </tbody> </table> <p>*1. The applicable capacity to the high power factor converter is the total capacity of the inverters. *2. The output voltage varies with the input voltage value.</p>											Type FR-HC□□	200V				400V				7.5K	15K	30K	55K	H7.5K	H15K	H30K	H55K	Applicable inverter capacity *1	3.7K to 7.5K	7.5K to 15K	15K to 30K	30K to 55K	3.7K to 7.5K	7.5K to 15K	15K to 30K	30K to 55K	Rated input voltage/frequency	Three-phase 200V to 220V 50Hz 200V to 230V 60Hz				Three-phase 380V to 460V 50/60Hz				Rated input current (A)	33	61	115	215	17	31	57	110	Rated output voltage (V) *2	293V to 335VDC				558V to 670VDC																																																																																	
Type FR-HC□□	200V				400V																																																																																																																																									
	7.5K	15K	30K	55K	H7.5K	H15K	H30K	H55K																																																																																																																																						
Applicable inverter capacity *1	3.7K to 7.5K	7.5K to 15K	15K to 30K	30K to 55K	3.7K to 7.5K	7.5K to 15K	15K to 30K	30K to 55K																																																																																																																																						
Rated input voltage/frequency	Three-phase 200V to 220V 50Hz 200V to 230V 60Hz				Three-phase 380V to 460V 50/60Hz																																																																																																																																									
Rated input current (A)	33	61	115	215	17	31	57	110																																																																																																																																						
Rated output voltage (V) *2	293V to 335VDC				558V to 670VDC																																																																																																																																									
<ul style="list-style-type: none"> Outline dimension 																																																																																																																																														
<table border="1" data-bbox="343 1662 997 1993"> <thead> <tr> <th rowspan="2">Voltage</th> <th rowspan="2">Capacity</th> <th colspan="3">High power factor converter FR-HC</th> <th colspan="3">Reactor 1 FR-HCL01</th> <th colspan="3">Reactor 2 FR-HCL02</th> <th colspan="3">Outside box FR-HCB</th> </tr> <tr> <th>W</th> <th>H</th> <th>D</th> <th>W</th> <th>H</th> <th>D</th> <th>W</th> <th>H</th> <th>D</th> <th>W</th> <th>H</th> <th>D</th> </tr> </thead> <tbody> <tr> <td rowspan="4">200V</td> <td>7.5K</td> <td>220</td> <td>300</td> <td>190</td> <td>160</td> <td>155</td> <td>100</td> <td>240</td> <td>230</td> <td>160</td> <td>190</td> <td>320</td> <td>165</td> </tr> <tr> <td>15K</td> <td>250</td> <td>400</td> <td>190</td> <td>190</td> <td>205</td> <td>130</td> <td>260</td> <td>270</td> <td>170</td> <td></td> <td></td> <td></td> </tr> <tr> <td>30K</td> <td>340</td> <td>550</td> <td>195</td> <td>220</td> <td>230</td> <td>170</td> <td>340</td> <td>320</td> <td>180</td> <td>270</td> <td>450</td> <td>203</td> </tr> <tr> <td>55K</td> <td>480</td> <td>700</td> <td>250</td> <td>210</td> <td>260</td> <td>225</td> <td>430</td> <td>470</td> <td>360</td> <td></td> <td></td> <td></td> </tr> <tr> <td rowspan="4">400V</td> <td>H7.5K</td> <td>220</td> <td>300</td> <td>190</td> <td>160</td> <td>150</td> <td>100</td> <td>240</td> <td>220</td> <td>160</td> <td>190</td> <td>320</td> <td>165</td> </tr> <tr> <td>H15K</td> <td>250</td> <td>400</td> <td>190</td> <td>190</td> <td>195</td> <td>130</td> <td>260</td> <td>260</td> <td>170</td> <td></td> <td></td> <td></td> </tr> <tr> <td>H30K</td> <td>340</td> <td>550</td> <td>195</td> <td>220</td> <td>215</td> <td>140</td> <td>340</td> <td>310</td> <td>180</td> <td>270</td> <td>450</td> <td>203</td> </tr> <tr> <td>H55K</td> <td>480</td> <td>700</td> <td>250</td> <td>280</td> <td>255</td> <td>190</td> <td>400</td> <td>380</td> <td>285</td> <td></td> <td></td> <td></td> </tr> </tbody> </table> 											Voltage	Capacity	High power factor converter FR-HC			Reactor 1 FR-HCL01			Reactor 2 FR-HCL02			Outside box FR-HCB			W	H	D	W	H	D	W	H	D	W	H	D	200V	7.5K	220	300	190	160	155	100	240	230	160	190	320	165	15K	250	400	190	190	205	130	260	270	170				30K	340	550	195	220	230	170	340	320	180	270	450	203	55K	480	700	250	210	260	225	430	470	360				400V	H7.5K	220	300	190	160	150	100	240	220	160	190	320	165	H15K	250	400	190	190	195	130	260	260	170				H30K	340	550	195	220	215	140	340	310	180	270	450	203	H55K	480	700	250	280	255	190	400	380	285			
Voltage	Capacity	High power factor converter FR-HC			Reactor 1 FR-HCL01			Reactor 2 FR-HCL02					Outside box FR-HCB																																																																																																																																	
		W	H	D	W	H	D	W	H	D	W	H	D																																																																																																																																	
200V	7.5K	220	300	190	160	155	100	240	230	160	190	320	165																																																																																																																																	
	15K	250	400	190	190	205	130	260	270	170																																																																																																																																				
	30K	340	550	195	220	230	170	340	320	180	270	450	203																																																																																																																																	
	55K	480	700	250	210	260	225	430	470	360																																																																																																																																				
400V	H7.5K	220	300	190	160	150	100	240	220	160	190	320	165																																																																																																																																	
	H15K	250	400	190	190	195	130	260	260	170																																																																																																																																				
	H30K	340	550	195	220	215	140	340	310	180	270	450	203																																																																																																																																	
	H55K	480	700	250	280	255	190	400	380	285																																																																																																																																				

- Features
- Peripheral Devices
- Standard Specifications
- Outline Dimension Drawings
- Terminal Connection Diagram Terminal Specification Explanation
- Operation Panel
- Parameter List
- Explanations of Parameters
- Protective Functions
- Options
- Instructions
- Motor
- Compatibility
- Warranty
- Inquiry

Name (type)	Specifications, Structure, etc.																																																																																																																																																																																																							
<p>● Application of the sine wave filter</p> <p>For the FR-A700 series (75K or more) inverter, the motor voltage and current can be made to nearly sine wave shaped by providing a sine wave filter on the output side.</p> <ol style="list-style-type: none"> 1) Low noise 2) Surgeless 3) Motor loss reduction (use of standard motor) <p>● Application condition</p> <p>The following conditions have to be satisfied to install the sine wave filter.</p> <ol style="list-style-type: none"> 1) Change the Pr: 72 setting to "25". (The initial value is "2".) <p>The carrier frequency changes to 2.5KHz. (The sine wave filter is designed on condition that the carrier frequency is 2.5KHz. Be sure to change the setting properly.) If the inverter is operated with Pr.72 set to other than "25", the inverter and sine wave filter may be damaged.</p> <ol style="list-style-type: none"> 2) The sine wave filter can be used only for 60 Hz or less inverter frequency. <p>Note that the filter can not be used for the higher frequency operation than this. (Otherwise the filter loss will increase.)</p> <ol style="list-style-type: none"> 3) Use the inverter with capacity one rank higher. *2 4) Install an external thermal relay of the motor. 5) This function is valid for V/F control only. (When 25 is set in Pr.72, V/F control is automatically selected. 6) Use the MT-BSL-HC when using a sine wave filter with the MT-HC. <p>● Circuit configuration and connection</p>	<p>Motor Capacity (kW)</p> <table border="1"> <thead> <tr> <th rowspan="2">Motor Capacity (kW)</th> <th colspan="2">Inverter Type</th> <th rowspan="2">Applied Inverter (*2)</th> </tr> <tr> <th>Reactor for filter</th> <th>Capacitor for filter</th> </tr> </thead> <tbody> <tr> <td rowspan="2">200V class</td> <td>75</td> <td>MT-BSL-75K</td> <td>1×MT-BSC-75K</td> <td>FR-A720-90K</td> </tr> <tr> <td>90</td> <td>MT-BSL-90K</td> <td>1×MT-BSC-90K</td> <td>—</td> </tr> <tr> <td rowspan="8">400V class</td> <td>75</td> <td>MT-BSL-H75K(-HC)</td> <td>1×MT-BSC-H75K</td> <td>FR-A740-90K</td> </tr> <tr> <td>90</td> <td>MT-BSL-H110K(-HC)</td> <td>1×MT-BSC-H110K</td> <td>FR-A740-110K</td> </tr> <tr> <td>110</td> <td>MT-BSL-H110K(-HC)</td> <td>1×MT-BSC-H110K</td> <td>FR-A740-132K</td> </tr> <tr> <td>132</td> <td>MT-BSL-H150K(-HC)</td> <td>2×MT-BSC-H75K</td> <td>FR-A740-160K</td> </tr> <tr> <td>160</td> <td>MT-BSL-H220K(-HC)</td> <td>2×MT-BSC-H110K</td> <td>FR-A740-185K</td> </tr> <tr> <td>185</td> <td>MT-BSL-H220K(-HC)</td> <td>2×MT-BSC-H110K</td> <td>FR-A740-220K</td> </tr> <tr> <td>220</td> <td>MT-BSL-H220K(-HC)</td> <td>2×MT-BSC-H110K</td> <td>FR-A740-250K</td> </tr> <tr> <td>250</td> <td>MT-BSL-H280K(-HC)</td> <td>3×MT-BSC-H110K</td> <td>FR-A740-280K</td> </tr> <tr> <td>280</td> <td>MT-BSL-H280K(-HC)</td> <td>3×MT-BSC-H110K</td> <td>FR-A740-315K</td> </tr> </tbody> </table> <p>*1 For the 2 ×, connect capacitors in parallel as in the connection diagram. *2 If the rated motor current × (1.05 to 1.1) is less than 90% of the inverter rated current, an inverter with same kW with a motor can be used.</p>	Motor Capacity (kW)	Inverter Type		Applied Inverter (*2)	Reactor for filter	Capacitor for filter	200V class	75	MT-BSL-75K	1×MT-BSC-75K	FR-A720-90K	90	MT-BSL-90K	1×MT-BSC-90K	—	400V class	75	MT-BSL-H75K(-HC)	1×MT-BSC-H75K	FR-A740-90K	90	MT-BSL-H110K(-HC)	1×MT-BSC-H110K	FR-A740-110K	110	MT-BSL-H110K(-HC)	1×MT-BSC-H110K	FR-A740-132K	132	MT-BSL-H150K(-HC)	2×MT-BSC-H75K	FR-A740-160K	160	MT-BSL-H220K(-HC)	2×MT-BSC-H110K	FR-A740-185K	185	MT-BSL-H220K(-HC)	2×MT-BSC-H110K	FR-A740-220K	220	MT-BSL-H220K(-HC)	2×MT-BSC-H110K	FR-A740-250K	250	MT-BSL-H280K(-HC)	3×MT-BSC-H110K	FR-A740-280K	280	MT-BSL-H280K(-HC)	3×MT-BSC-H110K	FR-A740-315K																																																																																																																																																			
Motor Capacity (kW)	Inverter Type		Applied Inverter (*2)																																																																																																																																																																																																					
	Reactor for filter	Capacitor for filter																																																																																																																																																																																																						
200V class	75	MT-BSL-75K	1×MT-BSC-75K	FR-A720-90K																																																																																																																																																																																																				
	90	MT-BSL-90K	1×MT-BSC-90K	—																																																																																																																																																																																																				
400V class	75	MT-BSL-H75K(-HC)	1×MT-BSC-H75K	FR-A740-90K																																																																																																																																																																																																				
	90	MT-BSL-H110K(-HC)	1×MT-BSC-H110K	FR-A740-110K																																																																																																																																																																																																				
	110	MT-BSL-H110K(-HC)	1×MT-BSC-H110K	FR-A740-132K																																																																																																																																																																																																				
	132	MT-BSL-H150K(-HC)	2×MT-BSC-H75K	FR-A740-160K																																																																																																																																																																																																				
	160	MT-BSL-H220K(-HC)	2×MT-BSC-H110K	FR-A740-185K																																																																																																																																																																																																				
	185	MT-BSL-H220K(-HC)	2×MT-BSC-H110K	FR-A740-220K																																																																																																																																																																																																				
	220	MT-BSL-H220K(-HC)	2×MT-BSC-H110K	FR-A740-250K																																																																																																																																																																																																				
	250	MT-BSL-H280K(-HC)	3×MT-BSC-H110K	FR-A740-280K																																																																																																																																																																																																				
280	MT-BSL-H280K(-HC)	3×MT-BSC-H110K	FR-A740-315K																																																																																																																																																																																																					
<p>Sine wave filter MT-BSL-(H)□□K MT-BSC-(H)□□K</p>	<p>● Reactor for sine wave filter</p> <p>● Capacitor for sine wave filter</p>																																																																																																																																																																																																							
	<table border="1"> <thead> <tr> <th colspan="2">Inverter type</th> <th>A</th> <th>B</th> <th>C</th> <th>D</th> <th>E</th> <th>F</th> <th>G</th> <th>H</th> <th>Mass (kg)</th> </tr> </thead> <tbody> <tr> <td rowspan="2">200V class</td> <td>MT-BSL-75K</td> <td>330</td> <td>150</td> <td>285</td> <td>185</td> <td>216</td> <td>328</td> <td>M10</td> <td>M12</td> <td>80</td> </tr> <tr> <td>MT-BSL-90K</td> <td>390</td> <td>150</td> <td>320</td> <td>180</td> <td>220</td> <td>330</td> <td>M12</td> <td>M12</td> <td>120</td> </tr> <tr> <td rowspan="8">400V class</td> <td>MT-BSL-H75K</td> <td>330</td> <td>150</td> <td>285</td> <td>185</td> <td>216</td> <td>318</td> <td>M10</td> <td>M10</td> <td>80</td> </tr> <tr> <td>MT-BSL-H110K</td> <td>390</td> <td>150</td> <td>340</td> <td>195</td> <td>235</td> <td>368</td> <td>M12</td> <td>M12</td> <td>140</td> </tr> <tr> <td>MT-BSL-H150K</td> <td>455</td> <td>200</td> <td>397</td> <td>200</td> <td>240</td> <td>380</td> <td>M12</td> <td>M12</td> <td>190</td> </tr> <tr> <td>MT-BSL-H220K</td> <td>495</td> <td>200</td> <td>405</td> <td>250</td> <td>300</td> <td>420</td> <td>M12</td> <td>M12</td> <td>240</td> </tr> <tr> <td>MT-BSL-H280K</td> <td>575</td> <td>200</td> <td>470</td> <td>310</td> <td>370</td> <td>485</td> <td>M12</td> <td>M12</td> <td>340</td> </tr> <tr> <td>MT-BSL-H75K-HC</td> <td>385</td> <td>150</td> <td>345</td> <td>185</td> <td>216</td> <td>315</td> <td>M10</td> <td>M10</td> <td>110</td> </tr> <tr> <td>MT-BSL-H110K-HC</td> <td>420</td> <td>170</td> <td>400</td> <td>195</td> <td>235</td> <td>370</td> <td>M12</td> <td>M12</td> <td>180</td> </tr> <tr> <td>MT-BSL-H150K-HC</td> <td>450</td> <td>300</td> <td>455</td> <td>390</td> <td>430</td> <td>500</td> <td>M12</td> <td>M12</td> <td>250</td> </tr> <tr> <td>MT-BSL-H220K-HC</td> <td>510</td> <td>350</td> <td>540</td> <td>430</td> <td>485</td> <td>555</td> <td>M12</td> <td>M12</td> <td>310</td> </tr> <tr> <td>MT-BSL-H280K-HC</td> <td>570</td> <td>400</td> <td>590</td> <td>475</td> <td>535</td> <td>620</td> <td>M12</td> <td>M12</td> <td>480</td> </tr> </tbody> </table> <table border="1"> <thead> <tr> <th colspan="2">Inverter type</th> <th>A</th> <th>B</th> <th>C</th> <th>D</th> <th>E</th> <th>F</th> <th>G</th> <th>H</th> <th>I</th> <th>Mass (kg)</th> </tr> </thead> <tbody> <tr> <td rowspan="2">200V class</td> <td>MT-BSC-75K</td> <td>207</td> <td>191</td> <td>285</td> <td>233</td> <td>72</td> <td>41</td> <td>45</td> <td>φ7</td> <td>M8</td> <td>3.9</td> </tr> <tr> <td>MT-BSC-90K</td> <td>282</td> <td>266</td> <td>270</td> <td>183</td> <td>92</td> <td>56</td> <td>85</td> <td>φ7</td> <td>M12</td> <td>5.5</td> </tr> <tr> <td rowspan="2">400V class</td> <td>MT-BSC-H75K</td> <td>207</td> <td>191</td> <td>220</td> <td>173</td> <td>72</td> <td>41</td> <td>55</td> <td>φ7</td> <td>M6</td> <td>3.0</td> </tr> <tr> <td>MT-BSC-H110K</td> <td>207</td> <td>191</td> <td>280</td> <td>233</td> <td>72</td> <td>41</td> <td>55</td> <td>φ7</td> <td>M6</td> <td>4.0</td> </tr> </tbody> </table> <p>* Leave more than 25mm space between capacitors.</p> <p>Recommended cable size</p> <p>The cable sizes between the Inverter and MT-BSL and between the MT-BSL and IM depend on U, V, W of "Peripheral devices list" (page 87)</p> <p>The cable size to the MT-BSC is as table below.</p> <table border="1"> <thead> <tr> <th>MT-BSC-75K</th> <th>MT-BSC-90K</th> <th>MT-BSC-H75K</th> <th>MT-BSC-H110K</th> </tr> </thead> <tbody> <tr> <td>38mm²</td> <td>38mm²</td> <td>22mm²</td> <td>22mm²</td> </tr> </tbody> </table>	Inverter type		A	B	C	D	E	F	G	H	Mass (kg)	200V class	MT-BSL-75K	330	150	285	185	216	328	M10	M12	80	MT-BSL-90K	390	150	320	180	220	330	M12	M12	120	400V class	MT-BSL-H75K	330	150	285	185	216	318	M10	M10	80	MT-BSL-H110K	390	150	340	195	235	368	M12	M12	140	MT-BSL-H150K	455	200	397	200	240	380	M12	M12	190	MT-BSL-H220K	495	200	405	250	300	420	M12	M12	240	MT-BSL-H280K	575	200	470	310	370	485	M12	M12	340	MT-BSL-H75K-HC	385	150	345	185	216	315	M10	M10	110	MT-BSL-H110K-HC	420	170	400	195	235	370	M12	M12	180	MT-BSL-H150K-HC	450	300	455	390	430	500	M12	M12	250	MT-BSL-H220K-HC	510	350	540	430	485	555	M12	M12	310	MT-BSL-H280K-HC	570	400	590	475	535	620	M12	M12	480	Inverter type		A	B	C	D	E	F	G	H	I	Mass (kg)	200V class	MT-BSC-75K	207	191	285	233	72	41	45	φ7	M8	3.9	MT-BSC-90K	282	266	270	183	92	56	85	φ7	M12	5.5	400V class	MT-BSC-H75K	207	191	220	173	72	41	55	φ7	M6	3.0	MT-BSC-H110K	207	191	280	233	72	41	55	φ7	M6	4.0	MT-BSC-75K	MT-BSC-90K	MT-BSC-H75K	MT-BSC-H110K	38mm ²	38mm ²	22mm ²	22mm ²
Inverter type		A	B	C	D	E	F	G	H	Mass (kg)																																																																																																																																																																																														
200V class	MT-BSL-75K	330	150	285	185	216	328	M10	M12	80																																																																																																																																																																																														
	MT-BSL-90K	390	150	320	180	220	330	M12	M12	120																																																																																																																																																																																														
400V class	MT-BSL-H75K	330	150	285	185	216	318	M10	M10	80																																																																																																																																																																																														
	MT-BSL-H110K	390	150	340	195	235	368	M12	M12	140																																																																																																																																																																																														
	MT-BSL-H150K	455	200	397	200	240	380	M12	M12	190																																																																																																																																																																																														
	MT-BSL-H220K	495	200	405	250	300	420	M12	M12	240																																																																																																																																																																																														
	MT-BSL-H280K	575	200	470	310	370	485	M12	M12	340																																																																																																																																																																																														
	MT-BSL-H75K-HC	385	150	345	185	216	315	M10	M10	110																																																																																																																																																																																														
	MT-BSL-H110K-HC	420	170	400	195	235	370	M12	M12	180																																																																																																																																																																																														
	MT-BSL-H150K-HC	450	300	455	390	430	500	M12	M12	250																																																																																																																																																																																														
MT-BSL-H220K-HC	510	350	540	430	485	555	M12	M12	310																																																																																																																																																																																															
MT-BSL-H280K-HC	570	400	590	475	535	620	M12	M12	480																																																																																																																																																																																															
Inverter type		A	B	C	D	E	F	G	H	I	Mass (kg)																																																																																																																																																																																													
200V class	MT-BSC-75K	207	191	285	233	72	41	45	φ7	M8	3.9																																																																																																																																																																																													
	MT-BSC-90K	282	266	270	183	92	56	85	φ7	M12	5.5																																																																																																																																																																																													
400V class	MT-BSC-H75K	207	191	220	173	72	41	55	φ7	M6	3.0																																																																																																																																																																																													
	MT-BSC-H110K	207	191	280	233	72	41	55	φ7	M6	4.0																																																																																																																																																																																													
MT-BSC-75K	MT-BSC-90K	MT-BSC-H75K	MT-BSC-H110K																																																																																																																																																																																																					
38mm ²	38mm ²	22mm ²	22mm ²																																																																																																																																																																																																					

Dedicated cable option

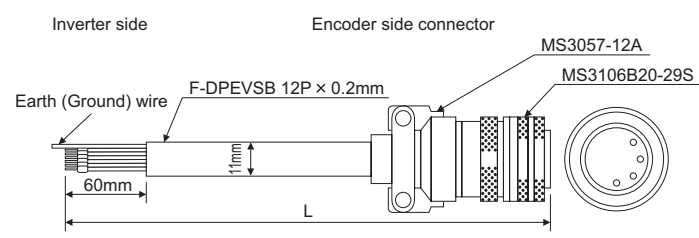
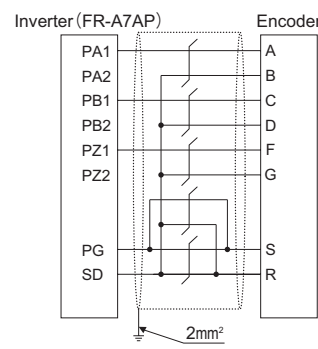
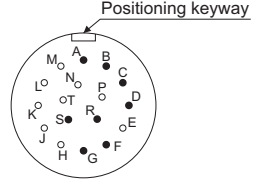
Name (type)	Specifications, Structure, etc.																										
Cable for encoder FR-V7CBL□□	<p>●For dedicated motor</p>  <p>Inverter side Encoder side connector MS3057-12A MS3106B20-29S Earth (Ground) wire F-DPEVSB 12P × 0.2mm L</p>  <p>Inverter (FR-A7AP) Encoder PA1 PA2 PB1 PB2 PZ1 PZ2 PG SD A B C D F G S R 2mm²</p>  <p>Positioning keyway MS3106B20-29S (As viewed from wiring side)</p> <table border="1" data-bbox="981 828 1236 929"> <thead> <tr> <th>Type</th> <th>Length L (m)</th> </tr> </thead> <tbody> <tr> <td>FR-V7CBL5</td> <td>5</td> </tr> <tr> <td>FR-V7CBL15</td> <td>15</td> </tr> <tr> <td>FR-V7CBL30</td> <td>30</td> </tr> </tbody> </table> <p>(Note) When a cable of 30m length or more is required, consult our sales office.</p>	Type	Length L (m)	FR-V7CBL5	5	FR-V7CBL15	15	FR-V7CBL30	30																		
	Type	Length L (m)																									
FR-V7CBL5	5																										
FR-V7CBL15	15																										
FR-V7CBL30	30																										
<p>●Cable selection specifications</p> <table border="1" data-bbox="383 1019 1141 1220"> <thead> <tr> <th rowspan="2">Wiring Distance</th> <th rowspan="2">Optional Encoder Dedicated Cable</th> <th colspan="2">Cable Specification</th> </tr> <tr> <th>Wiring 0.2mm² cables</th> <th>Using larger gauge cable</th> </tr> </thead> <tbody> <tr> <td>5m or less</td> <td>FR-V7CBL5</td> <td>2 parallels or more</td> <td rowspan="2">0.4mm² or more</td> </tr> <tr> <td>10m or less</td> <td rowspan="2">FR-V7CBL15</td> <td>2 parallels or more</td> </tr> <tr> <td>15m or less</td> <td>4 parallels or more</td> <td rowspan="2">0.75mm² or more</td> </tr> <tr> <td>20m or less</td> <td rowspan="2">FR-V7CBL30</td> <td>4 parallels or more</td> </tr> <tr> <td>30m or less</td> <td>6 parallels or more</td> <td rowspan="3">1.25mm² or more</td> </tr> <tr> <td>50m or less</td> <td rowspan="2">*Available on request, please consult us.</td> <td>6 parallels or more</td> </tr> <tr> <td>100m or less</td> <td>6 parallels or more</td> </tr> </tbody> </table> <p>If connection cables are not available, make cables according to the left table. Cables to terminals PG and SD should be connected in parallel or be larger in size.</p>	Wiring Distance	Optional Encoder Dedicated Cable	Cable Specification		Wiring 0.2mm ² cables	Using larger gauge cable	5m or less	FR-V7CBL5	2 parallels or more	0.4mm ² or more	10m or less	FR-V7CBL15	2 parallels or more	15m or less	4 parallels or more	0.75mm ² or more	20m or less	FR-V7CBL30	4 parallels or more	30m or less	6 parallels or more	1.25mm ² or more	50m or less	*Available on request, please consult us.	6 parallels or more	100m or less	6 parallels or more
Wiring Distance			Optional Encoder Dedicated Cable	Cable Specification																							
	Wiring 0.2mm ² cables	Using larger gauge cable																									
5m or less	FR-V7CBL5	2 parallels or more	0.4mm ² or more																								
10m or less	FR-V7CBL15	2 parallels or more																									
15m or less		4 parallels or more	0.75mm ² or more																								
20m or less	FR-V7CBL30	4 parallels or more																									
30m or less		6 parallels or more	1.25mm ² or more																								
50m or less	*Available on request, please consult us.	6 parallels or more																									
100m or less		6 parallels or more																									

Encoder connector (Manufactured by Japan Aviation Electronics Industries) for reference

(Unit: mm)

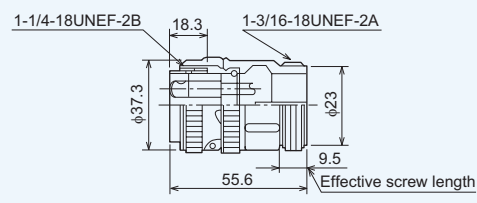
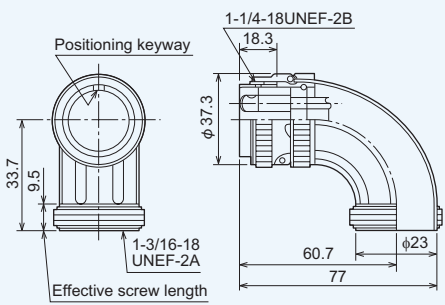
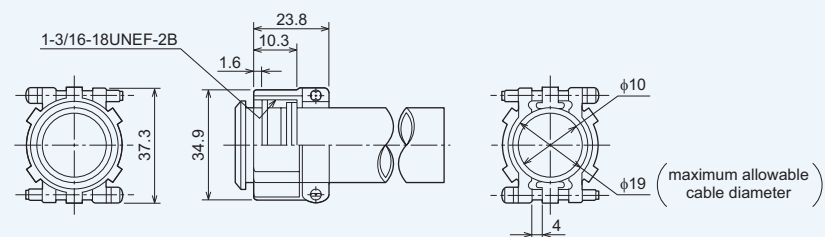
Straight Plug MS3106B20-29S	Angle Plug MS3108B20-29S
	 <p>(Note) This angle type connector is not optional. Please obtain it separately.</p>
Cable Clamp MS3057-12A	
	

- Features
- Peripheral Devices
- Standard Specifications
- Outline Dimension Drawings
- Terminal Connection Diagram Terminal Specification Explanation
- Operation Panel
- Parameter List
- Explanations of Parameters
- Protective Functions
- Options
- Instructions
- Motor
- Compatibility
- Warranty
- Inquiry

Peripheral devices/cable size list

Voltage	Motor Output (kW) ^{*1}	Applicable Inverter Type	Moulded Case Circuit Breaker (MCCB)*2 or Earth Leakage Current Breaker (ELB)		Input Side Magnetic Contactor*3		Recommended Cable Size (mm ²)*4	
			Reactor connection		Reactor connection		R, S, T	U, V, W
			Without	With	Without	With		
200V class	0.4	FR-A720-0.4K	30AF 5A	30AF 5A	S-N10	S-N10	2	2
	0.75	FR-A720-0.75K	30AF 10A	30AF 10A	S-N10	S-N10	2	2
	1.5	FR-A720-1.5K	30AF 15A	30AF 15A	S-N10	S-N10	2	2
	2.2	FR-A720-2.2K	30AF 20A	30AF 15A	S-N10	S-N10	2	2
	3.7	FR-A720-3.7K	30AF 30A	30AF 30A	S-N20, N21	S-N10	3.5	3.5
	5.5	FR-A720-5.5K	50AF 50A	50AF 40A	S-N25	S-N20, N21	5.5	5.5
	7.5	FR-A720-7.5K	100AF 60A	50AF 50A	S-N25	S-N25	14	8
	11	FR-A720-11K	100AF 75A	100AF 75A	S-N35	S-N35	14	14
	15	FR-A720-15K	225AF 125A	100AF 100A	S-N50	S-N50	22	22
	18.5	FR-A720-18.5K	225AF 150A	225AF 125A	S-N65	S-N50	38	38
	22	FR-A720-22K	225AF 175A	225AF 150A	S-N80	S-N65	38	38
	30	FR-A720-30K	225AF 225A	225AF 175A	S-N95	S-N80	60	60
	37	FR-A720-37K	400AF 250A	225AF 225A	S-N150	S-N125	80	80
	45	FR-A720-45K	400AF 300A	400AF 300A	S-N180	S-N150	100	100
	55	FR-A720-55K	400AF 400A	400AF 350A	S-N220	S-N180	100	100
75	FR-A720-75K	—	NV400AF400A	—	S-N300	125	125	
90	FR-A720-90K	—	NV400AF400A	—	S-N300	150	150	
400V class	0.4	FR-A740-0.4K	30AF 5A	30AF 5A	S-N10	S-N10	2	2
	0.75	FR-A740-0.75K	30AF 5A	30AF 5A	S-N10	S-N10	2	2
	1.5	FR-A740-1.5K	30AF 10A	30AF 10A	S-N10	S-N10	2	2
	2.2	FR-A740-2.2K	30AF 10A	30AF 10A	S-N10	S-N10	2	2
	3.7	FR-A740-3.7K	30AF 20A	30AF 15A	S-N10	S-N10	2	2
	5.5	FR-A740-5.5K	30AF 30A	30AF 20A	S-N20, N21	S-N11, N12	2	2
	7.5	FR-A740-7.5K	30AF 30A	30AF 30A	S-N20, N21	S-N20, N21	3.5	3.5
	11	FR-A740-11K	50AF 50A	50AF 40A	S-N20, N21	S-N20, N21	5.5	5.5
	15	FR-A740-15K	100AF 60A	50AF 50A	S-N25	S-N20, N21	8	8
	18.5	FR-A740-18.5K	100AF 75A	100AF 60A	S-N25	S-N25	14	8
	22	FR-A740-22K	100AF 100A	100AF 75A	S-N35	S-N25	14	14
	30	FR-A740-30K	225AF 125A	100AF 100A	S-N50	S-N50	22	22
	37	FR-A740-37K	225AF 150A	225AF 125A	S-N65	S-N50	22	22
	45	FR-A740-45K	225AF 175A	225AF 150A	S-N80	S-N65	38	38
	55	FR-A740-55K	225AF 200A	225AF 175A	S-N80	S-N80	60	60
	75	FR-A740-75K	—	225AF 225A	—	S-N95	60	60
	90	FR-A740-90K	—	225AF 225A	—	S-N150	60	60
	110	FR-A740-110K	—	225AF 225A	—	S-N180	80	80
	132	FR-A740-132K	—	400AF 400A	—	S-N220	100	125
	150	FR-A740-160K	—	400AF 400A	—	S-N300	125	150
	160	FR-A740-160K	—	400AF 400A	—	S-N300	125	150
	185	FR-A740-185K	—	400AF 400A	—	S-N300	150	150
	220	FR-A740-220K	—	600AF 500A	—	S-N400	2 × 100	2 × 100
250	FR-A740-250K	—	600AF 600A	—	S-N600	2 × 100	2 × 100	
280	FR-A740-280K	—	600AF 600A	—	S-N600	2 × 125	2 × 125	
315	FR-A740-315K	—	800AF 700A	—	S-N600	2 × 150	2 × 150	
355	FR-A740-355K	—	800AF 800A	—	S-N600	2 × 200	2 × 200	
400	FR-A740-400K	—	1000AF 900A	—	S-N800	2 × 200	2 × 200	
450	FR-A740-450K	—	1000AF 1000A	—	1000A rated product	2 × 250	2 × 250	
500	FR-A740-500K	—	1200AF 1200A	—	1000A rated product	2 × 250	2 × 250	

*1. Selections for use of the Mitsubishi 4-pole standard motor with power supply voltage 200VAC (200V class)/400VAC (400V class) 50Hz.

*2. Select the MCCB according to the inverter power supply capacity.

Install one MCCB per inverter.

For installations in the United States or Canada, use the appropriate UL and cUL listed Class RK5, class T

or Class L type fuse or molded case circuit breaker (MCCB).

For details, refer to the Instruction Manual (basic)



*3. Magnetic contactor is selected based on the AC-1 class. The electrical durability of magnetic contactor is 500,000 times. When the magnetic contactor is used for emergency stop during motor driving, the electrical durability is 25 times. When using the MC for emergency stop during motor driving or using on the motor side during commercial-power supply operation, select the class AC-3 rated current for the motor rated current.

*4. Cable

For the 55K or less, the cable size is that of the cable (HIV cable (600V class 2 vinyl-insulated cable) etc.) with continuous maximum permissible temperature of 75°C. Assumes that the ambient temperature is 50°C or less and the wiring distance is 20m or less.

For the 75K or more, the recommended cable size is that of the cable (e.g. LMFC (heat resistant flexible cross-linked polyethylene insulated cable)) with continuous maximum permissible temperature of 90°C. Assumes that the ambient temperature is 50°C or less and wiring is performed in an enclosure.

Selection of rated sensitivity current of earth (ground) leakage current breaker

When using the earth leakage current breaker with the inverter circuit, select its rated sensitivity current as follows, independently of the PWM carrier frequency.

- Breaker designed for harmonic and surge suppression
- Rated sensitivity current $I_{\Delta n} \geq 10 \times (I_{g1} + I_{gn} + I_{gi} + I_{g2} + I_{gm})$
- Standard breaker
- Rated sensitivity current $I_{\Delta n} \geq 10 \times \{(I_{g1} + I_{gn} + I_{gi} + 3 \times (I_{g2} + I_{gm}))\}$
- I_{g1}, I_{g2} : Leakage currents in wire path during commercial power supply operation
- I_{gn} : Leakage current of inverter input side noise filter
- I_{gm} : Leakage current of motor during commercial power supply operation
- I_{gi} : Inverter unit leakage current

Example of leakage current of cable path per 1km during the commercial power supply operation when the CV cable is routed in metal conduit (200V 60Hz)

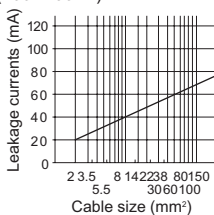

Leakage current example of three-phase induction motor during the commercial power supply operation (200V 60Hz)

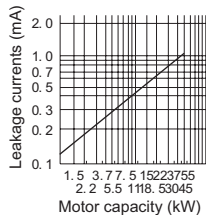

Example

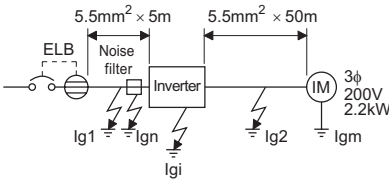

- Note: 1. Install the earth leakage current breaker (ELB) on the input side of the inverter.
 2. In the Δ connection earthed-neutral system, the sensitivity current is blunt against an earth (ground) fault in the inverter output side. Earthing (Grounding) must conform to the requirements of national and local safety regulations and electrical codes. (NEC section 250, IEC 536 class 1 and other applicable standards)

● Selection example (in the case of the left figure)

	Breaker Designed For Harmonic and Surge Suppression	Standard Breaker
Leakage current I_{g1} (mA)	$33 \times \frac{5m}{1,000m} = 0.17$	
Leakage current I_{gn} (mA)	0 (without noise filter)	
Leakage current I_{gi} (mA)	1 (without EMC filter) Refer to the following table for the leakage current of the inverter	
Leakage current I_{g2} (mA)	$33 \times \frac{50m}{1,000m} = 1.65$	
Motor leakage current I_{gm} (mA)	0.18	
Total leakage current (mA)	3.00	6.66
Rated sensitivity current (mA) ($\geq I_g \times 10$)	30	100

● Inverter leakage currents (with and without EMC filter)

Input power conditions
 (200V class: 220V/60Hz, 400V class: 440V/60Hz,
 power supply unbalance within 3%)

Earth (Ground)	Voltage (V)	EMC Filter	
		ON (mA)	OFF (mA)
Phase grounding	200	22 (1)*	1
	400	30	1
Earthed-neutral system	400	1	1

* For the 200V class 0.4K and 0.75K, the EMC filter is always valid. The leakage current is 1mA.

- Features
- Peripheral Devices
- Standard Specifications
- Outline Dimension Drawings
- Terminal Connection Diagram Terminal Specification Explanation
- Operation Panel
- Parameter List
- Explanations of Parameters
- Protective Functions
- Options
- Instructions
- Motor
- Compatibility
- Warranty
- Inquiry

Precautions for Operation/Selection

Precautions for use of the inverter

⚠ Safety Precautions

- To operate the inverter correctly and safely, be sure to read the "instruction manual" before starting operation.
- This product has not been designed or manufactured for use with any equipment or system operated under life-threatening conditions.
- Please contact our sales office when you are considering using this product in special applications such as passenger mobile, medical, aerospace, nuclear, power or undersea relay equipment or system.
- Although this product is manufactured under strict quality control, safety devices should be installed when a serious accident or loss is expected by a failure of this product.
- The load used should be a three-phase induction motor only.

Operation

- A magnetic contactor (MC) provided on the input side should not be used to make frequent starts and stops. It could cause the inverter to fail.
- However, at this time, the motor cannot be brought to a sudden stop. Hence, provide a mechanical stopping/holding mechanism for the machine/equipment which requires an emergency stop.
- It will take time for the capacitor to discharge after shutoff of the inverter power supply. When accessing the inverter for inspection, wait for at least 10 minutes after the power supply has been switched off, and check to make sure that there are no residual voltage using a tester or the like.

Wiring

- Application of power to the output terminals (U, V, W) of the inverter will damage the inverter. Therefore, fully check the wiring and sequence to ensure that wiring is correct, etc. before powering on.
- The terminals P/+, P1, N/- are provided for connection of a dedicated option. Connect only a dedicated option. Do not short the frequency setting power supply terminal 10 and common terminal 5 or the terminal PC and terminal SD.

Power supply

- When the inverter is connected under a large-capacity power transformer (1000kVA or more transformer) or when a power capacitor is to be switched over, an excessive peak current may flow in the power input circuit, damaging the inverter. To prevent this, always install an optional AC reactor (FR-HEL).

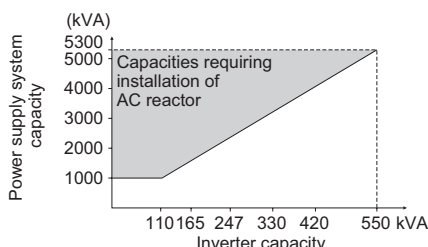

- If a surge voltage occurs in the power supply system, this surge energy may flow into the inverter, causing the inverter to display overvoltage protection (E.OV□) and come to an alarm stop. To prevent this, always install an optional AC reactor (FR-HAL).

Installation

- Avoid hostile environment where oil mist, fluff, dust particles, etc. are suspended in the air, and install the inverter in a clean place or put it in an ingress-protected "enclosed" enclosure. When placing the inverter in an enclosure, determine the cooling system and enclosure dimensions so that the ambient temperature of the inverter is within the permissible value. (refer to page 10 for the specified value)
- Do not install the inverter on wood or other combustible material as it will be hot locally.
- Install the inverter in the vertical orientation.

Setting

- The inverter can be operated as fast as a maximum of 400Hz by parameter setting. Therefore, incorrect setting can cause a danger. Set the upper limit using the maximum frequency limit setting function.
- A setting higher than the initial value of DC injection brake operation voltage or operation time can cause motor overheat (electronic thermal relay trip).

Real sensorless vector control

- Make sure to perform offline auto tuning before performing real sensorless vector control.
- The carrier frequencies are selectable from among 2k, 6k, 10k, 14kHz for real sensorless vector control.
- Torque control can not be performed in the low speed region and at a low speed with light load. Choose vector control.
- Performing pre-excitation (LX signal and X13 signal) under torque control may start the motor running at a low speed even when the start command (STF or STR) is not input. The motor may run also at a low speed when the speed limit value=0 with a start command input. Perform pre-excitation after making sure that there will be no problem in safety if the motor runs.
- Do not switch between the STF (forward rotation command) and STR (reverse rotation command) during operation under torque control. Overcurrent shut-off error (E.OC□) or opposite rotation deceleration error (E.11) occurs.
- For the 0.4K to 3.7K, the speed deviation may become large at 20Hz or less and torque may become insufficient in the low speed region under 1Hz during continuous operation under real sensorless vector control. In such case, stop operation once and reaccelerate to improve the problems.
- When the inverter is likely to start during motor coasting under real sensorless vector control, set to make frequency search of automatic restart after instantaneous power failure valid (Pr. 57 ≠ "9999", Pr. 162 = "10").
- The 22K does not comply with the 2nd environment of the EMC Directive.

Precautions for selection

Inverter capacity selection

- When operating a special motor or more than one motor in parallel with a single inverter, select the inverter capacity so that 1.1 times the total rated motor current is less than the rated output current of the inverter.

Starting torque of the motor

- The start and acceleration characteristics of the motor driven by the inverter are restricted by the overload current rating of that inverter. Generally the torque characteristic is less than when the motor is started by a commercial power supply. When torque boost adjustment, advanced magnetic flux vector, real sensorless vector or vector control cannot provide enough starting torque, select the inverter of one rank higher capacity or increase the capacities of both the motor and inverter.

Acceleration/deceleration times

- The acceleration/deceleration time of the motor depends on the motor-generated torque, load torque and load inertia moment (GD^2).
- When the torque limit function or stall prevention function is activated during acceleration/deceleration, increase the acceleration/deceleration time as the actual time may become longer.
- To decrease the acceleration/deceleration time, increase the torque boost value (setting of a too large value may activate the stall prevention function at a start, resulting in longer acceleration time), use the advanced magnetic flux vector control or real sensorless vector control, or increase the inverter and motor capacities. To decrease the deceleration time, it is necessary to add the brake unit (FR-BU, MT-BU5), power regeneration common converter (FR-CV), power regeneration unit (MT-RC) or a similar device to absorb braking energy.

Power transfer mechanism (reduction gear, belt, chain, etc.)

- When an oil-lubricated gear box, speed change/reduction gear or similar device is used in the power transfer system, note that continuous operation at low speed only may deteriorate oil lubrication, causing seizure. When performing fast operation at higher than 60Hz, fully note that such operation will cause strength shortage due to the noise, life or centrifugal force of the power transfer mechanism.

Instructions for overload operation

- When performing operation of frequent start/stop of the inverter, rise/fall in the temperature of the transistor element of the inverter will repeat due to a repeated flow of large current, shortening the life from thermal fatigue. Since thermal fatigue is related to the amount of current, the life can be increased by reducing current at locked condition, starting current, etc. Decreasing current may increase the life. However, decreasing current will result in insufficient torque and the inverter may not start. Therefore, choose the inverter which has enough allowance for current.

Features

Peripheral Devices

Standard Specifications

Outline Dimension Drawings

Terminal Connection Diagram Terminal Specification Explanation

Operation Panel

Parameter List

Explanations of Parameters

Protective Functions

Options

Instructions

Motor

Compatibility

Warranty

Inquiry

Precautions for Peripheral Device Selection

Installation and selection of moulded case circuit breaker

Install a moulded case circuit breaker (MCCB) on the power receiving side to protect the wiring of the inverter input side. For MCCB selection, refer to page 87 since it depends on the inverter power supply side power factor (which changes depending on the power supply voltage, output frequency and load). Especially for a completely electromagnetic MCCB, one of a slightly large capacity must be selected since its operation characteristic varies with harmonic currents. (Check it in the data of the corresponding breaker.) As an earth leakage current breaker, use the Mitsubishi earth leakage current breaker designed for harmonics and surge suppression. (Refer to page 88.)

When installing a moulded case circuit breaker on the output side of the inverter, check each manufacturer for selection of the moulded case circuit breaker.

Handling of primary side magnetic contactor

For operation via external terminal (terminal STF or STR used), provide an input side MC to prevent an accident caused by a natural restart at power recovery after a power failure, such as an instantaneous power failure, and to ensure safety for maintenance work. Do not use this magnetic contactor to make frequent starts and stops. (The switching life of the inverter input circuit is about 1,000,000 times.) For parameter unit operation, an automatic restart after power failure is not made and the MC cannot be used to make a start. Note that the primary side MC may be used to make a stop but the regenerative brake specific to the inverter does not operate and the motor is coasted to a stop.

Handling of the secondary side magnetic contactor

Switch the magnetic contactor between the inverter and motor only when both the inverter and motor are at a stop. When the magnetic contactor is turned on while the inverter is operating, overcurrent protection of the inverter and such will activate. When an MC is provided to switch to a commercial power supply, for example, it is recommended to use commercial power supply-inverter switchover operation Pr.135 to Pr.139.

Thermal relay installation

The inverter has an electronic thermal relay function to protect the motor from overheating. However, when running multiple motors with one inverter or operating a multi-pole motor, provide a thermal relay (OCR) between the inverter and motor. In this case, set the electronic thermal relay function of the inverter to 0A. And for the setting of the thermal relay, add the line-to-line leakage current (refer to page 92) to the current value on the motor rating plate.

For low-speed operation where the cooling capability of the motor reduces, it is recommended to use a thermal protector or thermistor-incorporated motor.

Measuring instrument on the output side

When the inverter-to-motor wiring length is large, especially in the 400V class, small-capacity models, the meters and CTs may generate heat due to line-to-line leakage current. Therefore, choose the equipment which has enough allowance for the current rating.

To measure and display the output voltage and output current of the inverter, it is recommended to use the terminal AM-5 output function of the inverter.

Disuse of power factor improving capacitor (power capacitor)

The power factor improving capacitor and surge suppressor on the inverter output side may be overheated or damaged by the harmonic components of the inverter output. Also, since an excessive current flows in the inverter to activate overcurrent protection, do not install a capacitor or surge suppressor. For power factor improvement, use a power factor improving DC reactor (see page 80).

Wire thickness and wiring distance

When the wiring length between the inverter and motor is long, use thick wires so that the voltage drop of the main circuit cable is 2% or less especially at low frequency output. (A selection example for the wiring distance of 20m is shown on page 87)

Especially at a long wiring distance, the maximum wiring length should be within the length in the table below since the overcurrent protection function may be misactivated by the influence of a charging current due to the stray capacitances of the wiring.

(The overall wiring length for connection of multiple motors should be within the value in the table below.)

Pr.72 PWM frequency selection setting (carrier frequency)	0.4K	0.75K	1.5K or more
2 or less	300m	500m	500m
3 to 15	200m	300m	500m

Use the recommended connection cable when installing the operation panel away from the inverter unit or when connecting the parameter unit.

For remote operation via analog signal, wire the control cable between the operation box or operation signal and inverter within 30m and away from the power circuits (main circuit and relay sequence circuit) to prevent induction from other devices.

When using the external potentiometer instead of the parameter unit to set the frequency, use a shielded or twisted cable, and do not earth (ground) the shield, but connect it to terminal 5 as shown below.

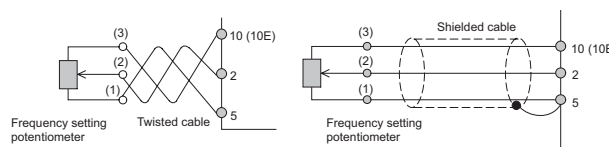

Earth (Ground)

When the inverter is run in the low acoustic noise mode, more leakage currents occur than in the non-low acoustic noise mode due to high-speed switching operation. Be sure to use the inverter and motor after grounding (earthing) them. In addition, always use the earth (ground) terminal of the inverter to earth (ground) the inverter. (Do not use the case and chassis)

Noise

When performing low-noise operation at higher carrier frequency, electromagnetic noise tends to increase. Therefore, refer to the following measure example and consider taking the measures. Depending on the installation condition, the inverter may be affected by noise in a non-low noise (initial) status.

- The noise level can be reduced by decreasing the carrier frequency (Pr.72).
- As measures against AM radio broadcasting noise and sensor malfunction, turning on the built-in EMC filter produces an effect. (For the switching method, refer to the instruction manual.)
- As measures against induction noise from the power cable of the inverter, providing a distance of 30cm (at least 10cm) or more and using a twisted pair shielded cable as a signal cable produces an effect. Do not earth (ground) shield but connect it to signal common cable.

Example of noise reduction techniques

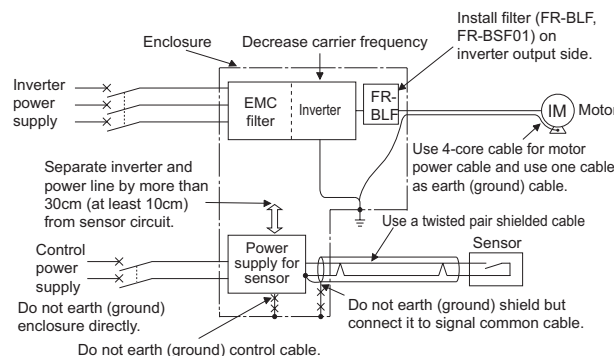

Application to standard motors

Motor loss and temperature rise

The motor operated by the inverter has a limit on the continuous operating torque since it is slightly higher in temperature rise than the one operated by a commercial power supply. At a low speed, reduce the output torque of the motor since the cooling effect decreases. When 100% torque is needed continuously at low speed, consider using a constant-torque motor.

Torque characteristic

The motor operated by the inverter may be less in motor torque (especially starting torque) than the one driven by the commercial power supply. It is necessary to fully check the load torque characteristic of the machine.

Motor torque

When the Mitsubishi standard squirrel-cage motor (SF-JR, 4-pole) and inverter of the same capacity are used, the torque characteristics are as shown below.

Maximum torque for short time

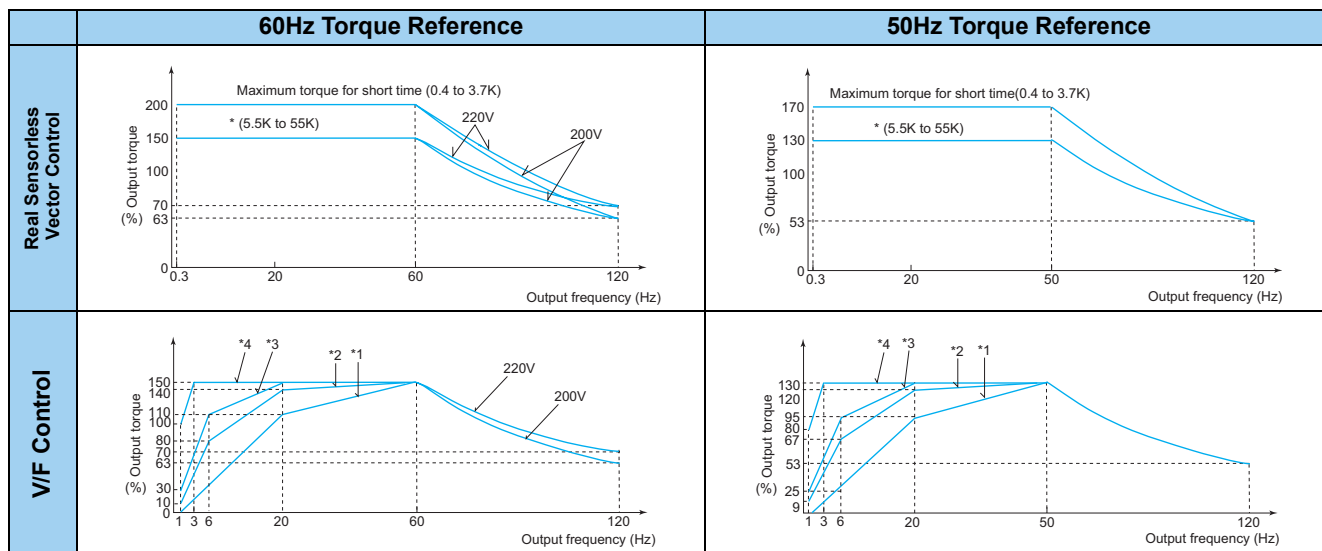

- 200% torque (60Hz torque reference) is output at 0.3Hz operation under real sensorless vector control. (0.4 to 3.7K)
(* 0.3Hz 150% torque for the 5.5K to 55K)
- A 60Hz torque reference indicates that the rated torque of the motor running at 60Hz is 100%, and a 50Hz torque reference indicates that the rated torque of the motor running at 50Hz is 100%

- *1. Torque boost minimum (0%)
- *2. Torque boost standard (initial value)
- *3. Torque boost large (0.4K, 0.75K... 10%, 1.5K to 3.7K... 7%, 5.5K, 7.5K... 6%, 11K or more... 4%)
- *4. Torque boost adjustment (3.7kW or less)

Continuous torque (real sensorless vector control)

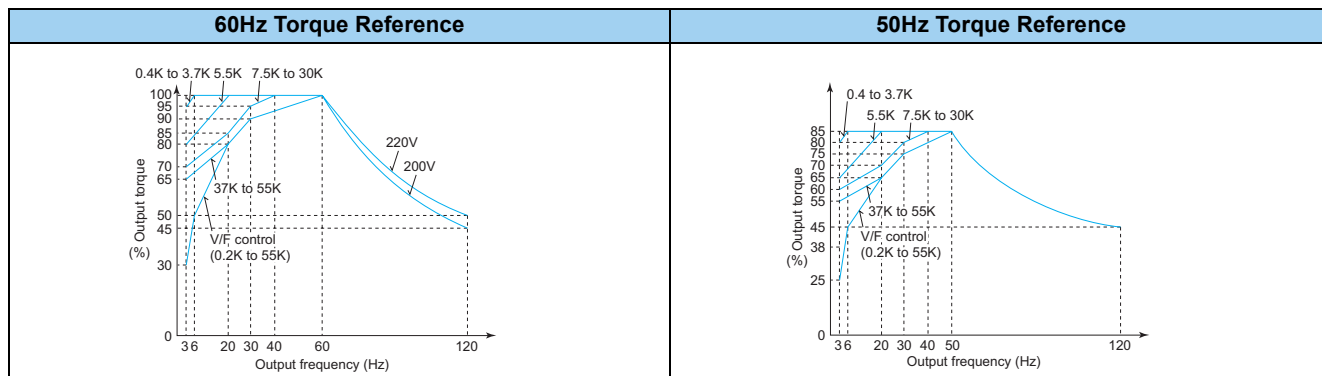

- A general-purpose, squirrel-cage motor must be used at lower continuous operating torque in rated operation as shown in the chart since the cooling capability of the fan installed on the rotor reduces at a lower speed. (Instantaneous torque occurs)
- 200/220V 60Hz or 200V 50Hz in the chart indicates a motor torque reference (base frequency set in Pr.3 of the inverter) and is not the frequency of the power supply. You can also set 60Hz in a 50Hz power supply area.
- As shown in the chart, the 60Hz torque reference setting allows you to use the motor more efficiently as it can bring out the 100% torque of the motor continuously.

Application to constant-torque motors

SF-HRCA type

- Continuous operation even at low speed of 0.3Hz is possible. (when using real sensorless vector control)
For the 37kW or less (except for 22kW), load torque is not need to be reduced even at a low speed and constant torque (100% torque) continuous operation is possible within the range of speed ratio 1/20 (3 to 60Hz). (The characteristic of motor running at 60Hz or more is that output torque is constant.)
- Installation size is the same as that of the standard motor
- ★ Note that operation characteristic in the chart below can not be obtained if V/F control is employed.

Standard specifications (indoor type)

Output (kW)	Number of Poles	Frequency Range	Common Specifications
0.4	4	3 to 120Hz	Standard frequency 60Hz ●Rotation direction (CCW) is counterclockwise when viewed from the motor end ●Lead wire 3.7kW or less.....3 pcs. 5.5kW or more...6 or 12 pcs. ●Ambient temperature: 40 °C maximum Protective structure is JP44
0.75			
1.5			
2.2			
3.7			
5.5			
7.5			
11			
15			
18.5			
22	3 to 100Hz		
30			
37			
45			
55			
	3 to 65Hz		

- Continuous rated range of use (real sensorless vector control)

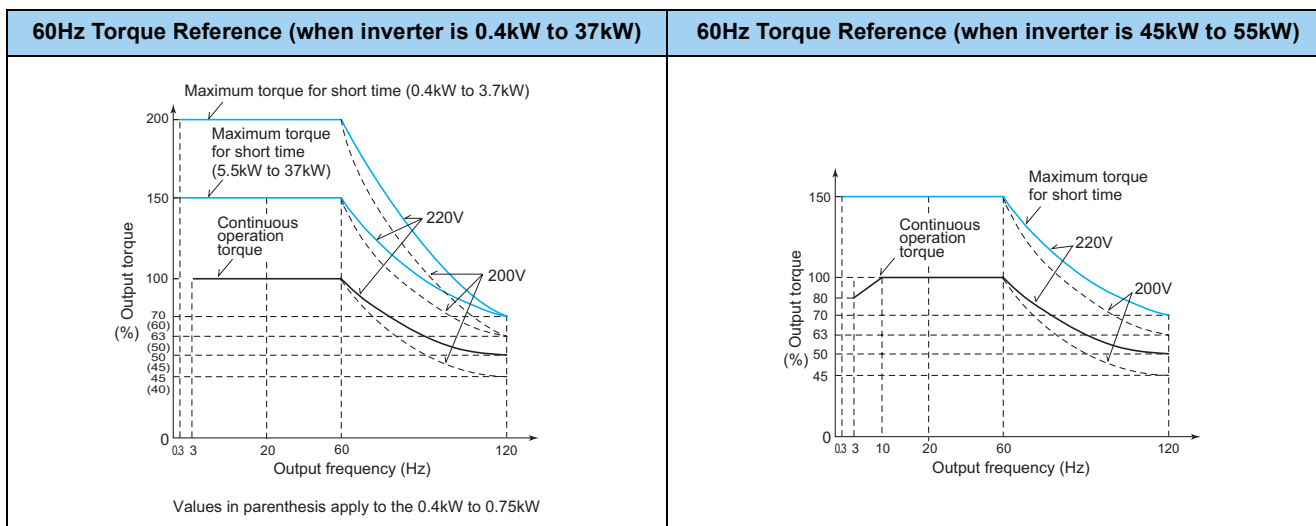

Please contact us separately for the motor constants during real sensorless vector control.

Application to vector control dedicated motors (SF-V5RU) (55kW or less)

Motor torque

When the vector control dedicated motor (SF-V5RU) and inverter are used, the torque characteristics are as shown below.

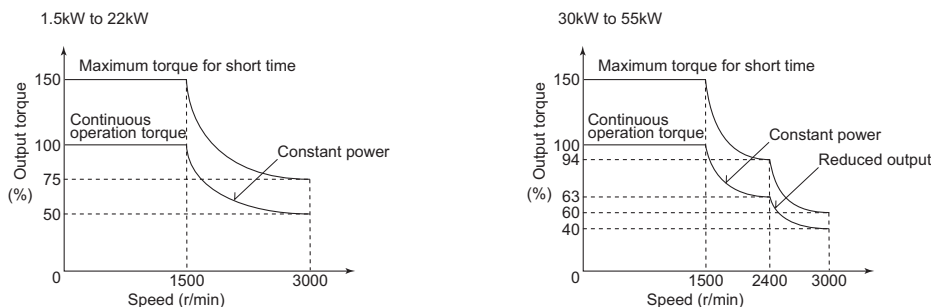

- Features
- Peripheral Devices
- Standard Specifications
- Outline Dimension Drawings
- Terminal Connection Diagram Terminal Specification Explanation
- Operation Panel
- Parameter List
- Explanations of Parameters
- Protective Functions
- Options
- Instructions
- Motor
- Compatibility
- Warranty
- Inquiry

Motor type

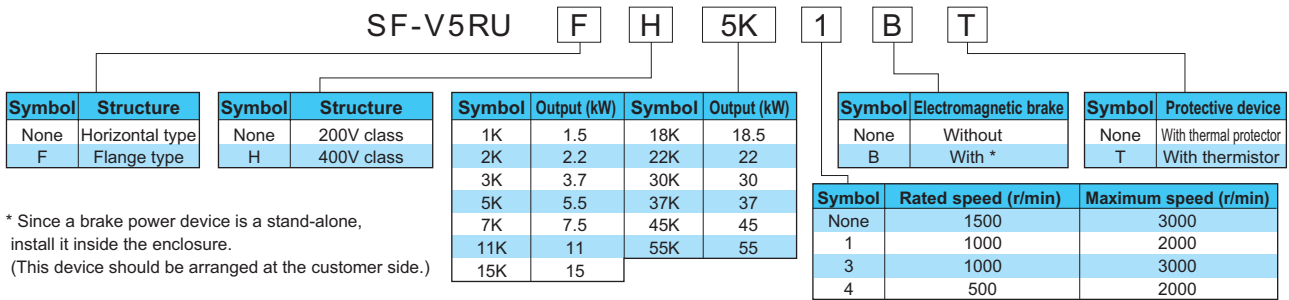

Dedicated motor model lineup

Rated speed: 1500r/min (4 pole)

Model	Standard type	Rated output (kW)	Flame number															
			1.5	2.2	3.7	5.5	7.5	11	15	18.5	22	30	37	45	55			
Standard horizontal type	SF-V5RU(H)□		90L	100L	112M	132S	132M	160M	160L	180M	180M	200L	200L	200L	225S			
Flange type	SF-V5RUF(H)□		●	●	●	●	●	●	●	●	●	●	●	●	●	—		
Standard horizontal type with brake	SF-V5RU(H)□B		●	●	●	●	●	●	●	●	●	●	●	●	●	●		
Flange type with brake	SF-V5RUF(H)□B		●	●	●	●	●	●	●	—	—	—	—	—	—	—		

Rated speed: 1000r/min (4 pole), Maximum speed: 2000r/min, speed ratio 1:2

Model	Standard type	Rated output (kW)	Flame number										
			1.5	2.2	3.7	5.5	7.5	11	15	18.5	22	30	37
Standard horizontal type	SF-V5RU(H)□1		100L	112M	132S	132M	160M	160L	180M	180L	200L	200L	225S
Flange type	SF-V5RUF(H)□1		●	●	●	●	●	●	●	●	●	●	—
Standard horizontal type with brake	SF-V5RU(H)□1B		●	●	●	●	●	●	●	●	●	●	●
Flange type with brake	SF-V5RUF(H)□1B		●	●	●	●	●	●	—	—	—	—	—

Rated speed: 1000r/min (4 pole), Maximum speed: 3000r/min, speed ratio 1:3

Model	Standard type	Rated output (kW)	Flame number									
			1.5	2.2	3.7	5.5	7.5	11	15	18.5	22	30
Standard horizontal type	SF-V5RU(H)□3		112M	132S	132M	160M	160L	180M	180L	200L	200L	225S
Flange type	SF-V5RUF(H)□3		●	●	●	●	●	●	●	●	●	—
Standard horizontal type with brake	SF-V5RU(H)□3B		●	●	●	●	●	●	●	●	●	●
Flange type with brake	SF-V5RUF(H)□3B		●	●	●	●	●	—	—	—	—	—

Rated speed: 500r/min (4 pole), Maximum speed: 2000r/min, speed ratio 1:4

Model	Standard type	Rated output (kW)	Flame number							
			1.5	2.2	3.7	5.5	7.5	11	15	
Standard horizontal type	SF-V5RU(H)□4		132M	160M	160L	180L	200L	225S	225S	
Flange type	SF-V5RUF(H)□4		●	●	●	●	●	—	—	
Standard horizontal type with brake	SF-V5RU(H)□4B		●	●	●	●	●	●	●	
Flange type with brake	SF-V5RUF(H)□4B		●	●	●	—	—	—	—	

●: Available models —: Not available

*: Since motors with frame No. 250 or more, 400V class, speed ratio 1:4 specifications are available as special products, consult our sales office.

Combination with the SF-V5RU1,3,4 , SF-THY and inverter

		SF-V5RU□1 (1:2)			SF-V5RU□3 (1:3)			SF-V5RU□4 (1:4)		
Voltage		200V class								
Rated speed		1000r/min			1000r/min			500r/min		
Base frequency		33.33Hz			33.33Hz			16.6Hz		
Maximum speed		2000r/min			3000r/min			2000r/min		
Motor capacity	Motor frame number	Motor type	Inverter type	Motor frame number	Motor type	Inverter type	Motor frame number	Motor type	Inverter type	
1.5kW	100L	SF-V5RU1K1	FR-A720-2.2K	112M	SF-V5RU1K3	FR-A720-2.2K	132M	SF-V5RU1K4	FR-A720-2.2K	
2.2kW	112M	SF-V5RU2K1	FR-A720-3.7K	132S	SF-V5RU2K3	FR-A720-3.7K	160M	SF-V5RU2K4	FR-A720-3.7K	
3.7kW	132S	SF-V5RU3K1	FR-A720-5.5K	132M	SF-V5RU3K3	FR-A720-5.5K	160L	SF-V5RU3K4	FR-A720-7.5K	
5.5kW	132M	SF-V5RU5K1	FR-A720-7.5K	160M	SF-V5RU5K3	FR-A720-7.5K	180L	SF-V5RU5K4	FR-A720-7.5K	
7.5kW	160M	SF-V5RU7K1	FR-A720-11K	160L	SF-V5RU7K3	FR-A720-11K	200L*2	SF-V5RU7K4	FR-A720-11K	
11kW	160L	SF-V5RU11K1	FR-A720-15K	180M	SF-V5RU11K3	FR-A720-15K	225S*2	SF-V5RU11K4	FR-A720-15K	
15kW	180M	SF-V5RU15K1	FR-A720-18.5K	180L	SF-V5RU15K3	FR-A720-18.5K	225S*2	SF-V5RU15K4	FR-A720-22K	
18.5kW	180L	SF-V5RU18K1	FR-A720-22K	200L*2	SF-V5RU18K3	FR-A720-22K	250MD*2	SF-THY	FR-A720-22K	
22kW	200L	SF-V5RU22K1	FR-A720-30K	200L*2	SF-V5RU22K3	FR-A720-30K	280MD*2	SF-THY	FR-A720-30K	
30kW	200L	SF-V5RU30K1	FR-A720-37K	225S*1	SF-V5RU30K3	FR-A720-37K	280MD*2	SF-THY	FR-A720-37K	
37kW	225S	SF-V5RU37K1	FR-A720-45K	250MD*1	SF-THY	FR-A720-45K	280MD*2	SF-THY	FR-A720-45K	
45kW	250MD	SF-THY	FR-A720-55K	250MD*1	SF-THY	FR-A720-55K	280MD*2	SF-THY	FR-A720-55K	
55kW	250MD	SF-THY	FR-A720-75K	280MD*1	SF-THY	FR-A720-75K	280L*2	SF-THY	FR-A720-75K	

Models in the shaded parts and 400V class are developed upon receipt of order.

*1 The maximum speed is 2400r/min.

*2 80% output in the high-speed range. (The output is reduced when the speed is 2400r/min or more. Contact us separately for details.)

Motor specification

●200V class (Mitsubishi dedicated motor [SF-V5RU (1500r/min series)])

Motor type SF-V5RU□□K	1	2	3	5	7	11	15	18	22	30	37	45	55
Applicable inverter model FR-A720-□□K	2.2	3.7	5.5	7.5	11	15	18.5	22	30	37	45	55	75
Rated output (kW)	1.5	2.2	3.7	5.5	7.5	11	15	18.5	22	30	37	45	55
Rated torque (N·m)	9.55	14.1	23.6	35.0	47.7	70.0	95.5	118	140	191	235	286	350
Maximum torque 150% 60s (N·m)	14.3	21.1	35.4	52.4	71.6	105	143	176	211	287	353	429	525
Rated speed (r/min)	1500												
Maximum speed (r/min)	3000 *1												2400
Frame No.	90L	100L	112M	132S	132M	160M	160L	180M	180M	200L	200L	200L	225S
Inertia moment J (×10 ⁻⁴ kg·m ²)	67.5	105	175	275	400	750	875	1725	1875	3250	3625	3625	6850
Noise *4	75dB or less									80dB or less			85dB or less
Cooling fan (with thermal protector)	Voltage	Single-phase 200V/50Hz Single-phase 200V to 230V/60Hz						Three-phase 200V/50Hz Three-phase 200 to 230V/60Hz					
	Input *2	36/55W (0.26/0.32A)			22/28W (0.11/0.13A)			55/71W (0.39/0.39A)			100/156W (0.47/0.53A)		85/130W (0.46/0.52A)
Surrounding air temperature, humidity	-10 to +40°C (non-freezing), 90%RH or less (non-condensing)												
Structure (Protective structure)	Totally enclosed forced draft system (Motor: IP44, cooling fan: IP23S) *3												
Detector	Encoder 2048P/R, A phase, B phase, Z phase +12VDC power supply												
Equipment	Encoder, thermal protector, fan												
Heat resistance class	F												
Vibration rank	V10												
Approx. mass (kg)	24	33	41	52	62	99	113	138	160	238	255	255	320

●400V class (Mitsubishi dedicated motor [SF-V5RUH (1500r/min series)])

Motor type SF-V5RUH□□K	1	2	3	5	7	11	15	18	22	30	37	45	55
Applicable inverter model FR-A740-□□K	2.2	2.2	3.7	7.5	11	15	18.5	22	30	37	45	55	75
Rated output (kW)	1.5	2.2	3.7	5.5	7.5	11	15	18.5	22	30	37	45	55
Rated torque (N·m)	9.55	14.1	23.6	35.0	47.7	70.0	95.5	118	140	191	235	286	350
Maximum torque 150% 60s (N·m)	14.3	21.1	35.4	52.4	71.6	105	143	176	211	287	353	429	525
Rated speed (r/min)	1500												
Maximum speed (r/min)	3000 *1												2400
Frame No.	90L	100L	112M	132S	132M	160M	160L	180M	180M	200L	200L	200L	225S
Inertia moment J (×10 ⁻⁴ kg·m ²)	67.5	105	175	275	400	750	875	1725	1875	3250	3625	3625	6850
Noise *4	75dB or less									80dB or less			85dB or less
Cooling fan (with thermal protector)	Voltage	Single-phase 200V/50Hz Single-phase 200V to 230V/60Hz						Three-phase 380 to 400V/50Hz Three-phase 400 to 460V/60Hz					
	Input *2	36/55W (0.26/0.32A)			22/28W (0.11/0.13A)			55/71W (0.19/0.19A)			100/156W (0.27/0.30A)		85/130W (0.23/0.26A)
Surrounding air temperature, humidity	-10 to +40°C (non-freezing), 90%RH or less (non-condensing)												
Structure (Protective structure)	Totally enclosed forced draft system (Motor: IP44, cooling fan: IP23S) *3												
Detector	Encoder 2048P/R, A phase, B phase, Z phase +12VDC power supply												
Equipment	Encoder, thermal protector, fan												
Heat resistance class	F												
Vibration rank	V10												
Approx. mass (kg)	24	33	41	52	62	99	113	138	160	238	255	255	320

*1 A dedicated motor of 3.7kW or less can be run at the maximum speed of 3600 r/min. Consult our sales office when using the motor at the maximum speed.

*2 Power (current) at 50Hz/60Hz.

*3 Since a motor with brake has a window for gap check, the protective structure of both the cooling fan section and brake section is IP20. S of IP23S is an additional code indicating the condition that protection from water intrusion is established only when a cooling fan is not operating.

*4 The value when high carrier frequency is set (Pr.72 = 6, Pr.240 = 0).

Features
Peripheral Devices
Standard Specifications
Outline Dimension Drawings
Terminal Connection Diagram Terminal Specification Explanation
Operation Panel
Parameter List
Explanations of Parameters
Protective Functions
Options
Instructions
Motor
Compatibility
Warranty
Inquiry

Dedicated motor outline dimension drawings (standard horizontal type)

Frame Number 90L
SF-V5RU(H) 1K

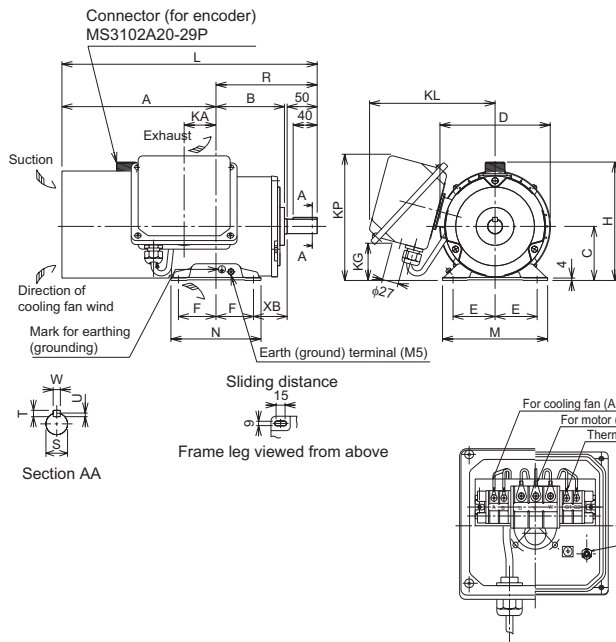

Frame Number 100L, 112M, 132S, 132M
SF-V5RU(H) 2K, 3K, 5K, 7K

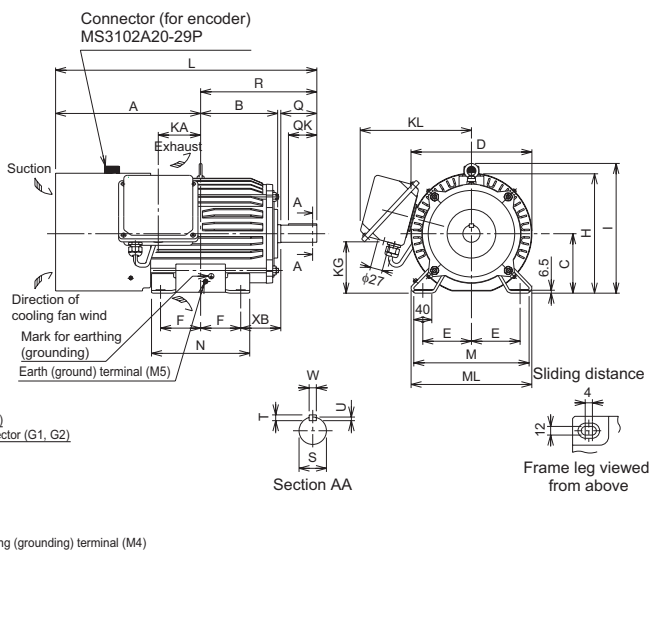

Frame Number 160M, 160L, 180M, 180L
SF-V5RU(H) 11K, 15K, 18K, 22K

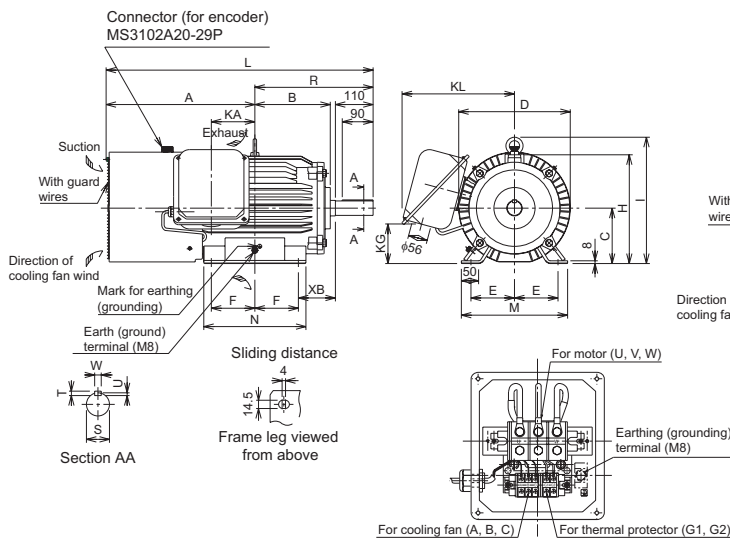

Frame Number 200L, 225S
SF-V5RU(H) 30K, 37K, 45K, 55K

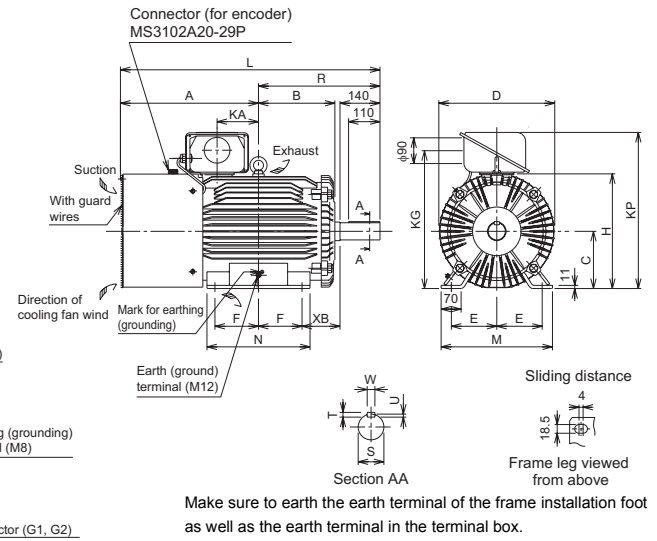

Make sure to earth the earth terminal of the frame installation foot as well as the earth terminal in the terminal box.

Dimensions table

(Unit: mm)

SF-V5RU □K	SF-V5RU □K1	SF-V5RU □K3	SF-V5RU □K4	Frame No.	Mass (kg)	Motor																				Terminal Screw Size					
						A	B	C	D	E	F	H	I	KA	KG	KL(KP)	L	M	ML	N	XB	Q	QK	R	S	T	U	W	UY,W	AB,C	G1,G2
1	—	—	—	90L	24	256.5	114	90	183.6	70	62.5	198	—	53	65	220(210)	425	175	—	150	56	—	—	168.5	24j6	7	4	8	M6	M4	M4
2	1	—	—	100L	33	284	128	100	207	80	70	203.5	230	65	78	231	477	200	212	180	63	60	45	193	28j6	7	4	8	M6	M4	M4
3	2	1	—	112M	41	278	135	112	228	95	70	226	253	69	93	242	478	230	242	180	70	60	45	200	28j6	7	4	8	M6	M4	M4
5	3	2	—	132S	52	303	152	132	266	108	70	265	288	75	117	256	542	256	268	180	89	80	63	239	38k6	8	5	10	M6	M4	M4
7	5	3	1	132M	62	322	171	132	266	108	89	265	288	94	117	256	580	256	268	218	89	80	63	258	38k6	8	5	10	M6	M4	M4
11	7	5	2	160M	99	412	198	160	318	127	105	316	367	105	115	330	735	310	—	254	108	—	—	323	42k6	8	5	12	M8	M4	M4
15	11	7	3	160L	113	434	220	160	318	127	127	316	367	127	115	330	779	310	—	298	108	—	—	345	42k6	8	5	12	M8	M4	M4
18	—	—	—	180M	138	438.5	225.5	180	363	139.5	120.5	359	410	127	139	352	790	335	—	285	121	—	—	351.5	48k6	9	5.5	14	M8	M4	M4
22	15	11	—	180L	160	457.5	242.5	180	363	139.5	139.5	359	410	146	139	352	828	335	—	323	121	—	—	370.5	56m6	10	6	16	M8	M4	M4
30	—	—	—	200L	238	483.5	267.5	200	406	159	152.5	401	—	145	487	(546)	909	390	—	361	133	—	—	425.5	60m6	—	—	—	M10	M4	M4
37, 45	22, 30	18, 22	—	225S	320	500	277	225	446	178	143	446	—	145	533	(592)	932	428	—	342	149	—	—	432	65m6	—	—	—	M10	M4	M4

- Note) 1. Install the motor on the floor and use it with the shaft horizontal.
 2. Leave an enough clearance between the fan suction port and wall to ensure adequate cooling.
 Also, check that the ventilation direction of a fan is from the opposite load side to the load side.
 3. The size difference of top and bottom of the shaft center height is 0.5.
 4. The 400V class motor has -H at the end of its type name.

Dedicated motor outline dimension drawings (1500r/min series) (standard horizontal type with brake)

Frame Number 90L
SF-V5RU(H) 1KB

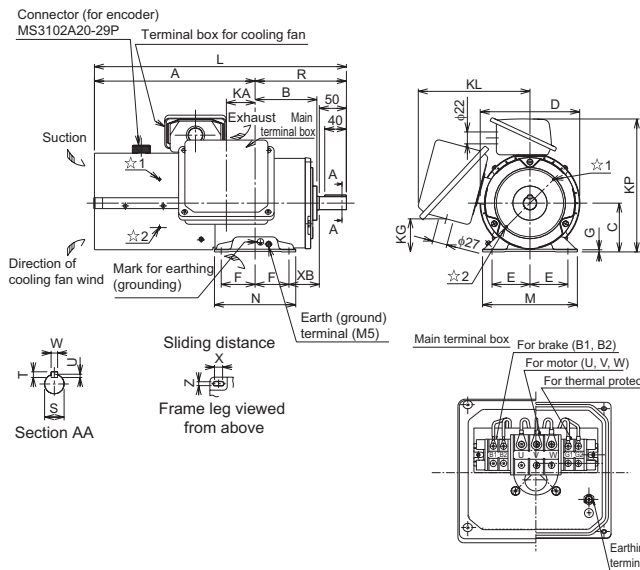

Frame Number 100L, 112M, 132S, 132M
SF-V5RU(H) 2KB, 3KB, 5KB, 7KB

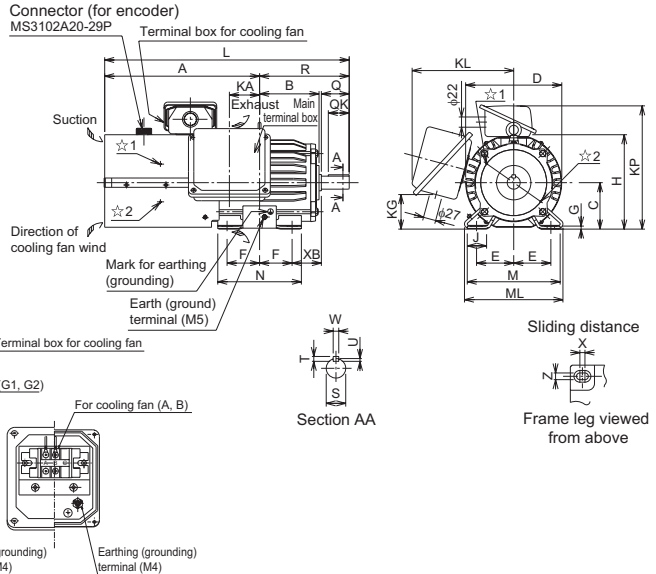

Frame Number 160M, 160L, 180M, 180L
SF-V5RU(H) 11KB, 15KB, 18KB, 22KB

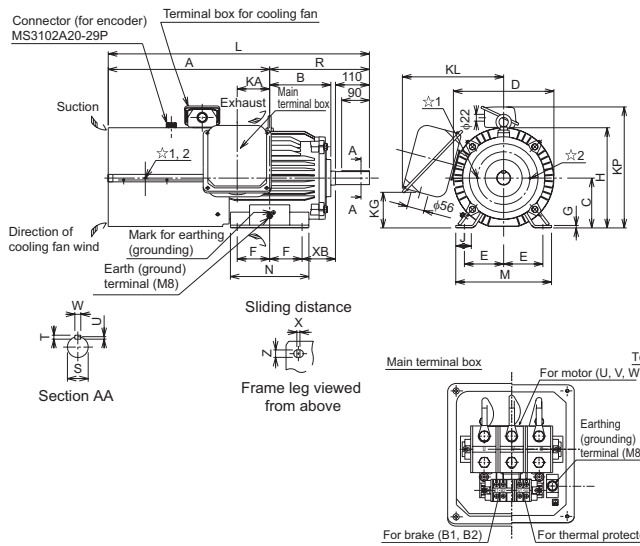

Frame Number 200L, 225S
SF-V5RU(H) 30KB, 37KB, 45KB, 55KB

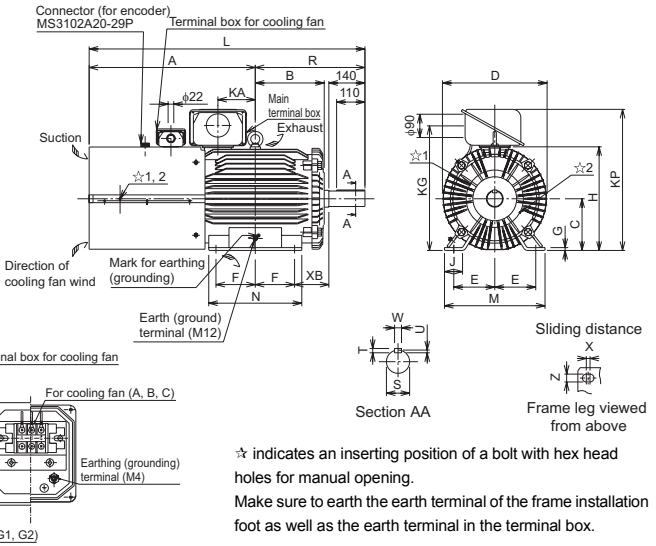

☆ indicates an inserting position of a bolt with hex head holes for manual opening.
Make sure to earth the earth terminal of the frame installation foot as well as the earth terminal in the terminal box.

Dimensions table

(Unit: mm)

SF-V5RU □K	SF-V5RU □K1	SF-V5RU □K3	SF-V5RU □K4	Frame No.	Mass (kg)	Motor																	Shaft End							Terminal Screw Size								
						A	B	C	D	E	F	G	H	I	J	KA	KD	KG	KL	KP	L	M	ML	N	X	XB	Z	Q	QK	R	S	T	U	W	U.V.W	A.B.C	G1	G2
1	—	—	—	90L	29	286.5	114	90	183.6	70	62.5	4	—	—	53	27	65	220	245	465	175	—	150	15	56	9	50	40	168.5	246	7	4	8	M6	M4	M4	M4	
2	1	—	—	100L	46	333.5	128	100	207	80	70	6.5	—	—	40	65	27	78	231	265	528.5	200	212	180	4	63	12	60	45	193	286	7	4	8	M6	M4	M4	M4
3	2	1	—	112M	53	355	135	112	228	95	70	6.5	—	—	40	69	27	93	242	290	555	230	242	180	4	70	12	60	45	200	286	7	4	8	M6	M4	M4	M4
5	3	2	—	132S	70	416	152	132	266	108	70	6.5	—	—	40	75	27	117	256	329	655	256	268	180	4	89	12	80	63	239	386	8	5	10	M6	M4	M4	M4
7	5	3	1	132M	80	435	171	132	266	108	89	6.5	—	—	40	94	27	117	256	329	693	256	268	218	4	89	12	80	63	258	386	8	5	10	M6	M4	M4	M4
11	7	5	2	160M	140	522.5	198	160	318	127	105	8	—	—	50	105	56	115	330	391	845.5	310	—	254	4	108	14.5	110	90	323	426	8	5	12	M8	M4	M4	M4
15	11	7	3	160L	155	544.5	220	160	318	127	127	8	—	—	50	127	56	115	330	391	889.5	310	—	298	4	108	14.5	110	90	345	426	8	5	12	M8	M4	M4	M4
18	—	—	—	180M	185	588.5	225.5	180	363	138.5	120.5	8	—	—	50	127	56	139	352	428	920	335	—	285	4	121	14.5	110	90	351.5	486	9	5.5	14	M8	M4	M4	M4
22	15	11	—	180L	215	587.5	242.5	180	363	138.5	138.5	8	—	—	50	146	56	139	352	428	958	335	—	323	4	121	14.5	110	90	370.5	556	10	6	16	M8	M4	M4	M4
30	—	—	—	200L	305	644.5	267.5	200	406	159	152.5	11	—	—	70	145	90	487	—	546	1070	390	—	361	4	133	18.5	140	110	425.5	606	11	7	18	M10	M4	M4	M4
37, 45	22, 30	18, 22	—	225S	330	659	277	225	446	178	143	11	—	—	70	145	90	533	—	592	1091	428	—	342	4	149	18.5	140	110	432	656	11	7	18	M10	M4	M4	M4

1. Install the motor on the floor and use it with the shaft horizontal.
2. Leave an enough clearance between the fan suction port and wall to ensure adequate cooling.
Also, check that the ventilation direction of a fan is from the opposite load side to the load side.
3. The size difference of top and bottom of the shaft center height is 3.5.
4. The 400V class motor has -H at the end of its type name.
5. Since a brake power device is a stand-alone, install it inside the enclosure.
(This device should be arranged at the customer side.)

- Features
- Peripheral Devices
- Standard Specifications
- Outline Dimension Drawings
- Terminal Connection Diagram Terminal Specification Explanation
- Operation Panel
- Parameter List
- Explanations of Parameters
- Protective Functions
- Options
- Instructions
- Motor
- Compatibility
- Warranty
- Inquiry

Dedicated motor outline dimension drawings (1500r/min series) (flange type)

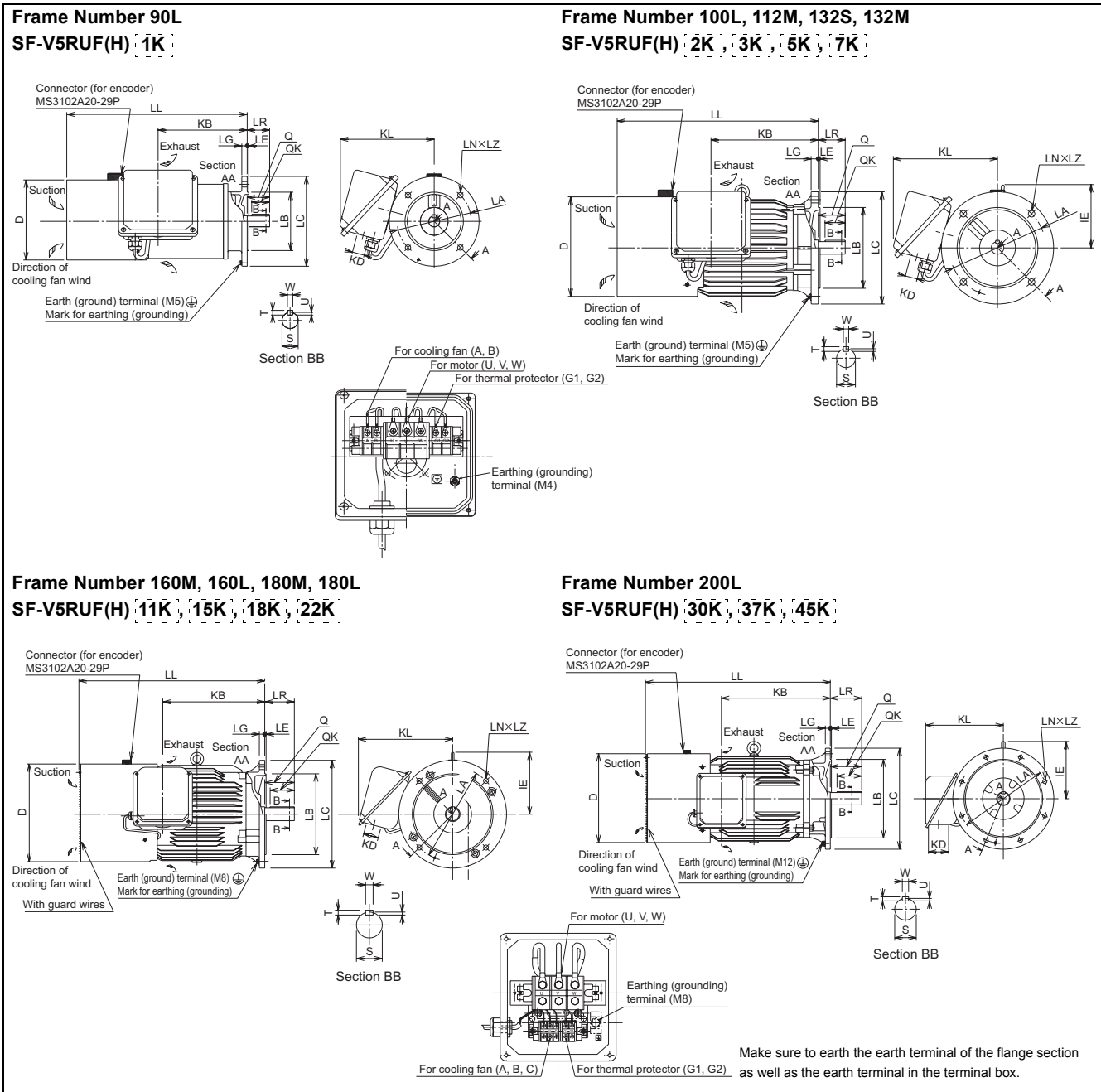

Dimensions table

(Unit: mm)

SF-V5RU □K	SF-V5RU □K1	SF-V5RU □K3	SF-V5RU □K4	Flange Number	Frame No.	Mass (kg)	Motor													Shaft End						Terminal Screw Size					
							D	IE	KB	KD	KL	LA	LB	LC	LE	LG	LL	LN	LZ	LR	Q	QK	S	T	U	W	U,V,W	A,B,C	G1,G2		
1	—	—	—	FF165	90L	26.5	183.6	—	198.5	27	220	165	130	6	200	3.5	12	402	4	12	50	50	40	24	6	7	4	8	M6	M4	M4
2	1	—	—	FF215	100L	37	207	130	213	27	231	215	180	6	250	4	16	432	4	14.5	60	60	45	28	6	7	4	8	M6	M4	M4
3	2	1	—	FF215	112M	46	228	141	239	27	242	215	180	6	250	4	16	448	4	14.5	60	60	45	28	6	7	4	8	M6	M4	M4
5	3	2	—	FF265	132S	65	266	156	256	27	256	265	230	6	300	4	20	484	4	14.5	80	80	63	38	6	8	5	10	M6	M4	M4
7	5	3	1	FF265	132M	70	266	156	294	27	256	265	230	6	300	4	20	522	4	14.5	80	80	63	38	6	8	5	10	M6	M4	M4
11	7	5	2	FF300	160M	110	318	207	318	56	330	300	250	6	350	5	20	625	4	18.5	110	110	90	42	6	8	5	12	M8	M4	M4
15	11	7	3	FF300	160L	125	318	207	362	56	330	300	250	6	350	5	20	669	4	18.5	110	110	90	42	6	8	5	12	M8	M4	M4
18	—	—	—	—	—	160	—	—	—	—	—	—	—	—	—	—	—	—	—	—	—	—	—	—	—	—	—	—	—	—	—
22	15	11	—	FF350	180M	185	363	230	378.5	56	352	350	300	6	400	5	20	690	4	18.5	110	110	90	48	6	9	5.5	14	M8	M4	M4
—	18	15	5	FF350	180L	225	363	230	416.5	56	352	350	300	6	400	5	20	728	4	18.5	110	110	90	55	6	10	6	16	M8	M4	M4
30	—	—	7	—	—	270	—	—	—	—	—	—	—	—	—	—	—	—	—	—	—	—	—	—	—	—	—	—	—	—	—
37, 45	22, 30	18, 22	—	FF400	200L	290	406	255	485	90	346	400	350	6	450	5	22	823.5	8	18.5	140	140	110	60	6	11	7	18	M10	M4	M4

- Note) 1. Install the motor on the floor and use it with the shaft horizontal.
For use under the shaft, the protection structure of the cooling fan is IP20.
2. Leave an enough clearance between the fan suction port and wall to ensure adequate cooling.
Also, check that the ventilation direction of a fan is from the opposite load side to the load side.
3. The size difference of top and bottom of the shaft center height is ± 0.5 .
4. The 400V class motor has -H at the end of its type name.

Dedicated motor outline dimension drawings (1500r/min series) (flange type with brake)

Frame Number 90L
SF-V5RUF(H) 1KB

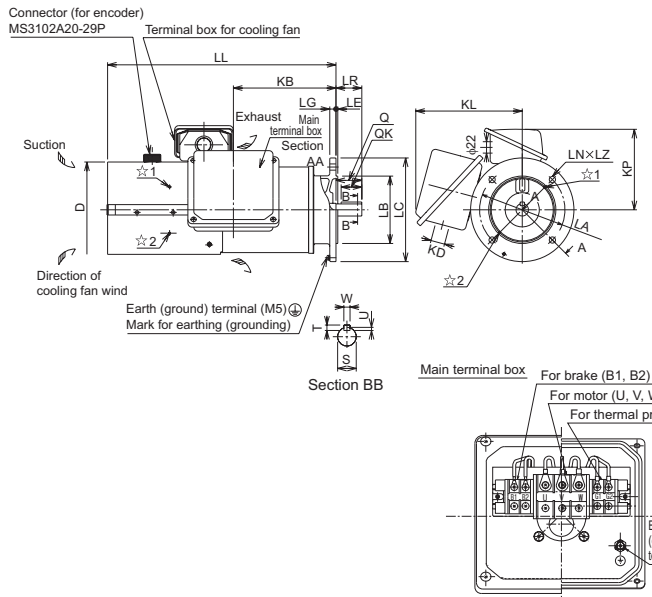

Frame Number 100L, 112M, 132S, 132M
SF-V5RUF(H) 2KB, 3KB, 5KB, 7KB

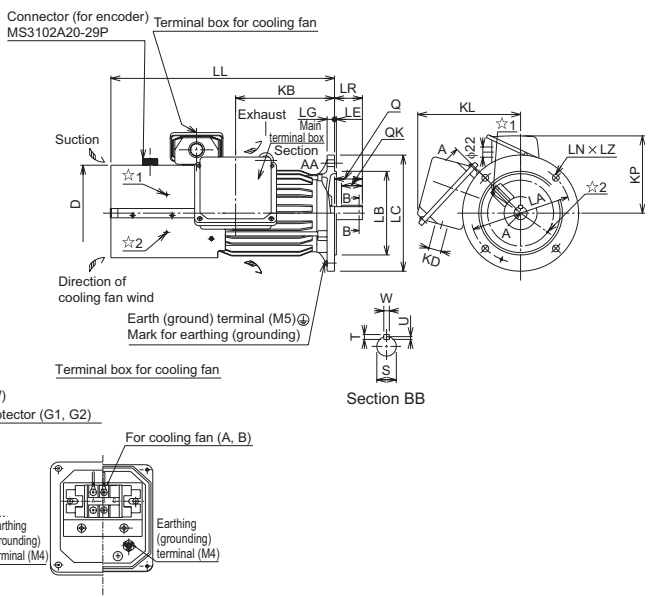

Frame Number 160M, 160L
SF-V5RUF(H) 11KB, 15KB

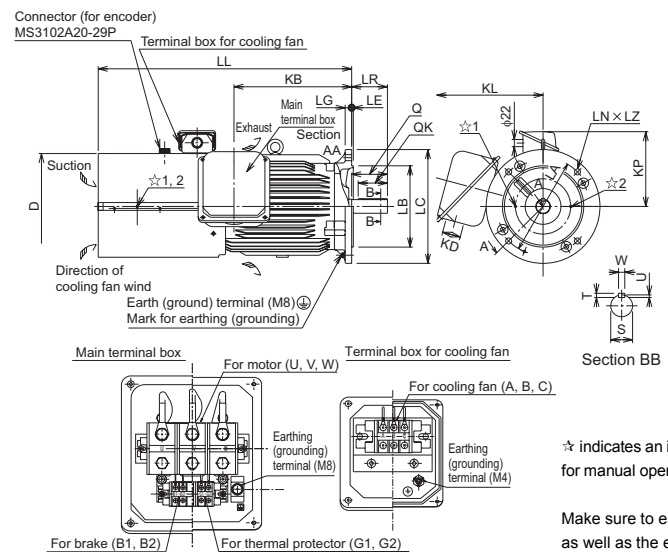

☆ indicates an inserting position of a bolt with hex head holes for manual opening.
Make sure to earth the earth terminal of the flange section as well as the earth terminal in the terminal box.

Dimensions table

(Unit: mm)

SF-V5RU □K	SF-V5RU □K1	SF-V5RU □K3	SF-V5RU □K4	Flange Number	Frame No.	Mass (kg)	Motor												Shaft End					Terminal Screw Size						
							D	KB	KD	KL	KP	LA	LB	LC	LE	LG	LL	LN	LZ	LR	Q	QK	S	T	U	W	U,V,W	A,B,C	B1,B2	G1,G2
1	—	—	—	FF165	90L	31.5	183.6	198.5	27	220	155	165	130j6	200	3.5	12	442	4	12	50	50	40	24j6	7	4	8	M6	M4	M4	M4
2	1	—	—	FF215	100L	50	207	213	27	231	165	215	180j6	250	4	16	481.5	4	14.5	60	60	45	28j6	7	4	8	M6	M4	M4	M4
3	2	1	—	FF215	112M	58	228	239	27	242	178	215	180j6	250	4	16	525	4	14.5	60	60	45	28j6	7	4	8	M6	M4	M4	M4
5	3	2	—	FF265	132S	83	266	256	27	256	197	265	230j6	300	4	20	597	4	14.5	80	80	63	38k6	8	5	10	M6	M4	M4	M4
7	5	3	1	FF265	132M	88	266	294	27	256	197	265	230j6	300	4	20	635	4	14.5	80	80	63	38k6	8	5	10	M6	M4	M4	M4
11	7	5	2	FF300	160M	151	318	318	56	330	231	300	250j6	350	5	20	735.5	4	18.5	110	110	90	42k6	8	5	12	M8	M4	M4	M4
15	11	7	3	FF300	160L	167	318	362	56	330	231	300	250j6	350	5	20	779.5	4	18.5	110	110	90	42k6	8	5	12	M8	M4	M4	M4

- Note) 1. Install the motor on the floor and use it with the shaft horizontal.
 2. Leave an enough clearance between the fan suction port and wall to ensure adequate cooling.
 Also, check that the ventilation direction of a fan is from the opposite load side to the load side.
 3. The size difference of top and bottom of the shaft center height is $\frac{3}{5}$.
 4. The 400V class motor has -H at the end of its type name.
 5. Since a brake power device is a stand-alone, install it inside the enclosure.
 (This device should be arranged at the customer side.)

- Features
- Peripheral Devices
- Standard Specifications
- Outline Dimension Drawings
- Terminal Connection Diagram Terminal Specification Explanation
- Operation Panel
- Parameter List
- Explanations of Parameters
- Protective Functions
- Options
- Instructions
- Motor
- Compatibility
- Warranty
- Inquiry

Application to vector dedicated motor (SF-THY) (frame No. 250 or more)

Motor torque

When the vector dedicated motor (SF-THY) and inverter of the same capacity are used and rated voltage is input, the torque characteristics are as shown below.

<75[kW]>

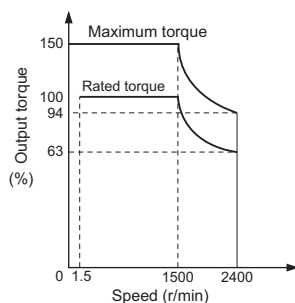

<90 to 250[kW]>

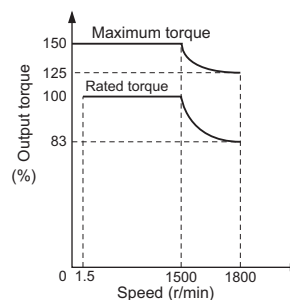

Dedicated motor model lineup

Rated speed: 1500r/min (4 poles)

Model	Standard Type	Rated Output (kW)						
		75	90	110	132	160	200	250
Standard horizontal type	SF-THY□	75	90	110	132	160	200	250

Note) Both 200V and 400V are the same type.

Since motors with the speed ratio of 1:2, 1:3, and 1:4 are available as special products, consult our sales office.

Motor specifications

200V class	Motor type	SF-THY							
	Applicable inverter FR-A720-□□K	90							
	Rated output(kW)	75							
	Rated torque (kgf*m) (N*m)	48.7							
		477							
	Maximum torque (kgf*m) 150%60s (N*m)	73.0							
		715							
	Rated speed (r/min)	1500							
	Maximum speed (r/min)	2400							
	Frame No.	250MD							
	Inertia moment J (kg*m ²)	1.1							
Noise	90dB								
Cooling fan	Voltage	Three-phase, 200V/50Hz, 200V/60Hz, 220V/60Hz (400V class cooling fan is available upon order)							
	Input (W)	750							
Approx. mass (kg)	610								
400V class	Motor type	SF-THY							
	Applicable inverter FR-A740-□□K	90	110	132	160	185	220	280	
	Rated output (kW)	75	90	110	132	160	200	250	
	Rated torque (kgf*m) (N*m)	48.7	58.4	71.4	85.7	103.9	129.9	162.3	
		477	572	700	840	1018	1273	1591	
	Maximum torque (kgf*m) 150%60s (N*m)	73.0	87.6	107.1	128.5	155.8	194.8	243.4	
		715	858	1050	1260	1527	1909	2386	
	Rated speed (r/min)	1500							
	Maximum speed (r/min)	2400	1800						
	Frame No.	250MD	250MD	280MD	280MD	280MD	280L	315H	
	Inertia moment J (kg*m ²)	1.1	1.7	2.3	2.3	4.0	3.8	5.0	
	Noise	90dB				95dB			
	Cooling fan	Voltage	Three-phase, 200V/50Hz, 200V/60Hz, 220V/60Hz (400V class cooling fan is available upon order)						
Input (W)		50Hz	400	400	400	400	400	750	750
		60Hz	750	750	750	750	750	1500	1500
Approx. mass (kg)	610	660	870	890	920	1170	1630		

Dedicated motor outline dimension drawings (1500r/min series)

Frame Number 250MD, 280MD
75kW to 160kW

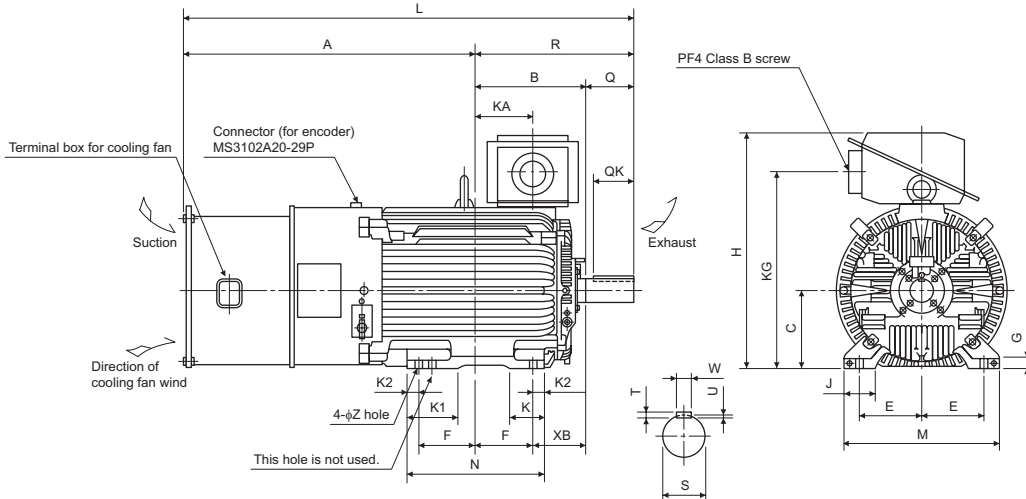

Frame Number 280L, 315H
200kW, 250kW

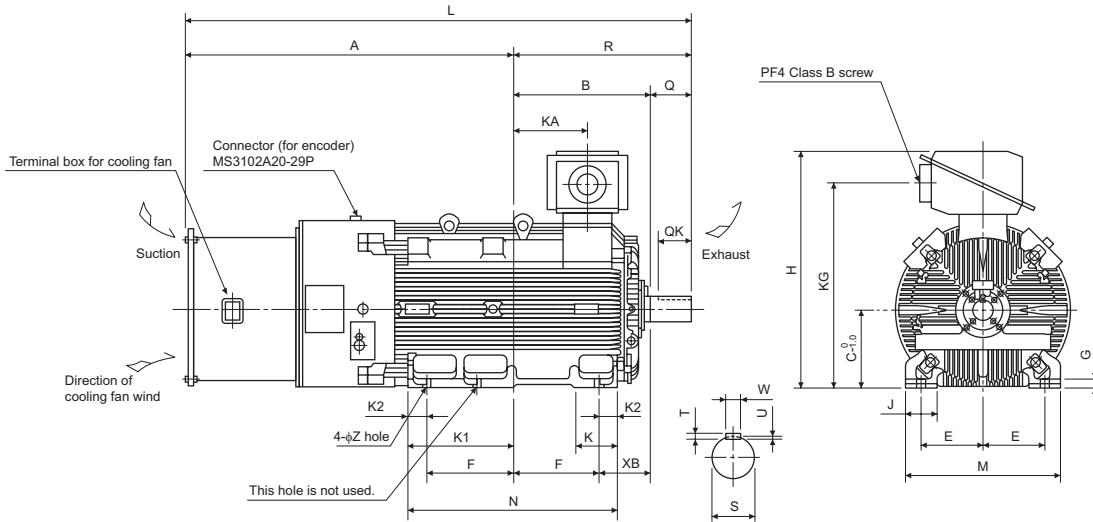

Dimensions table

(Unit: mm)

Output	Frame No.	Mass (kg)	Motor																	Shaft End Size								
			A	B	C	D	E	F	G	H	J	K	K1	K2	L	M	N	R	Z	XB	KA	KG	Q	QK	S	W	T	U
75	250MD	610	988.5	340.5	250	557	203	174.5	30	775	100	130	168	50	1471	486	449	482.5	24	168	157.5	635	140	110	φ75m6	20	12	7.5
90	250MD	660	988.5	340.5	250	557	203	174.5	30	775	100	130	168	50	1471	486	449	482.5	24	168	157.5	635	140	110	φ75m6	20	12	7.5
110	280MD	870	1049.5	397.5	280	607	228.5	209.5	30	845	110	130	181	40	1619	560	449	569.5	24	190	210.5	705	170	140	φ85m6	22	14	9
132	280MD	890	1049.5	397.5	280	607	228.5	209.5	30	845	110	130	181	40	1619	560	449	569.5	24	190	210.5	705	170	140	φ85m6	22	14	9
160	280MD	920	1049.5	397.5	280	607	228.5	209.5	30	845	110	130	181	40	1619	560	499	569.5	24	190	210.5	705	170	140	φ85m6	22	14	9
200	280L	1170	1210.5	416.5	280	652	228.5	228.5	30	885	110	160	160	75	1799	560	607	588.5	24	190	214.5	745	170	140	φ85m6	22	14	9
250	315H	1630	1343	565	315	717	254	355	35	965	130	175	428	80	2084	636	870	741	28	216	306	825	170	140	φ95m6	25	14	9

Note) The tolerance of the top and bottom of the center shaft height °C is ± 0.05 for the 250 frame and ± 0.10 for the 280 frame or more.

- Features
- Peripheral Devices
- Standard Specifications
- Outline Dimension Drawings
- Terminal Connection Diagram Terminal Specification Explanation
- Operation Panel
- Parameter List
- Explanations of Parameters
- Protective Functions
- Options
- Instructions
- Motor
- Compatibility
- Warranty
- Inquiry

Inverter-driven 400V class motor

When driving a 400V class motor by the inverter, surge voltages attributable to the wiring constants may occur at the motor terminals, deteriorating the insulation of the motor. In such a case, consider taking the following measures.

(1) Rectifying the motor insulation

1. Use a "400V class inverter driven insulation-enhanced motor".

Note: The four poles of the Mitsubishi standard motor (SF-JR, SB-JR) have the 400V class inverter driving insulation-enhanced feature.

2. For the dedicated motor such as the constant-torque motor and low-vibration motor, use the "inverter-driven, dedicated motor".

(2) Suppressing the surge voltage on the inverter side

Connect a filter on the secondary side of the inverter to suppress a surge voltage so that the terminal voltage of the motor is 850V or less. When driving by the Mitsubishi inverter, connect an optional surge voltage suppression filter (FR-ASF-H) for the 55K or less and an optional sine wave filter (MT-BSL, BSC) for the 75K or more on the inverter output side.

Application to special motors

Motor with brake

Use the motor with brake having independent power supply for the brake, connect the brake power supply to the inverter primary side power and make the inverter output off using the output stop terminal (MRS) when the brake is applied (motor stop). Rattle may be heard according to the type of the brake in the low speed region but it is not a fault.

Geared motor

The continuous operating rotation range of this motor changes depending on the lubrication system and maker. Especially in the case of oil lubrication, continuous operation in the low-speed range only can cause gear seizure. For fast operation at higher than 60Hz, please consult the motor maker.

Pole changing motor

As this motor differs in rated current from the standard motor, confirm the maximum current of the motor and select the inverter. Be sure to change the number of poles after the motor has stopped. If the number of poles is changed during rotation, the regenerative overvoltage protection circuit may be activated to cause an inverter alarm, coasting the motor to a stop.

Synchronous motor

This motor is not suitable for applications of large load variation or impact, where out-of-sync is likely to occur. Please contact us when using this motor because its starting current and rated current are greater than those of the standard motor and will not rotate stably at low speed.

Submersible motor

Since the motor rated current is larger than that of the standard motor, make selection of the inverter capacity carefully. In addition, the wiring distance between the motor and inverter may become longer, refer to page 87 to perform wiring with a cable thick enough. Leakage current may flow more than the land motor, take care when selecting the earth leakage current breaker.

Single phase motor

The single phase motor is not suitable for variable operation by the inverter.

For the capacitor starting system, the capacitor may be damaged due to harmonic current flowing to the capacitor. For the deviation phase starting system and repulsion starting system, not only output torque is not generated at low speed but it will result in starting coil burnout due to failure of centrifugal force switch inside. Replace with a three-phase motor for use.

Explosion-proof motor

To drive an explosion-proof type motor, an explosion-proof test of the motor and inverter together is necessary. The test is also necessary when driving an existing explosion-proof motor.

The inverter is a non-explosion proof structure, install it in a safety location.

Item	FR-A500(L)	FR-A700
Control method	V/F control Advanced magnetic flux vector control	V/F control Advanced magnetic flux vector control Real sensorless vector control Vector control (used with a plug-in option FR-A7AP/FR-A7AL)
Changed/cleared functions	User group 1 (16), user group 2 (16) <i>(Pr. 160, Pr. 173 to Pr. 175)</i>	User group (16) only Setting methods were partially changed <i>(Pr. 160, Pr. 172 to Pr. 173)</i>
	User initial value setting <i>(Pr. 199)</i>	User initial value setting <i>(Pr. 199)</i> was cleared Substitutable with the copy function of the operation panel (FR-DU07)
	Long wiring mode <i>(Pr. 240 setting 10, 11)</i>	Setting is not necessary <i>(Pr. 240 settings "10" and "11" were cleared)</i>
	Intelligent mode selection <i>(Pr. 60)</i>	Parameter number change <i>(Pr. 60 Energy saving control selection)</i> <i>(Pr. 292 Automatic acceleration/deceleration)</i>
	Program operation <i>(Pr. 200 to Pr. 231)</i>	Function was cleared
	PID action set point setting <i>(Pr. 133)</i>	Addition of "9999" to PID action set point <i>(Pr. 133)</i> setting (a value input from terminal 2 is a set point)
	Number of motor poles <i>(Pr. 81, Pr. 144)</i>	Setting the number of motor poles in Number of motor poles <i>(Pr. 81)</i> automatically changes the speed setting switchover <i>(Pr. 144)</i> setting.
	Performing parameter clear and all clear (H5A96, HAA99) with the FR-A7ND clears <i>Pr. 345 and Pr. 346</i> .	<i>Pr. 345 and Pr. 346</i> are not cleared.
Terminal block	Removable terminal block	Removable terminal block Upward compatibility (A500 terminal block mountable)
PU	FR-PU04, DU04	FR-PU07 FR-DU07 FR-PU04 (Some functions, such as parameter copy, are unavailable.) FR-DU04 unavailable
Plug-in options	Dedicated plug-in option (incompatible)	
	Computer link, relay output option FR-A5NR	Built into the inverter (RS-485 terminals, relay output 2 points)
Installation size	<ul style="list-style-type: none"> FR-A720-0.4K to 90K, FR-A740-0.4K to 7.5K, 18.5K to 55K, 110K, 160K are compatible in mounting dimensions For the FR-A740-11K, 15K, an optional intercompatibility attachment (FR-AAT) is necessary. Heatsink protrusion attachment is not compatible. Also, the panel cut dimension of 3.7K or less, 200V class 30K, 55K or more, 400V class 11K, 15K, 75K or more is not compatible. 	

Features

Peripheral Devices

Standard Specifications

Outline Dimension Drawings

Terminal Connection Diagram Terminal Specification Explanation

Operation Panel

Parameter List

Explanations of Parameters

Protective Functions

Options

Instructions

Motor

Compatibility

Warranty

Inquiry

Warranty

1. Gratis warranty period and coverage

[Gratis warranty period]

Note that an installation period of less than one year after installation in your company or your customer's premises or a period of less than 18 months (counted from the date of production) after shipment from our company, whichever is shorter, is selected.

[Coverage]

(1) Diagnosis of failure

As a general rule, diagnosis of failure is done on site by the customer.

However, Mitsubishi or Mitsubishi service network can perform this service for an agreed upon fee upon the customer's request.

There will be no charges if the cause of the breakdown is found to be the fault of Mitsubishi.

(2) Breakdown repairs

There will be a charge for breakdown repairs, exchange replacements and on site visits for the following four conditions, otherwise there will be a charge.

- 1) Breakdowns due to improper storage, handling, careless accident, software or hardware design by your company and your customers.
- 2) Breakdowns due to modifications of the product without the consent of the manufacturer.
- 3) Breakdowns resulting from using the product outside the specified specifications of the product.
- 4) Breakdowns that are outside the terms of warranty.

Since the above services are limited to Japan, diagnosis of failures, etc. are not performed abroad.

If you desire the after service abroad, please register with Mitsubishi. For details, consult us in advance.

2. Exclusion of opportunity loss from warranty liability

Regardless of the gratis warranty term, compensation to opportunity loss incurred to your company or your customers by failures of Mitsubishi products and compensation for damages to products other than Mitsubishi products and other services are not covered under warranty.

3. Repair period after production is discontinued

Mitsubishi shall accept product repairs for seven years after production of the product is discontinued.

4. Terms of delivery

In regard to the standard product, Mitsubishi shall deliver the standard product without application settings or adjustments to the customer and Mitsubishi is not liable for on site adjustment or test run of the product.

International FA center

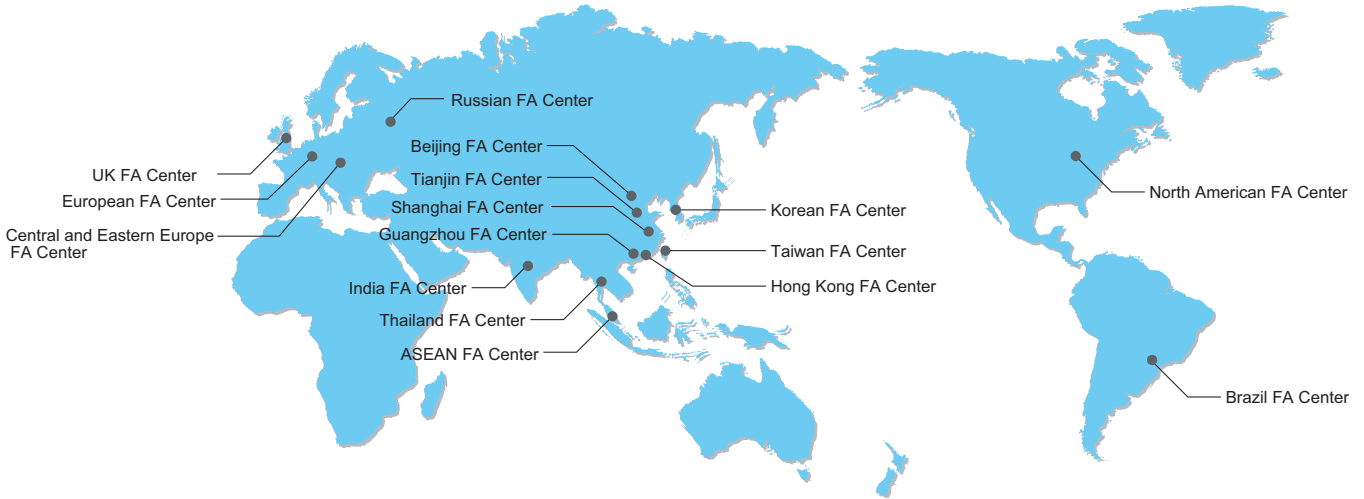

- North American FA Center**
 MITSUBISHI ELECTRIC AUTOMATION, INC.
 500 Corporate Woods Parkway, Vernon Hills, IL60061 U.S.A
 TEL. +1-847-478-2100 FAX. +1-847-478-0327
- Korean FA Center**
 MITSUBISHI ELECTRIC AUTOMATION KOREA CO., LTD.
 B1F,2F, 1480-6, Gayang-Dong, Gangseo-Gu, Seoul, 157-200, Korea
 TEL. +82-2-3660-9607 FAX. +82-2-3664-0475
- Taiwan FA Center**
 SETSUYO ENTERPRISE CO., LTD.
 6F No.105, Wu Kung 3rd RD, Wu-Ku Hsiang Taipei Hsien, 248, Taiwan
 TEL. +886-2-2299-2499 FAX. +886-2-2299-2509
- Beijing FA Center**
 MITSUBISHI ELECTRIC AUTOMATION (SHANGHAI) LTD. BEIJING OFFICE
 9F Office Tower 1, Henderson Center, 18 Jianguomennei Avenue, Dongcheng District, Beijing, China 100005
 TEL. +86-10-6518-8830 FAX. +86-10-6518-8030
- Russian FA Center**
 MITSUBISHI ELECTRIC EUROPE B.V.
 -Representative Office in St. Petersburg
 Sverdlovskaya Emb.,44, Bld Sch, BC "Benua";195027, St.Petersburg, Russia
 TEL. +7-812-633-3496 FAX. +7-812-633-3499
- Tianjin FA Center**
 MITSUBISHI ELECTRIC AUTOMATION (SHANGHAI) LTD. TIANJIN OFFICE
 B-2 801/802, Youyi Building, No.50 Youyi Road, Hexi District, Tianjin, China 300061
 TEL +86-22-2813-1015 FAX. +86-22-2813-1017
- Shanghai FA Center**
 MITSUBISHI ELECTRIC AUTOMATION (SHANGHAI) LTD.
 4/F Zhi Fu Plazz, No.80 Xin Chang Road, Shanghai, China 200003
 TEL. +86-21-6121-2460 FAX. +86-21-6121-2424
- Guangzhou FA Center**
 MITSUBISHI ELECTRIC AUTOMATION (SHANGHAI) LTD. GUANGZHOU OFFICE
 Rm.1609, North Tower, The Hub Center, No.1068, Xing Gang East Road, Haizhu District, Guangzhou, China 510335
 TEL. +86-20-8923-6713 FAX. +86-20-8923-6715
- Hong Kong FA Center**
 MITSUBISHI ELECTRIC AUTOMATION (Hong Kong) LTD.
 10th Floor, Manulife Tower, 169 Electric Road, North Point, Hong Kong
 TEL.+852-2887-8870 FAX. +852-2887-7984
- India FA Center**
 Mitsubishi Electric Asia Pvt. Ltd. Gurgaon Branch
 2nd Floor, DLF Building No.9B, DLF Cyber City Phase III, Gurgaon 122002, Haryana, India
 TEL. +91-124-4630300 FAX. +91-124-4630399
- Thailand FA Center**
 MITSUBISHI ELECTRIC AUTOMATION (THAILAND) CO., LTD.
 Bang-Chan Industrial Estate No.111, Soi Serithai 54, T.Kannayao, A.Kannayao, Bangkok 10230
 TEL. +66-2-906-3238 FAX. +66-2-906-3239
- ASEAN FA Center**
 MITSUBISHI ELECTRIC ASIA PTE, LTD.
 307 Alexandra Road #05-01/02, Mitsubishi Electric Building, Singapore 159943
 TEL. +65-6470-2480 FAX. +65-6476-7439
- European FA Center**
 MITSUBISHI ELECTRIC EUROPE B. V. GERMAN BRANCH
 Gothaer Strasse 8, D-40880 Ratingen, Germany
 TEL. +49-2102-486-0 FAX. +49-2102-486-1120
- UK FA Center**
 MITSUBISHI ELECTRIC EUROPE B. V. UK BRANCH
 Travellers Lane, Hatfield, Hertfordshire, AL10 8XB, UK.
 TEL. +44-1707-276100 FAX. +44-1707-278695
- Central and Eastern Europe FA Center**
 MITSUBISHI ELECTRIC EUROPE B.V. CZECH BRANCH
 Avenir Business Park, Radlicka 714/113a,158 00 Praha 5, Czech Republic
 TEL. +420-251-551-470 FAX. +420-251-551-471
- Brazil FA Center**
 MELCO-TEC Representacao Comercial e Assessoria Tecnica Ltda.
 Av. Paulista 1439, conj.74, Bela Vista CEP: 01311-200 Sao Paulo-SP-Brazil
 TEL. +55-11-3146-2202 FAX. +55-11-3146-2217

- Features
- Peripheral devices
- Standard Specifications
- Outline Dimension Drawings
- Terminal Connection Diagram Terminal Specification Explanation
- Operation Panel
- Parameter List
- Explanations of Parameters
- Protective Functions
- Options
- Instructions
- Motor
- Compatibility

Warranty

Inquiry

 **Safety Warning**

To ensure proper use of the products listed in this catalog,
please be sure to read the instruction manual prior to use.